

Series AS2



AVENTICS™ Series AS2



Air preparation unit, 2-part, Series AS2-ACD

- G 1/4 G 3/8
- filter porosity 5 μm
- lockable
- for padlocks
- with pressure gauge
- suitable for ATEX

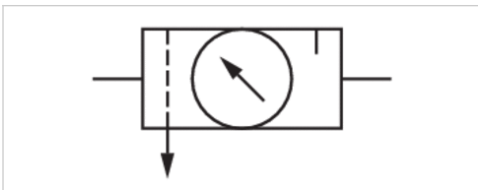

Version	2-part, Can be assembled into blocks
Parts	Filter pressure regulator, Lubricator
Mounting orientation	vertical
Certificates	suitable for ATEX
Working pressure min./max.	1.5 ... 16 bar
Ambient temperature min./max.	-10 ... 50 °C
Medium temperature min./max.	-10 ... 50 °C
Medium	Compressed air Neutral gases
Regulator type	Diaphragm-type pressure regulator
Regulator function	with relieving air exhaust
Adjustment range min./max.	0.5 ... 8 bar
Pressure supply	single
Filter reservoir volume	28 cm ³
Filter element	exchangeable
Lubricator reservoir volume	40 cm ³
Type of filling	Manual oil filling Semi-automatic oil filling during operation
Weight	See table below

Technical data

Part No.	Port	filter porosity	Flow	Condensate drain
			Qn	
R412006298	G 1/4	5 μm	1800 l/min	semi-automatic, open without pressure
R412006304	G 1/4	5 μm	1800 l/min	semi-automatic, open without pressure
R412006299	G 1/4	5 μm	1800 l/min	fully automatic, open without pressure
R412006300	G 1/4	5 μm	1800 l/min	fully automatic, closed without pressure
R412006307	G 3/8	5 μm	2000 l/min	semi-automatic, open without pressure
R412006308	G 3/8	5 μm	2000 l/min	fully automatic, open without pressure
R412006309	G 3/8	5 μm	2000 l/min	fully automatic, closed without pressure

Part No.	Pressure gauge	Reservoir	Protective guard	Weight	Fig.
R412006298	with pressure gauge	Polycarbonate	Polyamide	0.633 kg	Fig. 1
R412006304	with pressure gauge	Die cast zinc	-	0.633 kg	Fig. 1
R412006299	with pressure gauge	Polycarbonate	Polyamide	0.676 kg	Fig. 1
R412006300	with pressure gauge	Polycarbonate	Polyamide	0.676 kg	Fig. 1
R412006307	with pressure gauge	Polycarbonate	Polyamide	0.633 kg	Fig. 2
R412006308	with pressure gauge	Polycarbonate	Polyamide	0.676 kg	Fig. 2
R412006309	with pressure gauge	Polycarbonate	Polyamide	0.676 kg	Fig. 2

Nominal flow Q_n with secondary pressure $p_2 = 6 \text{ bar}$ at $\Delta p = 1 \text{ bar}$

Suitable for use in Ex zones 1, 2, 21, 22.

Technical information

The pressure dew point must be at least 15 °C under ambient and medium temperature and may not exceed 3 °C .

Note: Polycarbonate reservoirs are susceptible to solvents, supplementary information can be found at "Customer information".

Suitable for use in Ex zones 1, 2, 21, 22.

A change in the flow direction (from air supply on the left to air supply on the right) occurs by rotating installation by 180° about the vertical axis. Please see the operating instructions for further details.

Also suitable for separation of fluid oil or water due to the design.

Max. achievable compressed air class acc. to ISO 8573-1:2010 6 : 7 : -

Technical information

Material	
Housing	Polyamide
Front plate	Acrylonitrile butadiene styrene
Seals	Acrylonitrile butadiene rubber
Threaded bushing	Die cast zinc
Reservoir	Polycarbonate Die cast zinc
Protective guard	Polyamide
Filter insert	Polyethylene

Dimensions

Dimensions in mm, Fig. 1

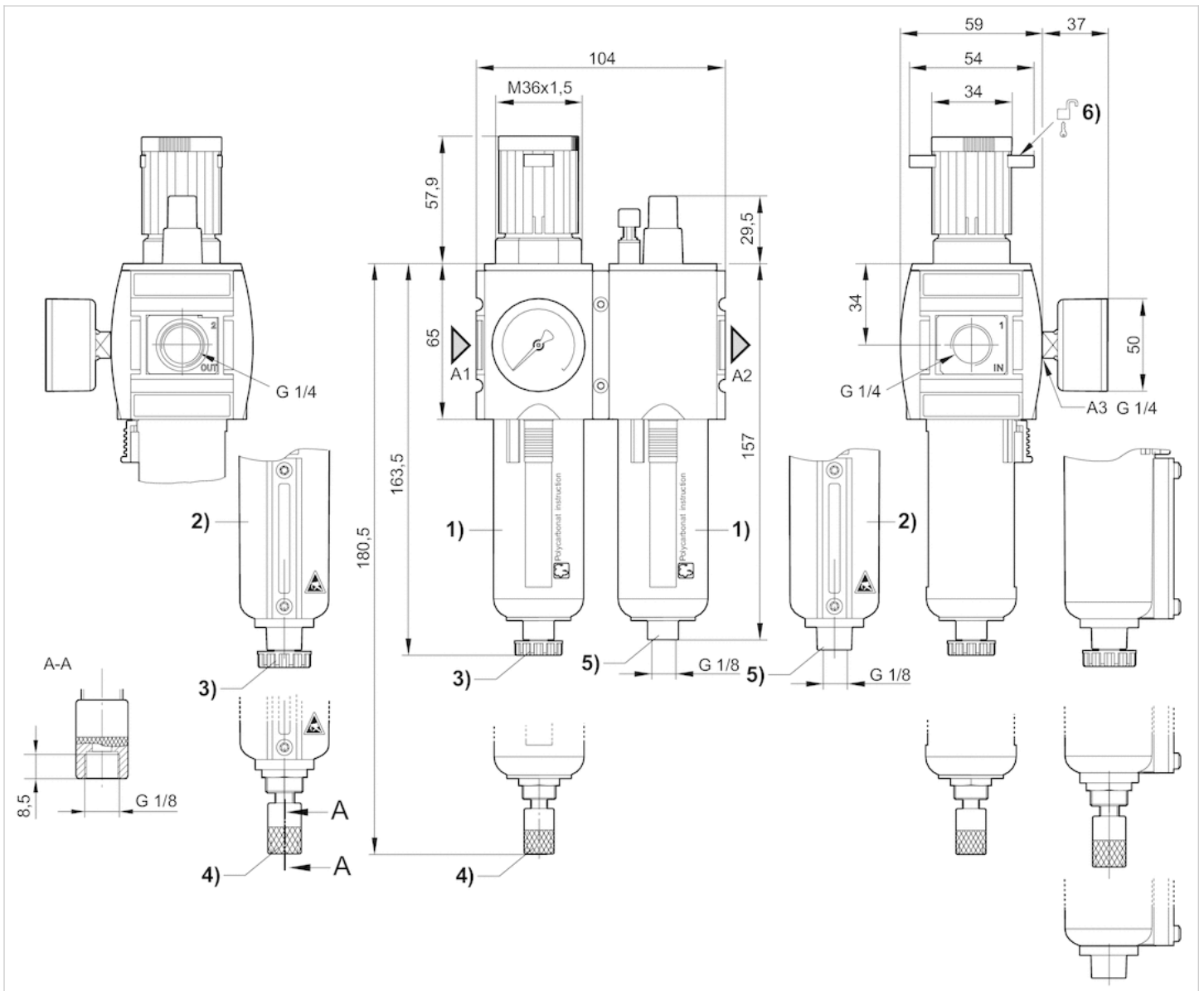

A1 = input

A2 = output

A3 = pressure gauge connection

A7 = condensate drain

1) Plastic reservoir and protective guard with window

2) Metal reservoir with level indicator

3) Semi-automatic condensate drain

4) Fully automatic condensate drain

5) Port for semi-automatic oil filling

6) Mounting option for padlocks, max. shackle \varnothing 8

Dimensions in mm, Fig. 2

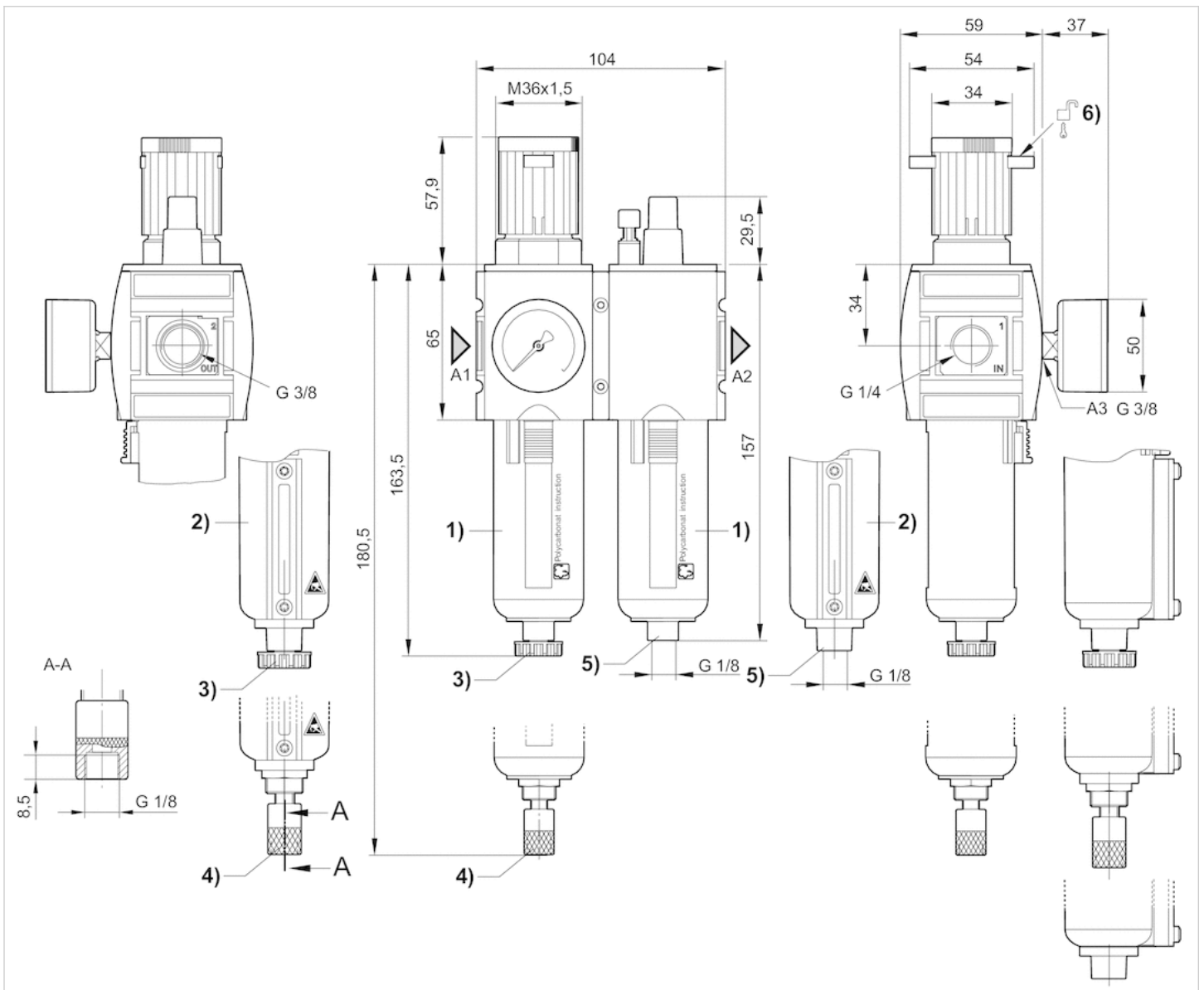

- A1 = input
- A2 = output
- A3 = pressure gauge connection
- A7 = condensate drain
- 1) Plastic reservoir and protective guard with window
- 2) Metal reservoir with level indicator
- 3) Semi-automatic condensate drain
- 4) Fully automatic condensate drain
- 5) Port for semi-automatic oil filling
- 6) Mounting option for padlocks, max. shackle Ø 8

Diagrams

Lubricator activation margin

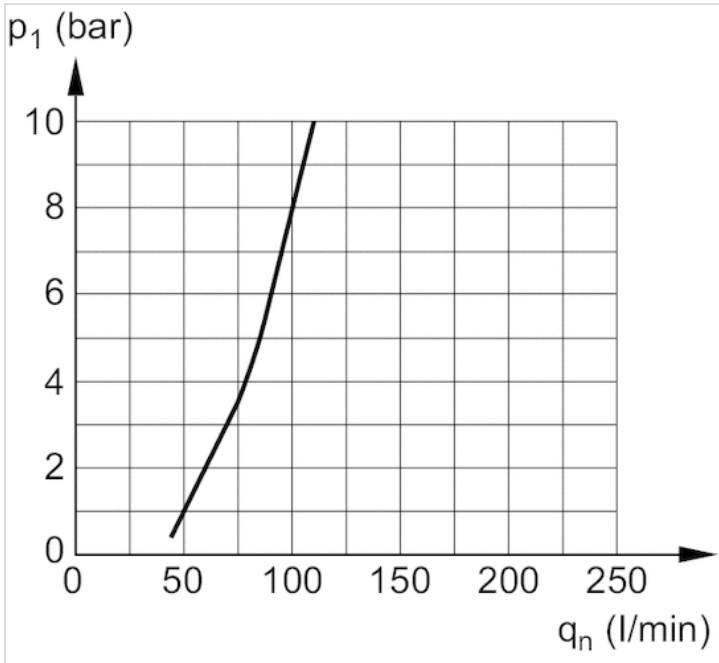

p1 = working pressure
qn = nominal flow

Flow rate characteristic (p2: 0,5 - 8 bar)

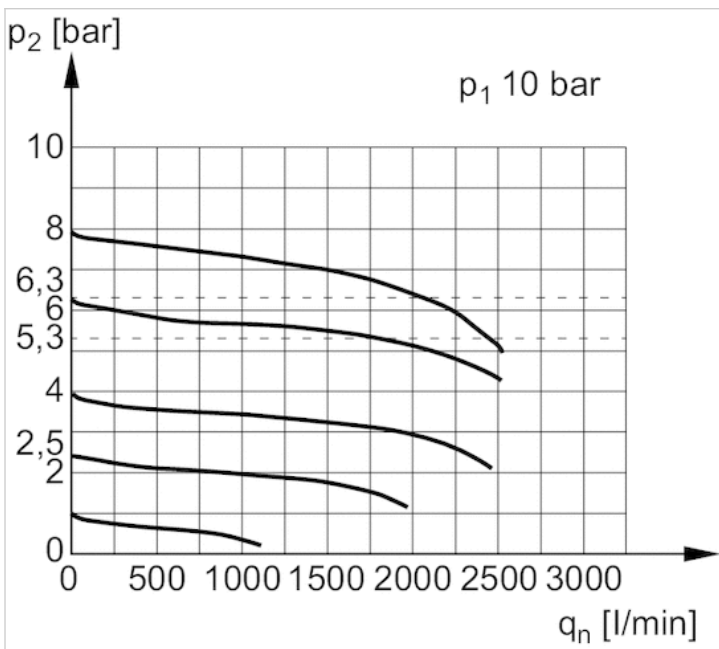

p1 = Working pressure
p2 = Secondary pressure
qn = Nominal flow

Accessories overview

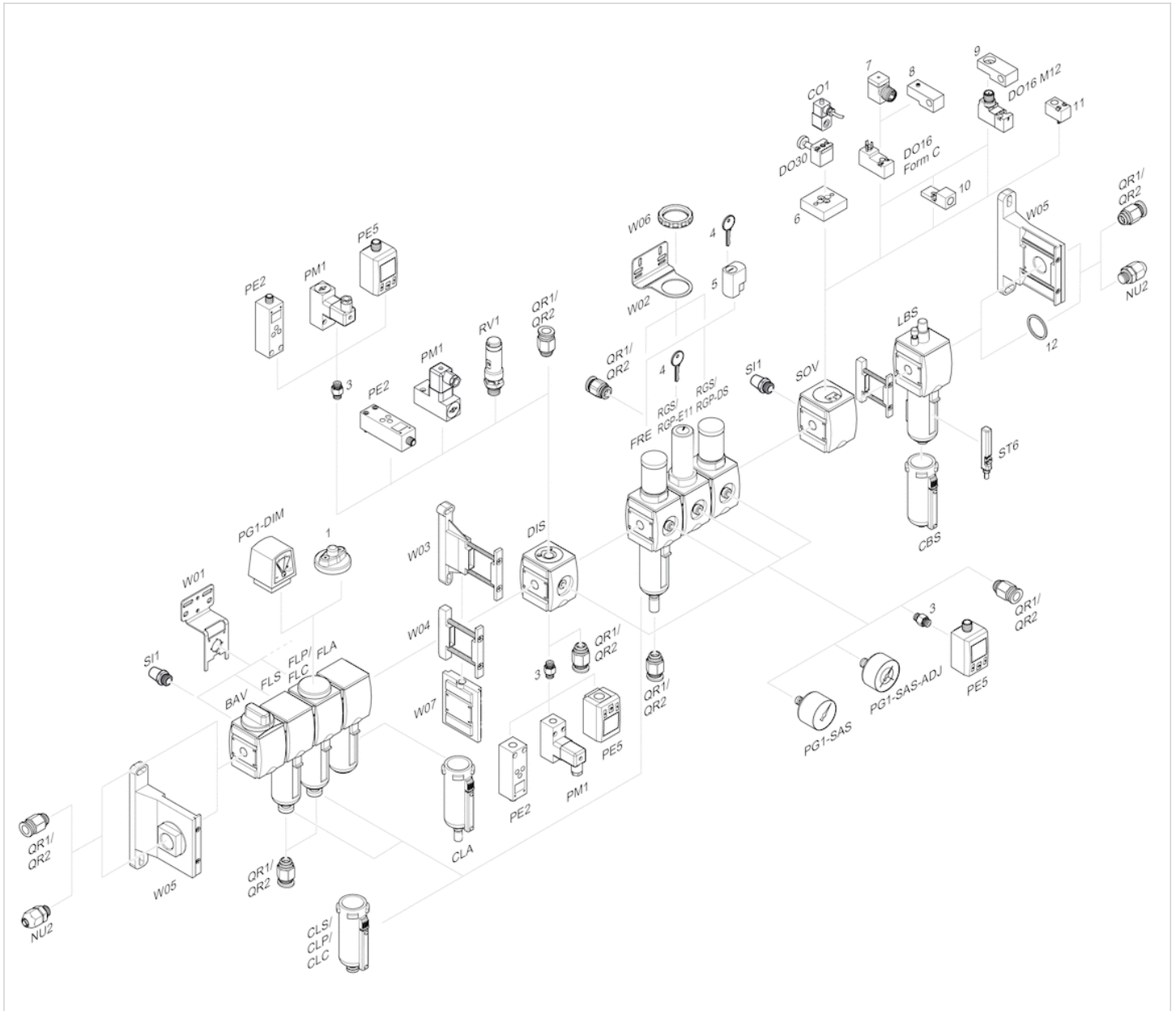

- 1 = contamination display
- 3 = Double nipple
- 4 = Key for E11 locking
- 5 = mortise lock
- 6 = Transition plate DO30
- 7 = Adapter, Series CON-VP
- 8 = Mounting aid DO16, form C
- 9 = Mounting aid DO16, M12
- 10 = Adapter for external pilot air
- 11 = Adapter pneumatic operation
- 12 = Sealing ring

Air preparation unit, 2-part, Series AS2-ACC

- G 1/4 G 3/8
- filter porosity 5 µm
- lockable
- for padlocks
- with pressure gauge
- suitable for ATEX



Version	2-part, Can be assembled into blocks
Parts	Shut-off valve, Filter pressure regulator, Pressure gauge, Silencer, Mountings
Mounting orientation	vertical
Working pressure min./max.	1.5 ... 16 bar
Ambient temperature min./max.	-10 ... 50 °C
Medium temperature min./max.	-10 ... 50 °C
Medium	Compressed air Neutral gases
Regulator type	Diaphragm-type pressure regulator
Regulator function	with relieving air exhaust
Adjustment range min./max.	0.5 ... 8 bar
Pressure supply	single
Filter reservoir volume	28 cm ³
Filter element	exchangeable
Weight	See table below

Technical data

Part No.	Port	filter porosity	Condensate drain	Pressure gauge
R412027667	G 1/4	5 µm	semi-automatic, open without pressure	with pressure gauge
R412027669	G 1/4	5 µm	fully automatic, open without pressure	with pressure gauge
R412027670	G 3/8	5 µm	semi-automatic, open without pressure	with pressure gauge

Part No.	Weight	Fig.
R412027667	1.25 kg	Fig. 1
R412027669	1.3 kg	Fig. 2
R412027670	1.3 kg	Fig. 3

Technical information

The pressure dew point must be at least 15 °C under ambient and medium temperature and may not exceed 3 °C .

Note: Polycarbonate reservoirs are susceptible to solvents, supplementary information can be found at "Customer information".

Suitable for use in Ex zones 1, 2, 21, 22.

A change in the flow direction (from air supply on the left to air supply on the right) occurs by rotating installation by 180° about the vertical axis. Please see the operating instructions for further details.

Also suitable for separation of fluid oil or water due to the design.

Max. achievable compressed air class acc. to ISO 8573-1:2010 6 : 7 : -

Technical information

Material	
Housing	Polyamide
Front plate	Acrylonitrile butadiene styrene
Seals	Acrylonitrile butadiene rubber
Threaded bushing	Die cast zinc
Reservoir	Polycarbonate
Protective guard	Polyamide
Filter insert	Polyethylene

Dimensions

Dimensions in mm, Fig. 1

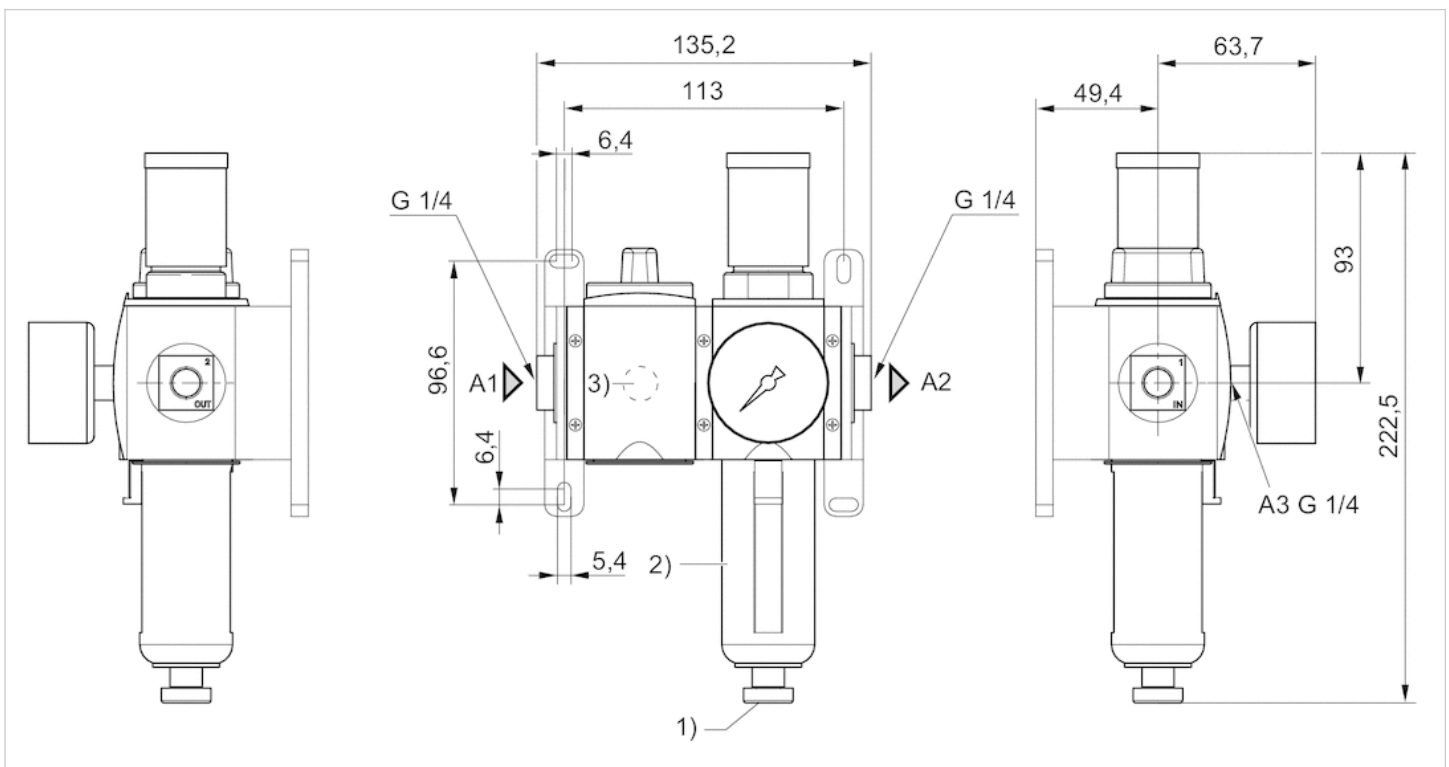

- A1 = input
- A2 = output
- A3 = pressure gauge connection
- 1) Semi-automatic condensate drain
- 2) Plastic reservoir and protective guard with window
- 3) Silencer

Dimensions in mm, Fig. 2

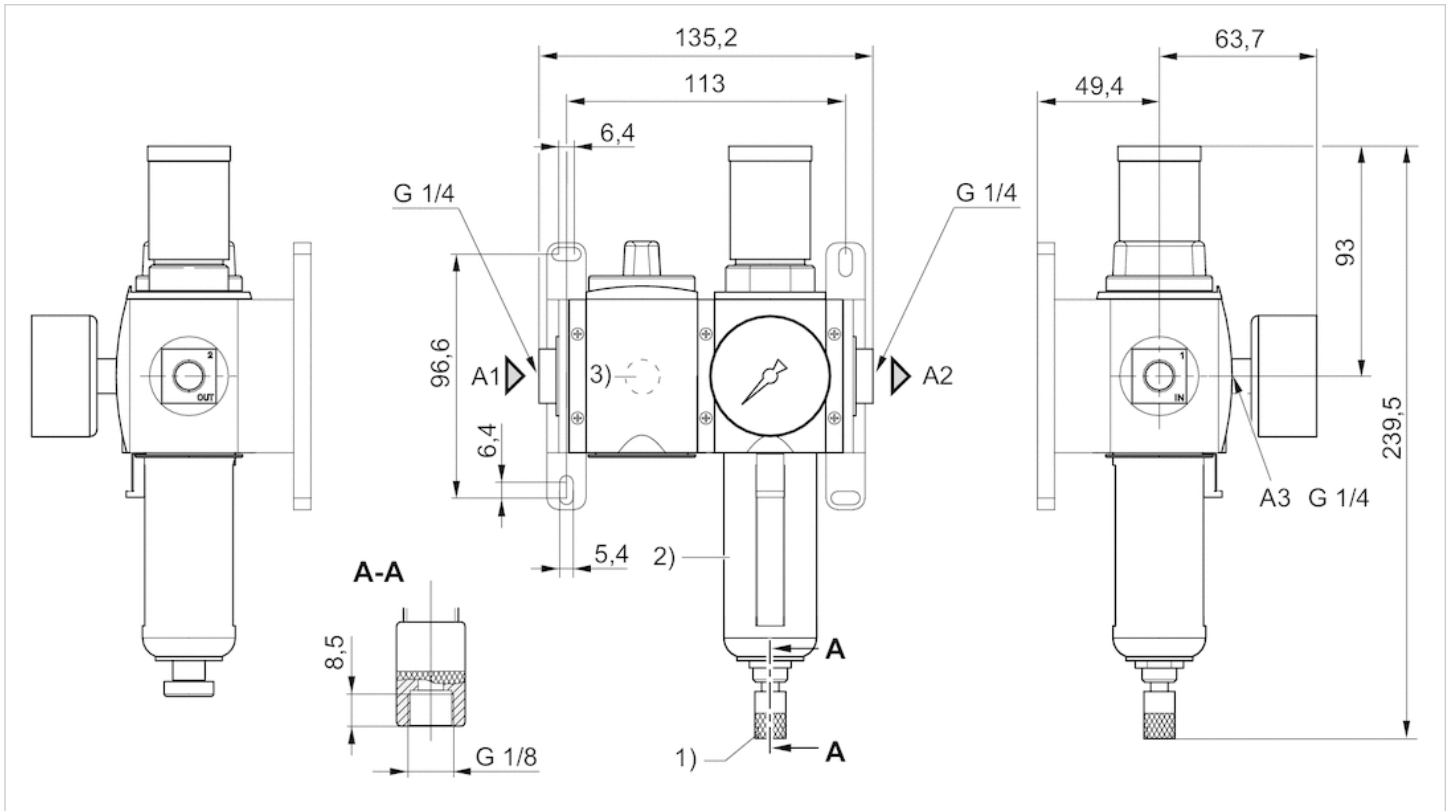

- A1 = input
- A2 = output
- A3 = pressure gauge connection
- A7 = condensate drain
- 1) Fully automatic condensate drain
- 2) Plastic reservoir and protective guard with window
- 3) Silencer

Dimensions in mm, Fig. 3

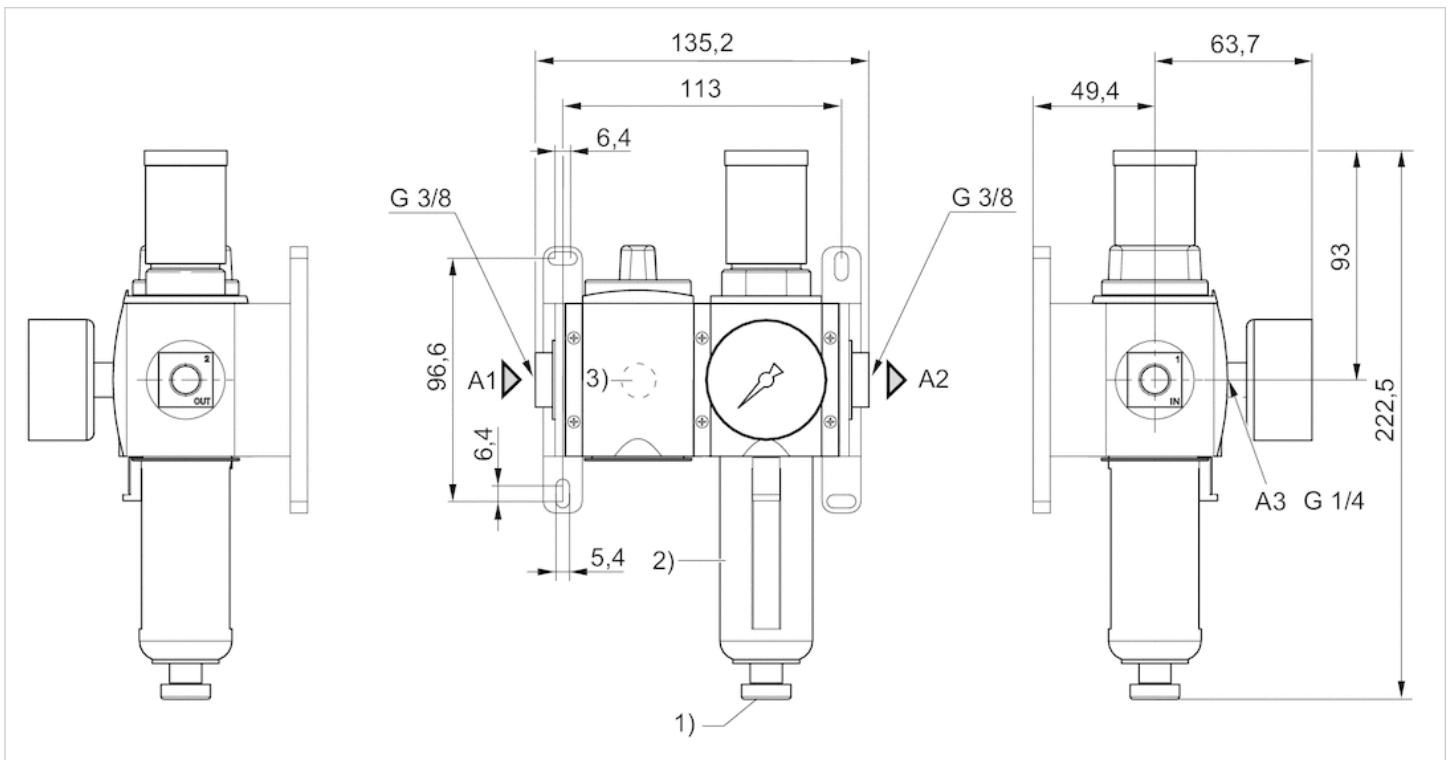

- A1 = input
- A2 = output
- A3 = pressure gauge connection
- 1) Semi-automatic condensate drain
- 2) Plastic reservoir and protective guard with window
- 3) Silencer

Circuit diagram

Block diagram

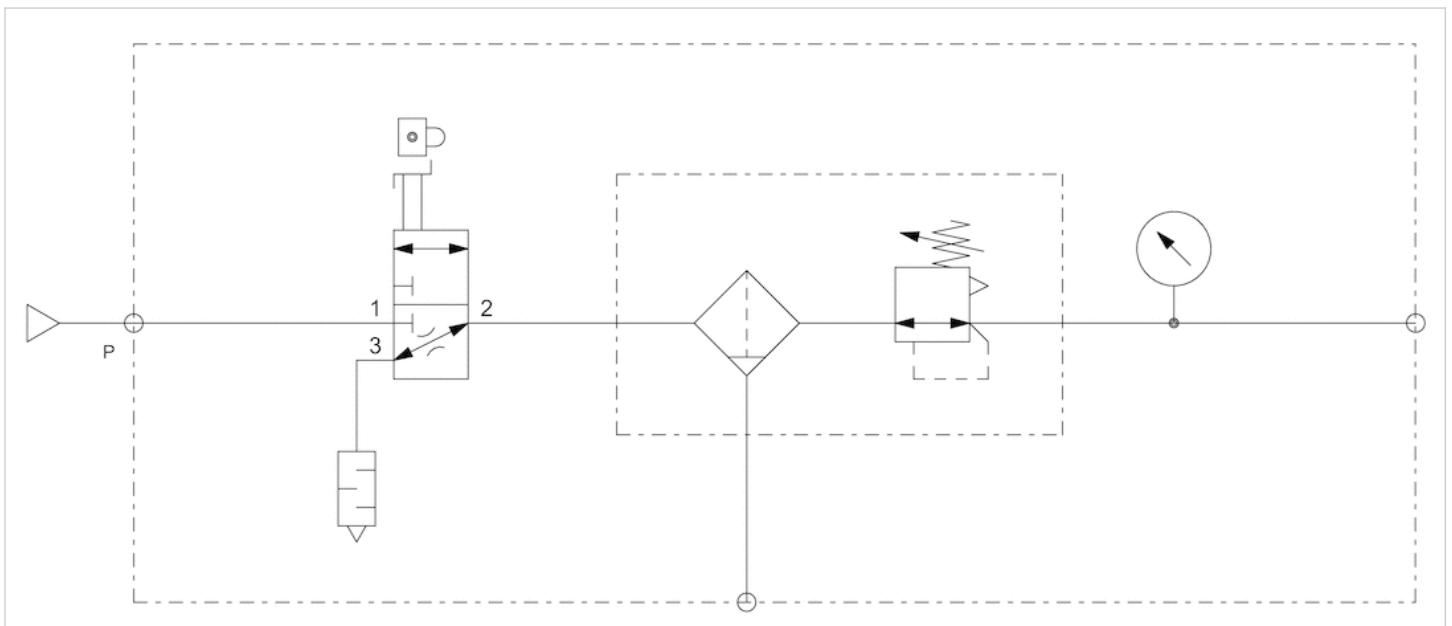

Accessories overview

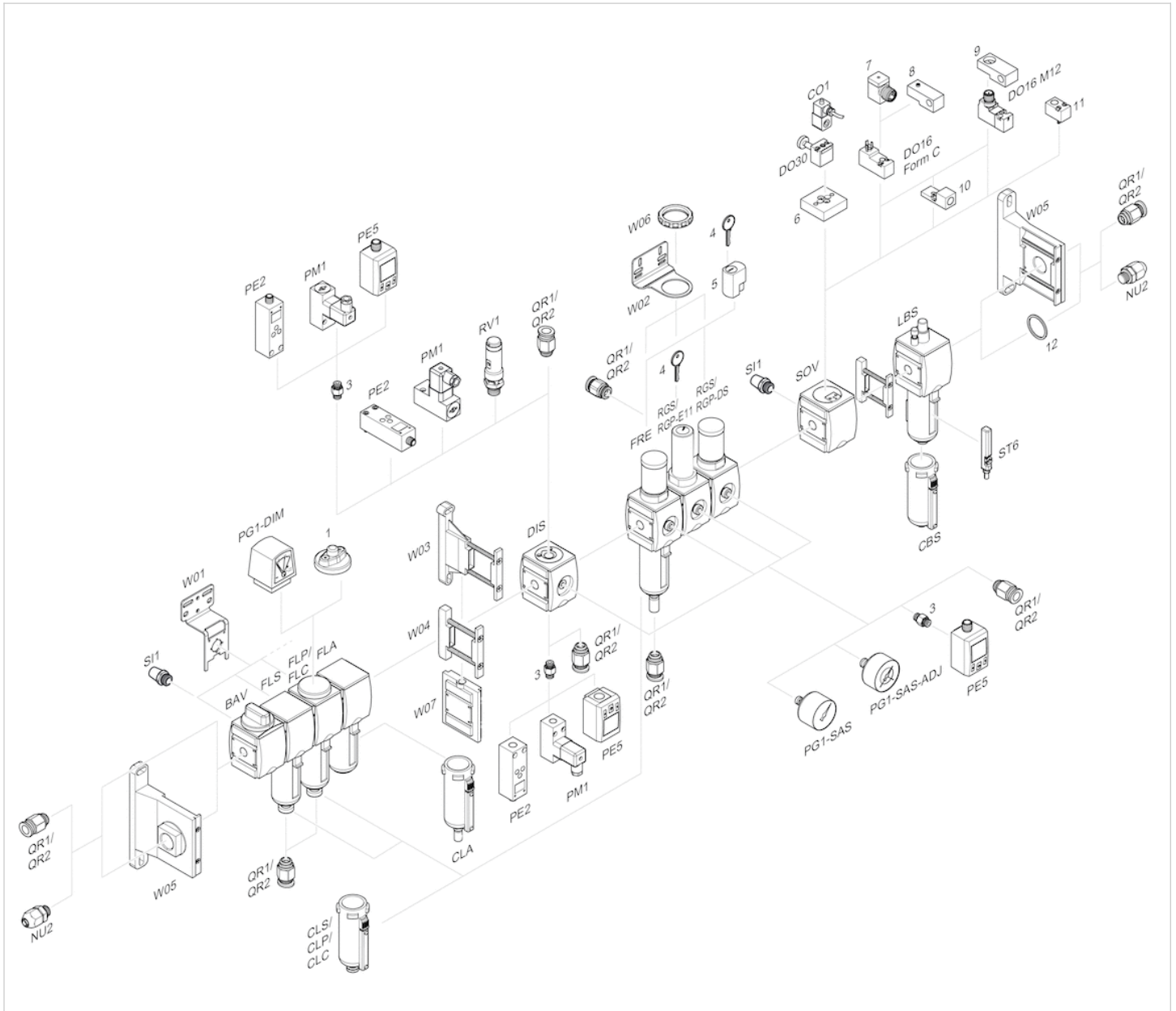

- 1 = contamination display
- 3 = Double nipple
- 4 = Key for E11 locking
- 5 = mortise lock
- 6 = Transition plate DO30
- 7 = Adapter, Series CON-VP
- 8 = Mounting aid DO16, form C
- 9 = Mounting aid DO16, M12
- 10 = Adapter for external pilot air
- 11 = Adapter pneumatic operation
- 12 = Sealing ring

Air preparation unit, 2-part, Series AS2-ACC

- filter porosity 5 µm
- lockable
- for padlocks
- with pressure gauge
- suitable for ATEX



Version	2-part, Can be assembled into blocks
Parts	Shut-off valve, Filter pressure regulator, Pressure gauge, Silencer, Mountings
Mounting orientation	vertical
Working pressure min./max.	1.5 ... 16 bar
Ambient temperature min./max.	-10 ... 50 °C
Medium temperature min./max.	-10 ... 50 °C
Medium	Compressed air Neutral gases
Regulator type	Diaphragm-type pressure regulator with relieving air exhaust
Regulator function	
Adjustment range min./max.	0.5 ... 8 bar
Pressure supply	single
Filter reservoir volume	28 cm ³
Filter element	exchangeable
Condensate drain	semi-automatic, open without pressure
Weight	0.841 kg

Technical data

Part No.	filter porosity	Condensate drain	Pressure gauge
R412027668	5 µm	semi-automatic, open without pressure	with pressure gauge

Technical information

The pressure dew point must be at least 15 °C under ambient and medium temperature and may not exceed 3 °C .

Note: Polycarbonate reservoirs are susceptible to solvents, supplementary information can be found at "Customer information".

Suitable for use in Ex zones 1, 2, 21, 22.

A change in the flow direction (from air supply on the left to air supply on the right) occurs by rotating installation by 180° about the vertical axis. Please see the operating instructions for further details.

Also suitable for separation of fluid oil or water due to the design.

Max. achievable compressed air class acc. to ISO 8573-1:2010 6 : 7 : -

Technical information

Material	
Housing	Polyamide
Front plate	Acrylonitrile butadiene styrene
Seals	Acrylonitrile butadiene rubber
Threaded bushing	Die cast zinc

Material	
Reservoir	Polycarbonate
Protective guard	Polyamide
Filter insert	Polyethylene

Dimensions

Dimensions in mm

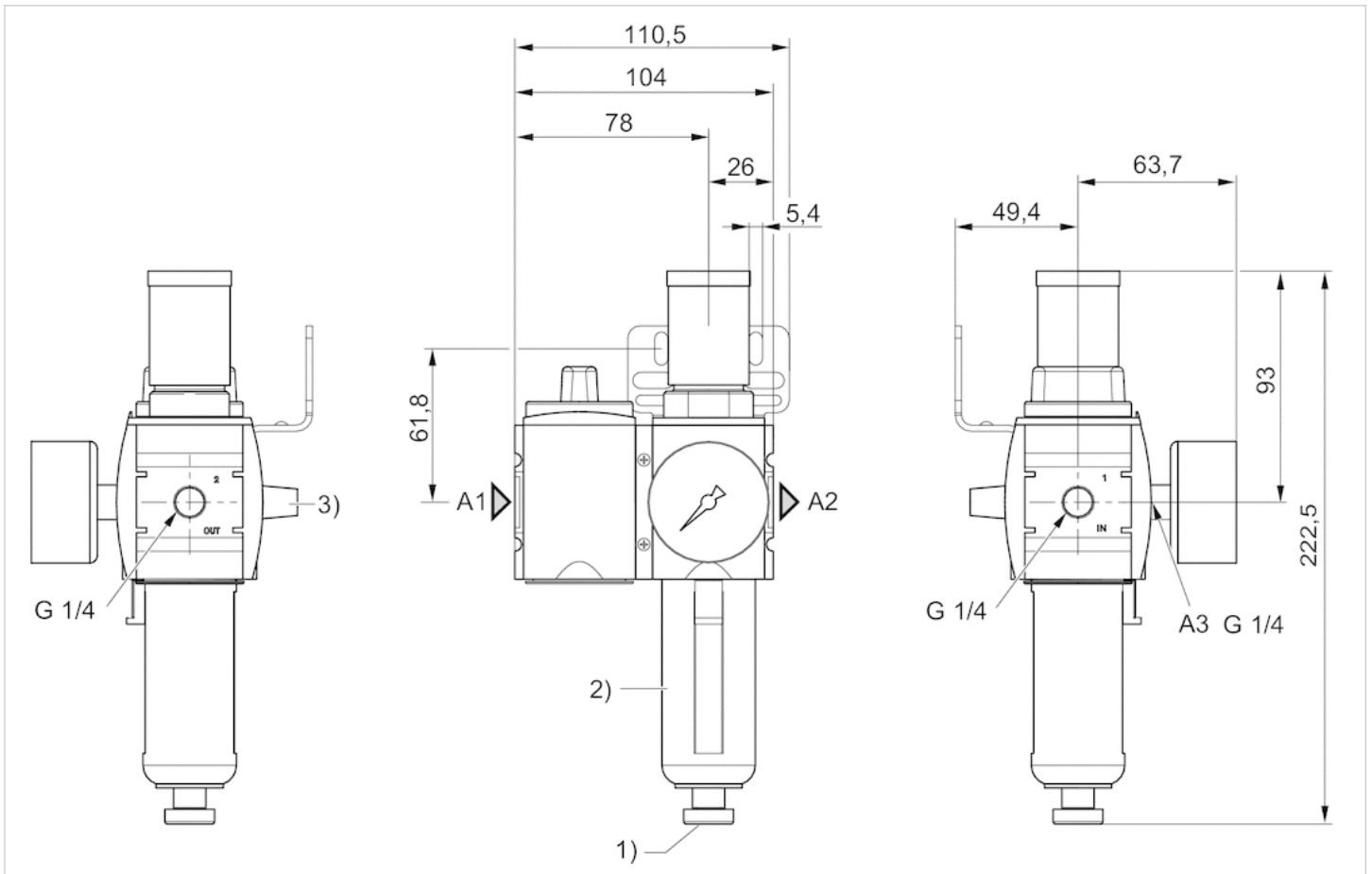

A1 = input

A2 = output

A3 = pressure gauge connection

1) semi-automatic condensate drain

2) Plastic reservoir and protective guard with window

3) Silencer

Circuit diagram

Block diagram

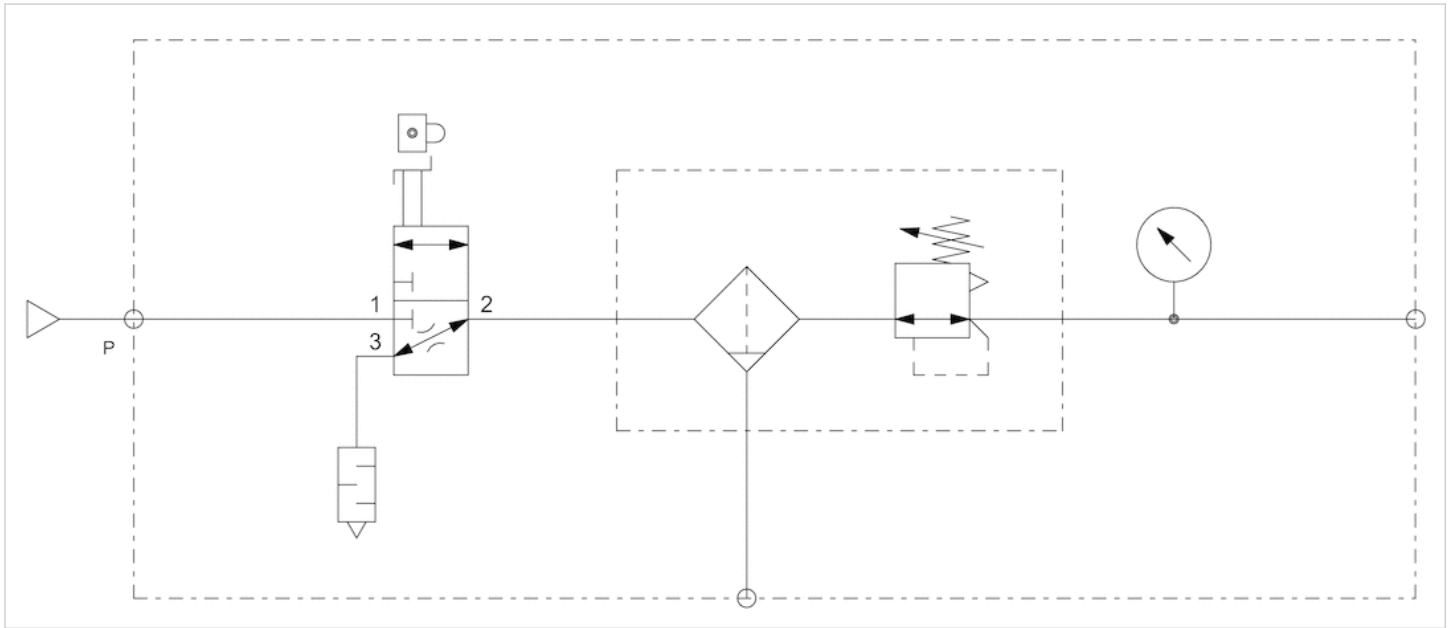

Accessories overview

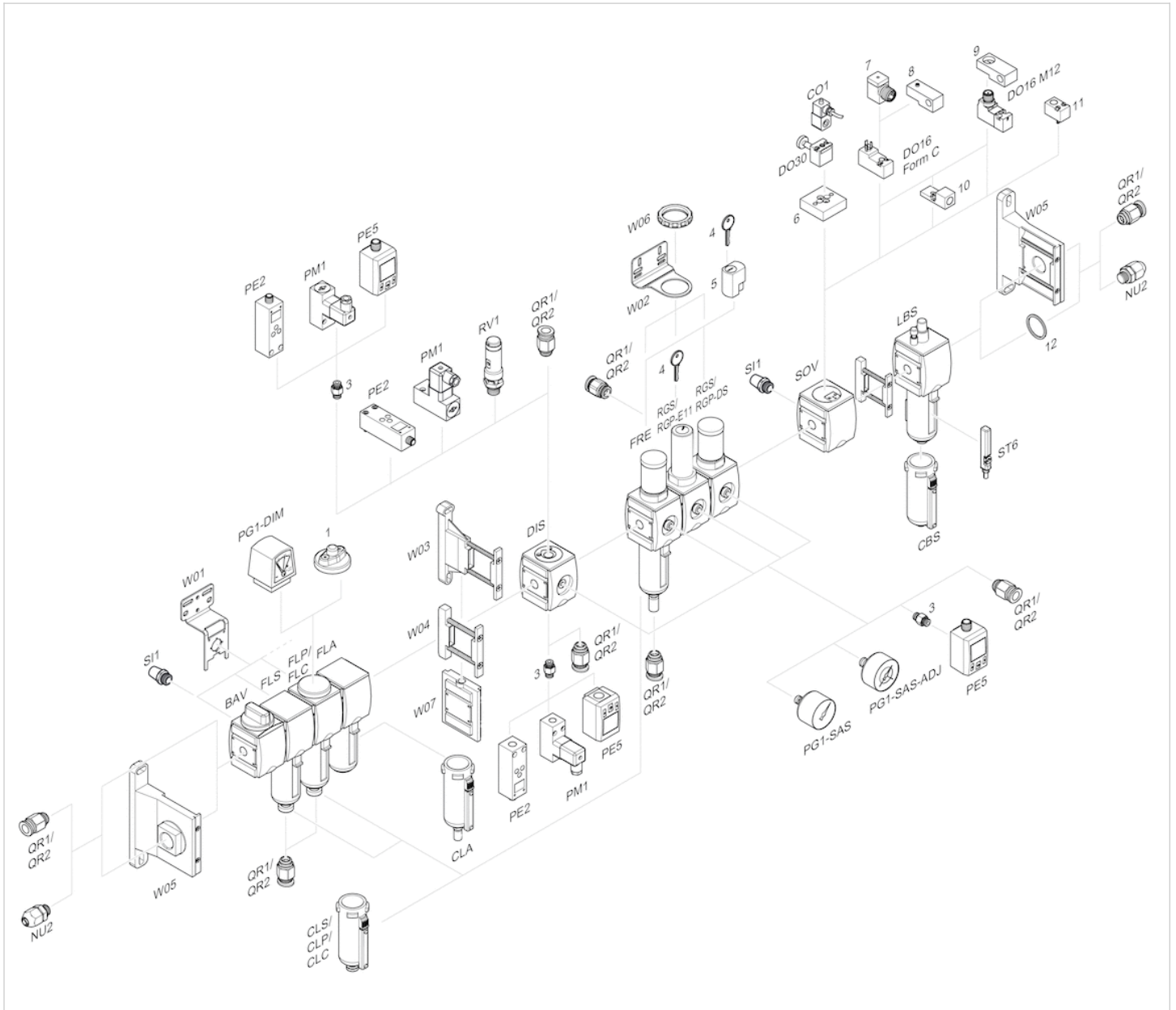

- 1 = contamination display
- 3 = Double nipple
- 4 = Key for E11 locking
- 5 = mortise lock
- 6 = Transition plate DO30
- 7 = Adapter, Series CON-VP
- 8 = Mounting aid DO16, form C
- 9 = Mounting aid DO16, M12
- 10 = Adapter for external pilot air
- 11 = Adapter pneumatic operation
- 12 = Sealing ring

Pressure regulator, Series AS2-RGS





- G 1/4 G 3/8
- Qn = 2200-2700 l/min
- Standard pressure regulator
- Activation Mechanical
- lockable
- for padlocks
- suitable for ATEX



Parts	Pressure regulator
Mounting orientation	Any
Certificates	suitable for ATEX
Working pressure min./max.	See table below
Ambient temperature min./max.	-10 ... 50 °C
Medium temperature min./max.	-10 ... 50 °C
Medium	Compressed air Neutral gases
Regulator type	Diaphragm-type pressure regulator Can be assembled into blocks
Regulator function	with relieving air exhaust
Adjustment range min./max.	See table below
Lock type	for padlocks
Pressure supply	single
Activation	Mechanical
Weight	See table below

Technical data

Part No.			Port	Flow	Working pressure min./max.	Adjustment range min./max.
				Qn		
R412006101			G 1/4	2200 l/min	0.1 ... 16 bar	0.1 ... 1 bar
R412006103			G 1/4	2200 l/min	0.1 ... 16 bar	0.1 ... 2 bar
R412006105			G 1/4	2200 l/min	0.2 ... 16 bar	0.2 ... 4 bar
R412006107			G 1/4	2200 l/min	0.5 ... 16 bar	0.5 ... 8 bar
R412006109			G 1/4	2200 l/min	0.5 ... 16 bar	0.5 ... 10 bar
R412006111			G 1/4	2200 l/min	0.5 ... 16 bar	0.5 ... 16 bar
R412006100		—	G 1/4	2200 l/min	0.1 ... 16 bar	0.1 ... 1 bar
R412006102		—	G 1/4	2200 l/min	0.1 ... 16 bar	0.1 ... 2 bar
R412006104		—	G 1/4	2200 l/min	0.2 ... 16 bar	0.2 ... 4 bar
R412006106		—	G 1/4	2200 l/min	0.5 ... 16 bar	0.5 ... 8 bar
R412006108		—	G 1/4	2200 l/min	0.5 ... 16 bar	0.5 ... 10 bar
R412006110		—	G 1/4	2200 l/min	0.5 ... 16 bar	0.5 ... 16 bar
R412006113			G 3/8	2700 l/min	0.1 ... 16 bar	0.1 ... 1 bar
R412006115			G 3/8	2700 l/min	0.1 ... 16 bar	0.1 ... 2 bar
R412006117			G 3/8	2700 l/min	0.2 ... 16 bar	0.2 ... 4 bar
R412006119			G 3/8	2700 l/min	0.5 ... 16 bar	0.5 ... 8 bar
R412006121			G 3/8	2700 l/min	0.5 ... 16 bar	0.5 ... 10 bar
R412006123			G 3/8	2700 l/min	0.5 ... 16 bar	0.5 ... 16 bar
R412006112		—	G 3/8	2700 l/min	0.1 ... 16 bar	0.1 ... 1 bar
R412006114		—	G 3/8	2700 l/min	0.1 ... 16 bar	0.1 ... 2 bar

Part No.			Port	Flow	Working pressure min./max.	Adjustment range min./max.
				Qn		
R412006116		—	G 3/8	2700 l/min	0.2 ... 16 bar	0.2 ... 4 bar
R412006118		—	G 3/8	2700 l/min	0.5 ... 16 bar	0.5 ... 8 bar
R412006120		—	G 3/8	2700 l/min	0.5 ... 16 bar	0.5 ... 10 bar
R412006122		—	G 3/8	2700 l/min	0.5 ... 16 bar	0.5 ... 16 bar
R414012351		—	G 1/4	2200 l/min	0.5 ... 16 bar	0.5 ... 8 bar

Part No.	Pressure gauge	Weight	Fig.	
R412006101	with pressure gauge	0.32 kg	Fig. 1	1)
R412006103	with pressure gauge	0.32 kg	Fig. 1	1)
R412006105	with pressure gauge	0.32 kg	Fig. 1	1)
R412006107	with pressure gauge	0.32 kg	Fig. 1	1)
R412006109	with pressure gauge	0.32 kg	Fig. 1	1)
R412006111	with pressure gauge	0.32 kg	Fig. 1	1)
R412006100	-	0.248 kg	Fig. 1	2)
R412006102	-	0.248 kg	Fig. 1	2)
R412006104	-	0.248 kg	Fig. 1	2)
R412006106	-	0.248 kg	Fig. 1	2)
R412006108	-	0.248 kg	Fig. 1	2)
R412006110	-	0.248 kg	Fig. 1	2)
R412006113	with pressure gauge	0.32 kg	Fig. 2	1)
R412006115	with pressure gauge	0.32 kg	Fig. 2	1)
R412006117	with pressure gauge	0.32 kg	Fig. 2	1)
R412006119	with pressure gauge	0.32 kg	Fig. 2	1)
R412006121	with pressure gauge	0.32 kg	Fig. 2	1)
R412006123	with pressure gauge	0.32 kg	Fig. 2	1)
R412006112	-	0.248 kg	Fig. 2	2)
R412006114	-	0.248 kg	Fig. 2	2)
R412006116	-	0.248 kg	Fig. 2	2)
R412006118	-	0.248 kg	Fig. 2	2)
R412006120	-	0.248 kg	Fig. 2	2)
R412006122	-	0.248 kg	Fig. 2	2)
R414012351	-	0.332 kg	Fig. 1	3)

Nominal flow Qn with secondary pressure p2 = 6 bar at $\Delta p = 1$ bar

- 1) Pressure gauge enclosed separately, Suitable for use in Ex zones 1, 2, 21, 22.
- 2) Order pressure gauge separately, Suitable for use in Ex zones 1, 2, 21, 22.
- 3) Order pressure gauge separately, Suitable for use in Ex zones 1, 2, 21, 22., Safe rear exhaust in case of drop (removal) of pilot pressure

Technical information

The pressure dew point must be at least 15 °C under ambient and medium temperature and may not exceed 3 °C .

The rear pressure gauge connection on the pressure regulator is closed with a blanking plug, the front connection is open. Depending on the customer application, a second blanking plug may be necessary. Please order separately (see accessories).

Suitable for use in Ex zones 1, 2, 21, 22.

A change in the flow direction (from air supply on the left to air supply on the right) occurs by rotating installation by 180° about the vertical axis. Please see the operating instructions for further details.

Relieving exhaust (≤ 0.3 bar over set pressure).

With rear exhaust (> 3 bar).

Technical information

Material	
Housing	Polyamide
Front plate	Acrylonitrile butadiene styrene
Seals	Acrylonitrile butadiene rubber
Threaded bushing	Die cast zinc

Dimensions

Dimensions in mm, Fig. 1

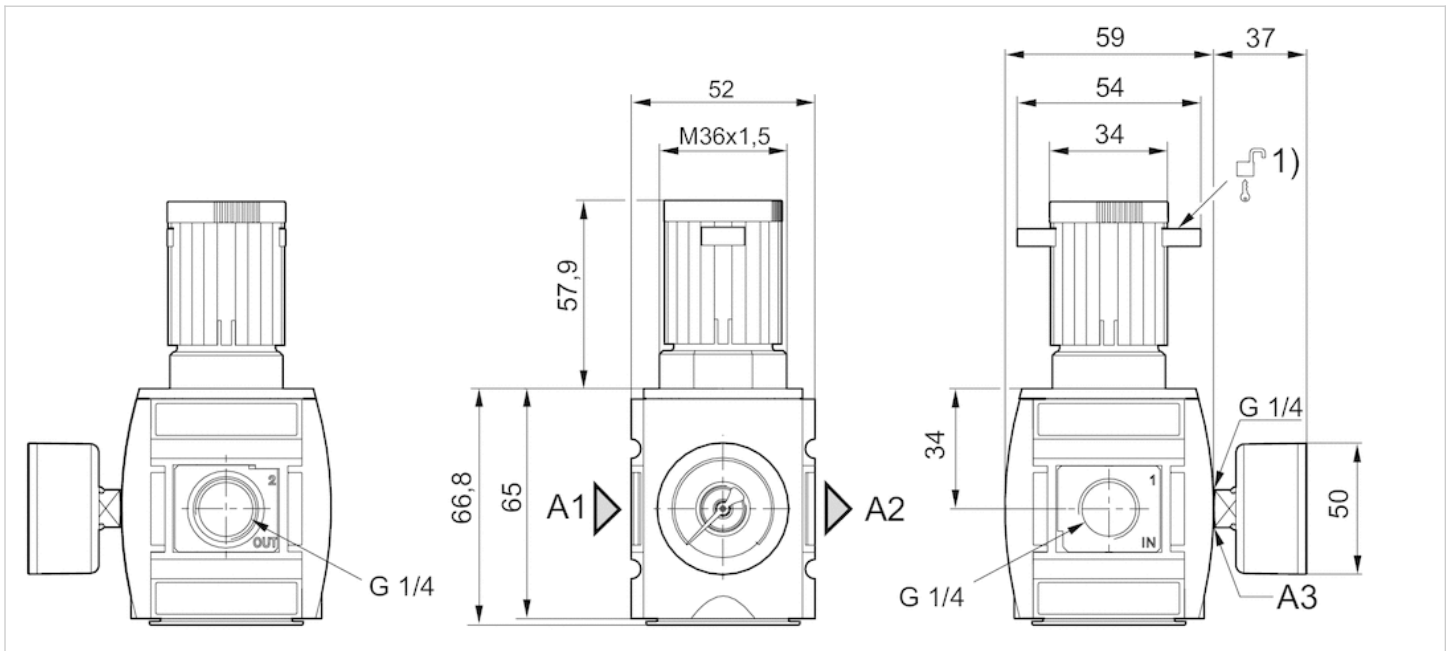

- A1 = input
- A2 = output
- A3 = pressure gauge connection
- 1) Mounting option for padlocks, max. shackle Ø 8

Dimensions in mm, Fig. 2

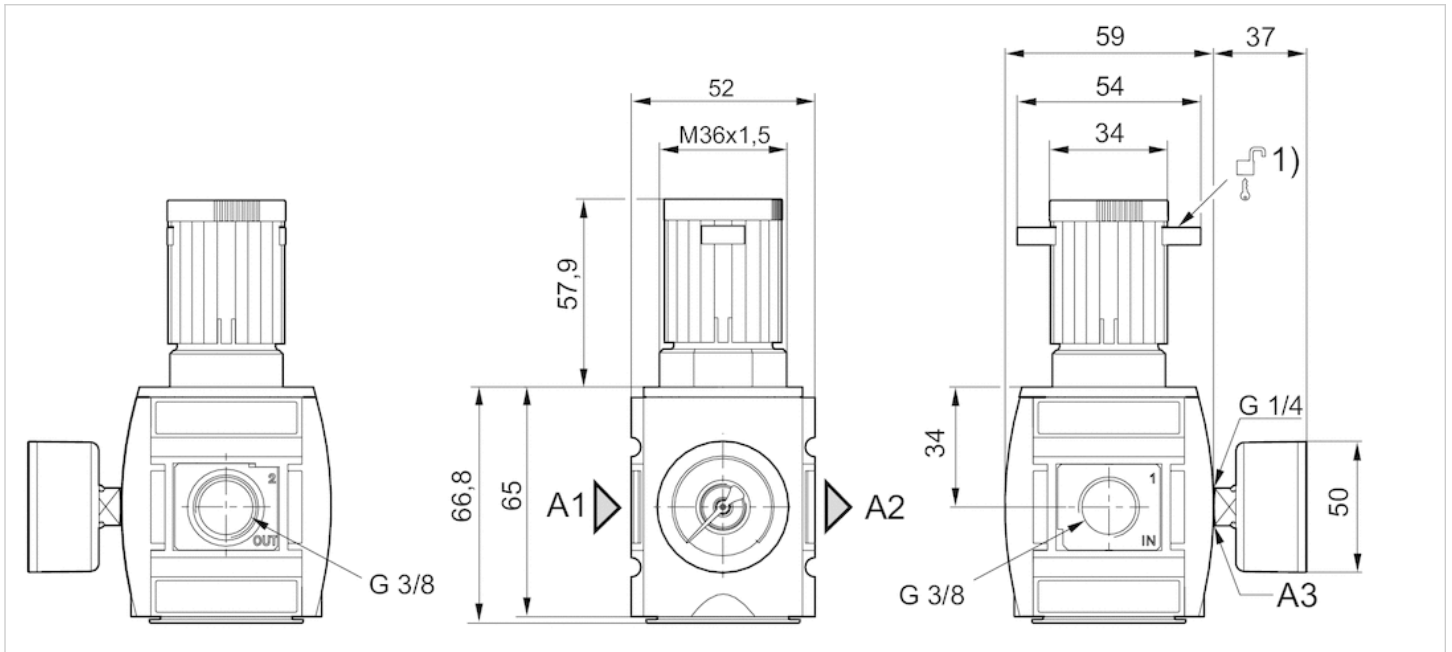

- A1 = input
- A2 = output
- A3 = pressure gauge connection
- 1) Mounting option for padlocks, max. shackle Ø 8

Diagrams

Pressure characteristics curve, Standard version

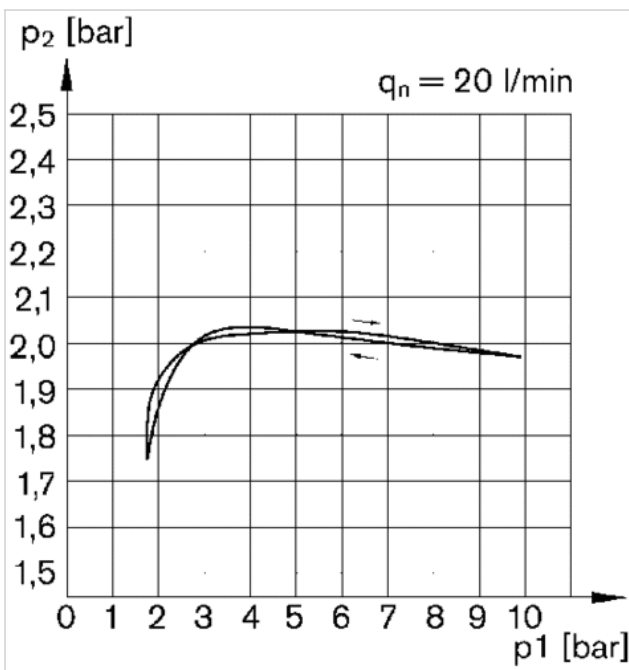

- p1 = Working pressure
- p2 = Secondary pressure
- qn = Nominal flow

Pressure characteristics curve, version with safe rear exhaust in case of drop (removal) of pilot pressure

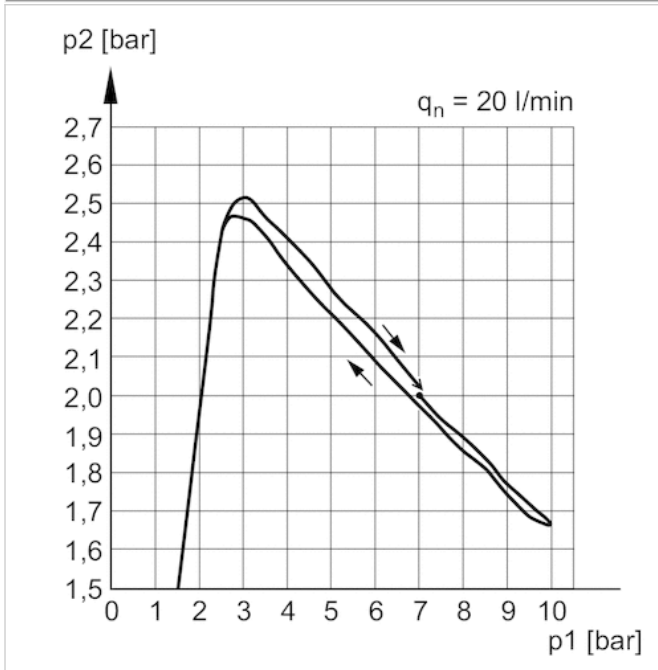

p_1 = Working pressure
 p_2 = Secondary pressure
 q_n = Nominal flow

Flow rate characteristic (p_2 : 0,5 - 8 bar)

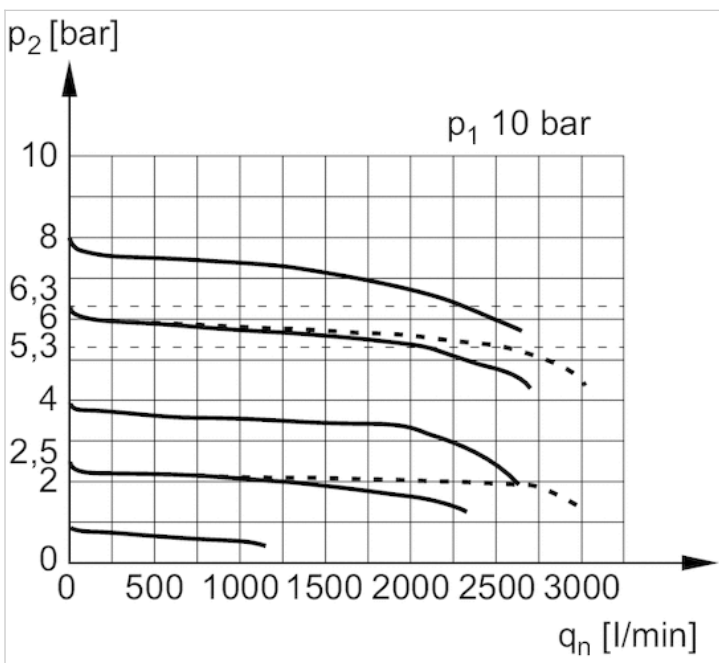

p_1 = Working pressure
 p_2 = Secondary pressure
 q_n = Nominal flow

Accessories overview

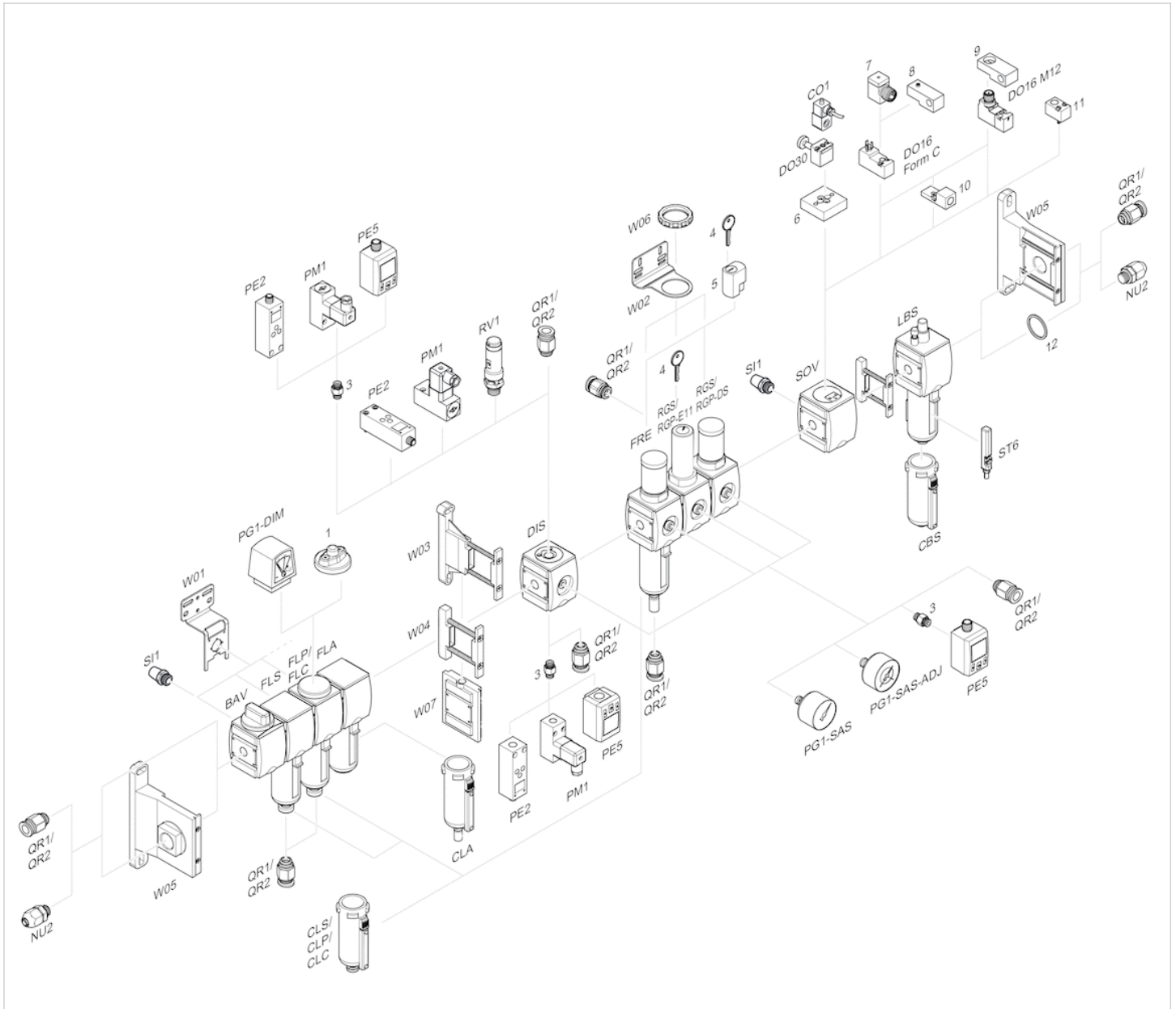

- 1 = contamination display
- 3 = Double nipple
- 4 = Key for E11 locking
- 5 = mortise lock
- 6 = Transition plate DO30
- 7 = Adapter, Series CON-VP
- 8 = Mounting aid DO16, form C
- 9 = Mounting aid DO16, M12
- 10 = Adapter for external pilot air
- 11 = Adapter pneumatic operation
- 12 = Sealing ring

Pressure regulator, Series AS2-RGS-...-E11

- G 1/4
- Qn = 2200 l/min
- Standard pressure regulator
- Activation Mechanical
- lockable
- with E11 locking

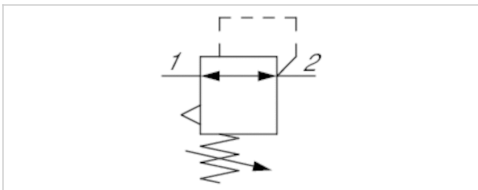

Parts	Pressure regulator
Mounting orientation	Any
Working pressure min./max.	0.5 ... 16 bar
Ambient temperature min./max.	-10 ... 50 °C
Medium temperature min./max.	-10 ... 50 °C
Medium	Compressed air Neutral gases
Regulator type	Diaphragm-type pressure regulator Can be assembled into blocks
Regulator function	with relieving air exhaust
Adjustment range min./max.	0.5 ... 10 bar
Lock type	with E11 locking
Pressure supply	single
Activation	Mechanical
Weight	0.248 kg

Technical data

Part No.	Port	Flow
		Qn
R412006099	G 1/4	2200 l/min

Order pressure gauge separately, Nominal flow Qn with secondary pressure p2 = 6 bar at Δp = 1 bar

Technical information

The pressure dew point must be at least 15 °C under ambient and medium temperature and may not exceed 3 °C .
 The rear pressure gauge connection on the pressure regulator is closed with a blanking plug, the front connection is open. Depending on the customer application, a second blanking plug may be necessary. Please order separately (see accessories).
 The E11 locking is delivered without a key (see accessories for keys).
 A change in the flow direction (from air supply on the left to air supply on the right) occurs by rotating installation by 180° about the vertical axis. Please see the operating instructions for further details.
 Relieving exhaust (≤ 0.3 bar over set pressure).
 With rear exhaust (> 3 bar).

Technical information

Material	
Housing	Polyamide
Front plate	Acrylonitrile butadiene styrene
Seals	Acrylonitrile butadiene rubber
Threaded bushing	Die cast zinc

Dimensions

Dimensions

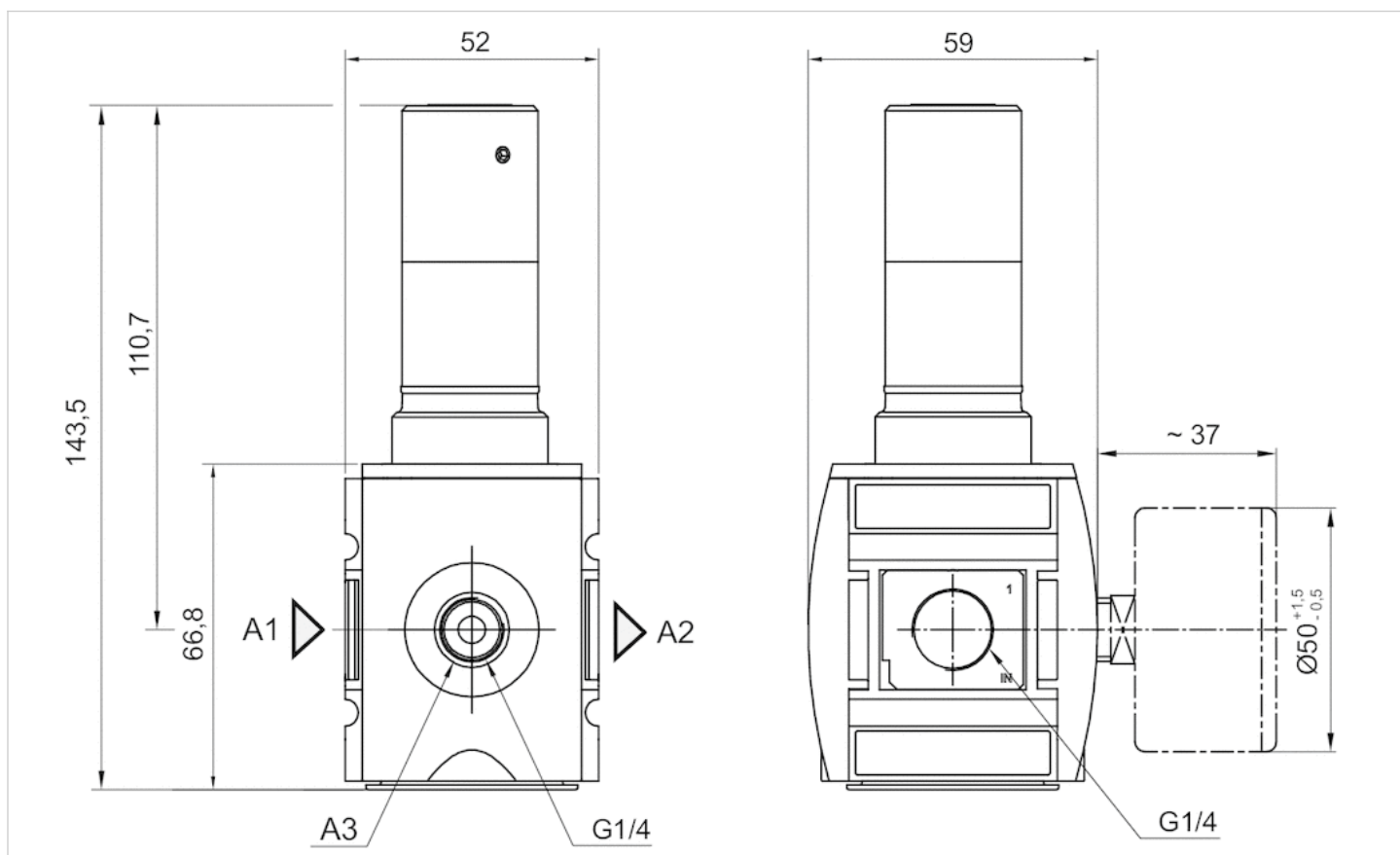

A1 = input

A2 = output

A3 = pressure gauge connection

Diagrams

Pressure characteristics curve, Standard version

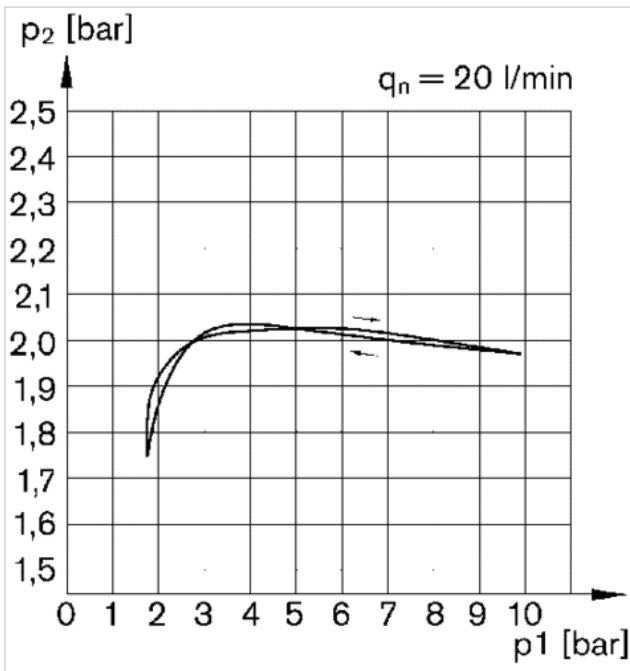

p_1 = Working pressure
 p_2 = Secondary pressure
 q_n = Nominal flow

Flow rate characteristic (p_2 : 0,5 - 8 bar)

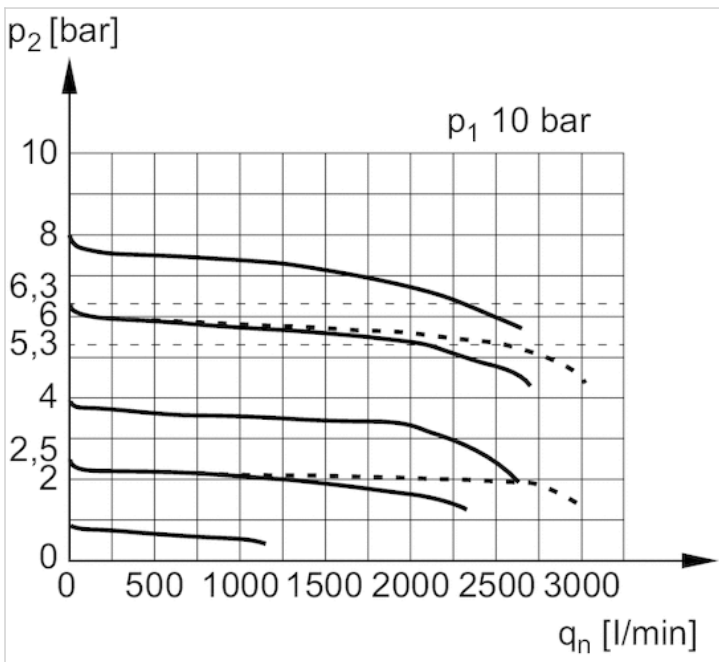

p_1 = Working pressure
 p_2 = Secondary pressure
 q_n = Nominal flow

Accessories overview

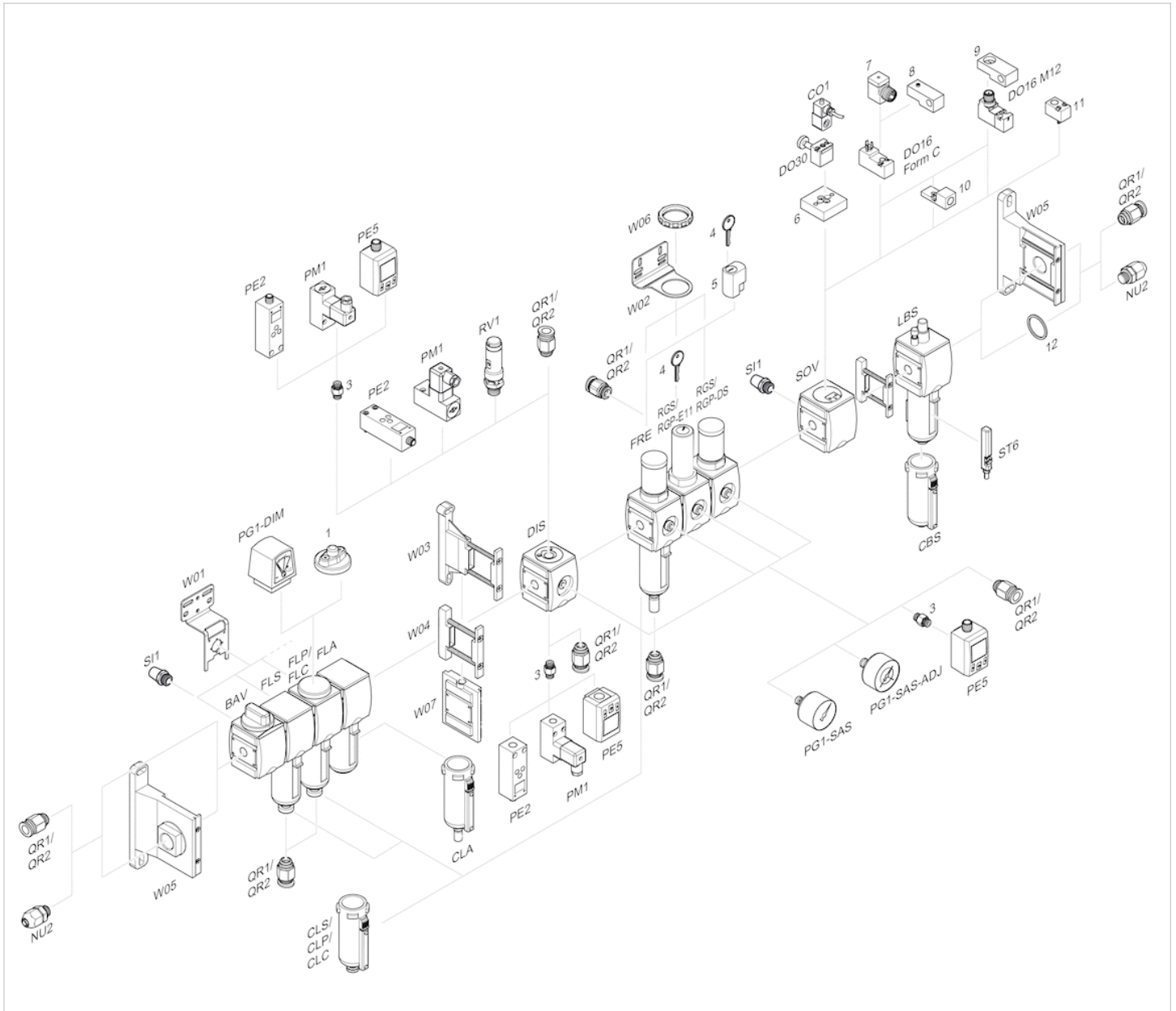

- 1 = contamination display
- 3 = Double nipple
- 4 = Key for E11 locking
- 5 = mortise lock
- 6 = Transition plate DO30
- 7 = Adapter, Series CON-VP
- 8 = Mounting aid DO16, form C
- 9 = Mounting aid DO16, M12
- 10 = Adapter for external pilot air
- 11 = Adapter pneumatic operation
- 12 = Sealing ring

Pressure regulator, Series AS2-RGS-...-DS

- G 1/4 G 3/8
- Qn = 2200-2700 l/min
- Standard pressure regulator
- Activation Mechanical
- with continuous pressure supply
- lockable
- for padlocks
- suitable for ATEX

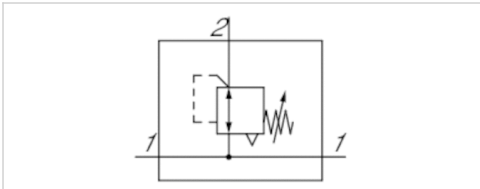

Parts

Mounting orientation

Certificates

Working pressure min./max.

Ambient temperature min./max.

Medium temperature min./max.

Medium

Regulator type

Regulator function

Adjustment range min./max.

Lock type

Pressure supply

Activation

Weight

Pressure regulator with continuous pressure supply

Any

suitable for ATEX

See table below

-10 ... 50 °C

-10 ... 50 °C

Compressed air Neutral gases

Diaphragm-type pressure regulator Can be assembled into blocks

with relieving air exhaust

See table below

for padlocks

double

Mechanical

0.248 kg

Technical data

Part No.	Port	Flow	Working pressure min./max.	Adjustment range min./max.
		Qn		
R412006124	G 1/4	2200 l/min	0.1 ... 16 bar	0.1 ... 1 bar
R412006125	G 1/4	2200 l/min	0.1 ... 16 bar	0.1 ... 2 bar
R412006126	G 1/4	2200 l/min	0.2 ... 16 bar	0.2 ... 4 bar
R412006127	G 1/4	2200 l/min	0.5 ... 16 bar	0.5 ... 8 bar
R412006128	G 1/4	2200 l/min	0.5 ... 16 bar	0.5 ... 10 bar
R412006129	G 1/4	2200 l/min	0.5 ... 16 bar	0.5 ... 16 bar
R412006130	G 3/8	2700 l/min	0.1 ... 16 bar	0.1 ... 1 bar
R412006131	G 3/8	2700 l/min	0.1 ... 16 bar	0.1 ... 2 bar
R412006132	G 3/8	2700 l/min	0.2 ... 16 bar	0.2 ... 4 bar
R412006133	G 3/8	2700 l/min	0.5 ... 16 bar	0.5 ... 8 bar
R412006134	G 3/8	2700 l/min	0.5 ... 16 bar	0.5 ... 10 bar
R412006135	G 3/8	2700 l/min	0.5 ... 16 bar	0.5 ... 16 bar

Part No.	Max. pressure gauge Ø in blocked state	Fig.
R412006124	50 mm	Fig. 1

Part No.	Max. pressure gauge Ø in blocked state	Fig.
R412006125	50 mm	Fig. 1
R412006126	50 mm	Fig. 1
R412006127	50 mm	Fig. 1
R412006128	50 mm	Fig. 1
R412006129	50 mm	Fig. 1
R412006130	50 mm	Fig. 2
R412006131	50 mm	Fig. 2
R412006132	50 mm	Fig. 2
R412006133	50 mm	Fig. 2
R412006134	50 mm	Fig. 2
R412006135	50 mm	Fig. 2

Nominal flow Q_n with secondary pressure $p_2 = 6$ bar at $\Delta p = 1$ bar

Order pressure gauge separately, Suitable for use in Ex zones 1, 2, 21, 22.

Technical information

The pressure dew point must be at least 15 °C under ambient and medium temperature and may not exceed 3 °C .

The rear pressure gauge connection on the pressure regulator is closed with a blanking plug, the front connection is open. Depending on the customer application, a second blanking plug may be necessary. Please order separately (see accessories).

Suitable for use in Ex zones 1, 2, 21, 22.

Relieving exhaust (≤ 0.3 bar over set pressure).

With rear exhaust (> 3 bar).

Technical information

Material	
Housing	Polyamide
Front plate	Acrylonitrile butadiene styrene
Seals	Acrylonitrile butadiene rubber
Threaded bushing	Die cast zinc

Dimensions

Dimensions in mm, Fig. 1

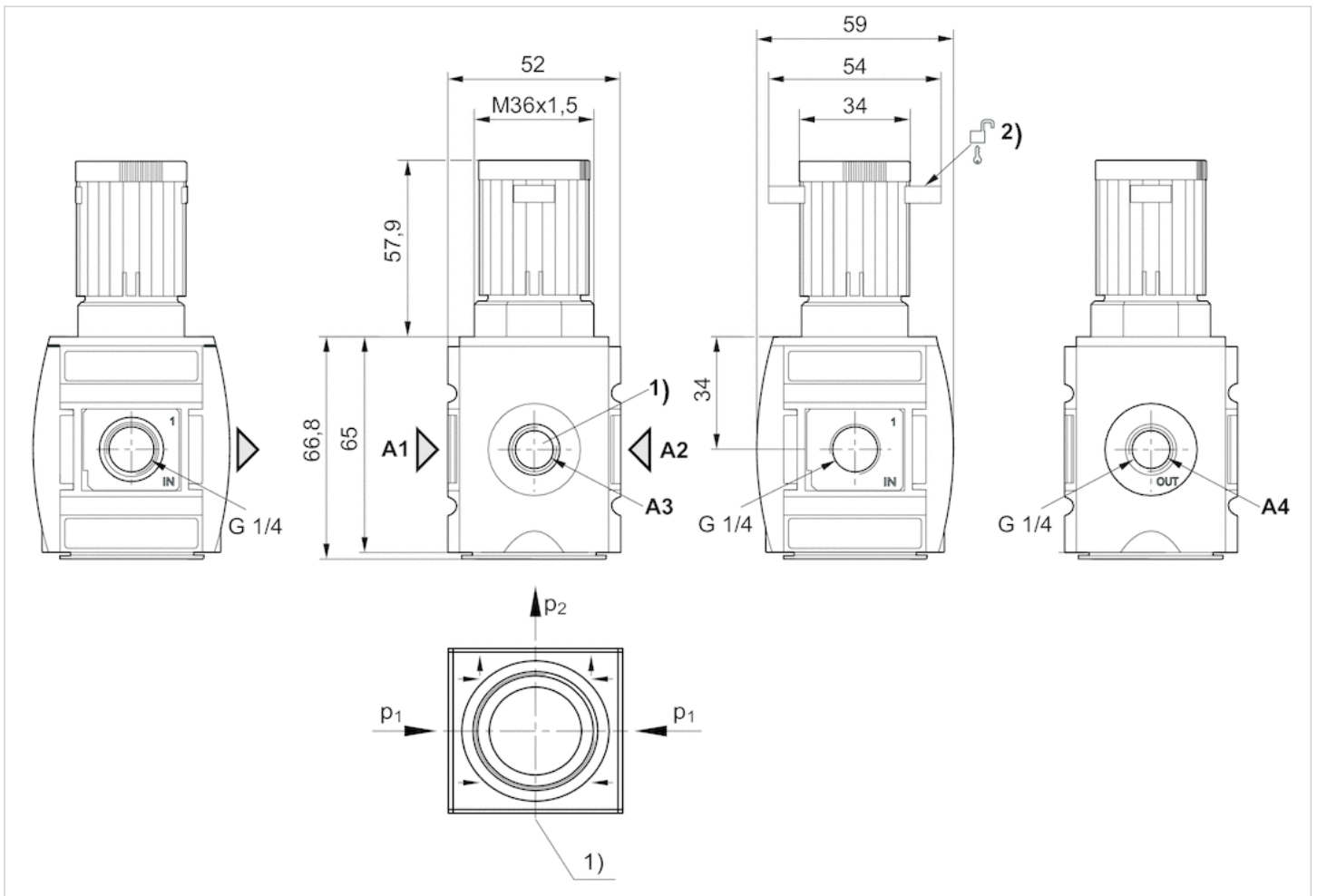

- A1 = input
- A2 = output
- A3 = pressure gauge connection
- A4 = output
- 1) Pressure gauge connection
- 2) Mounting option for padlocks, max. shackle Ø 8

Dimensions in mm, Fig. 2

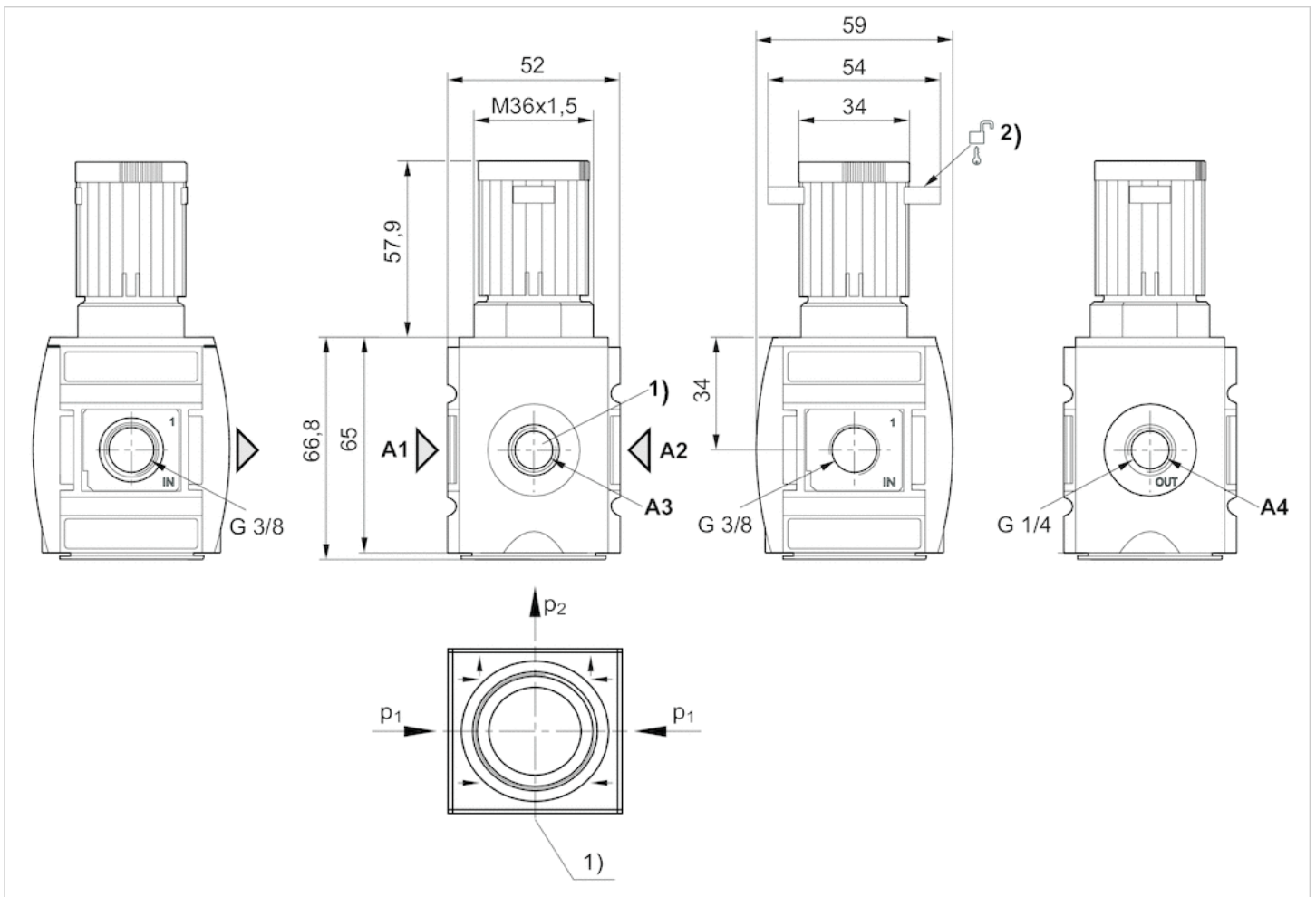

- A1 = input
- A2 = output
- A3 = pressure gauge connection
- A4 = output
- 1) Pressure gauge connection
- 2) Mounting option for padlocks, max. shackle Ø 8

Diagrams

Application example

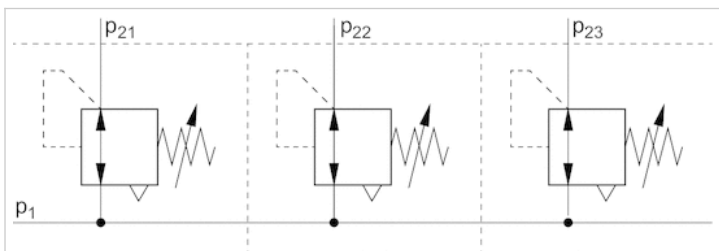

p₁ = working pressure

Pressure characteristics curve

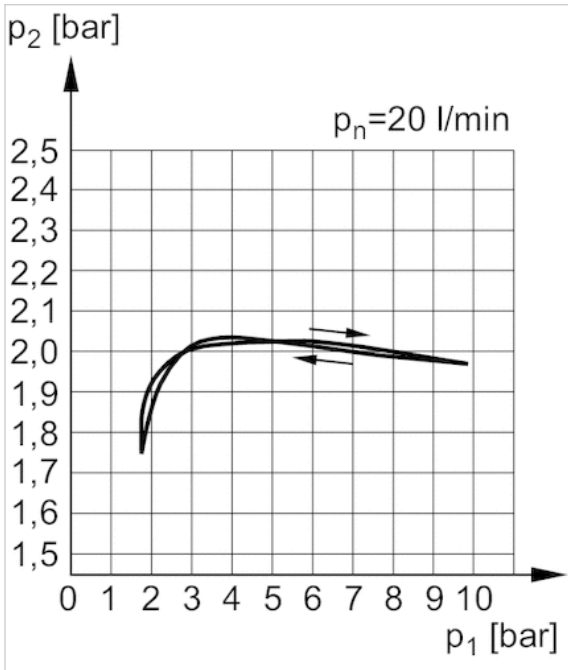

p_1 = Working pressure
 p_2 = Secondary pressure
 q_n = Nominal flow

Flow rate characteristic $p_2: 0,5 - 10 \text{ bar}$

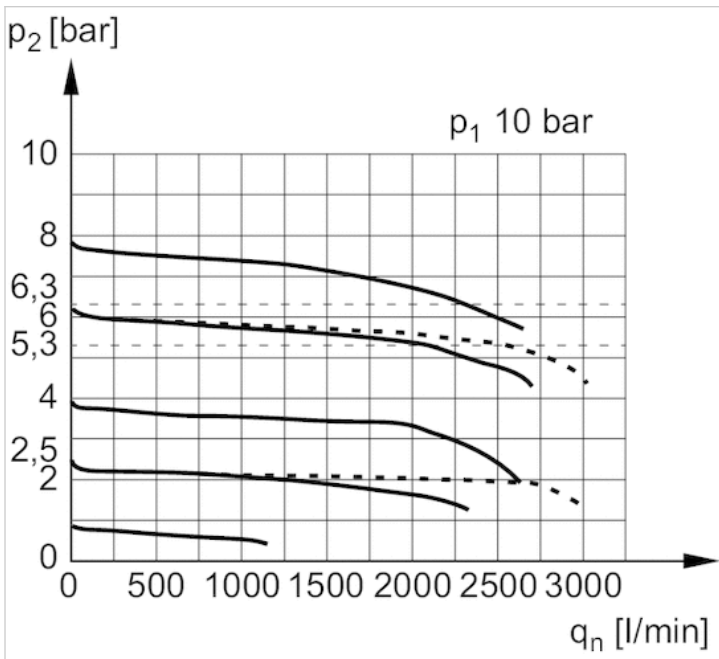

p_1 = Working pressure
 p_2 = Secondary pressure
 q_n = Nominal flow

Accessories overview

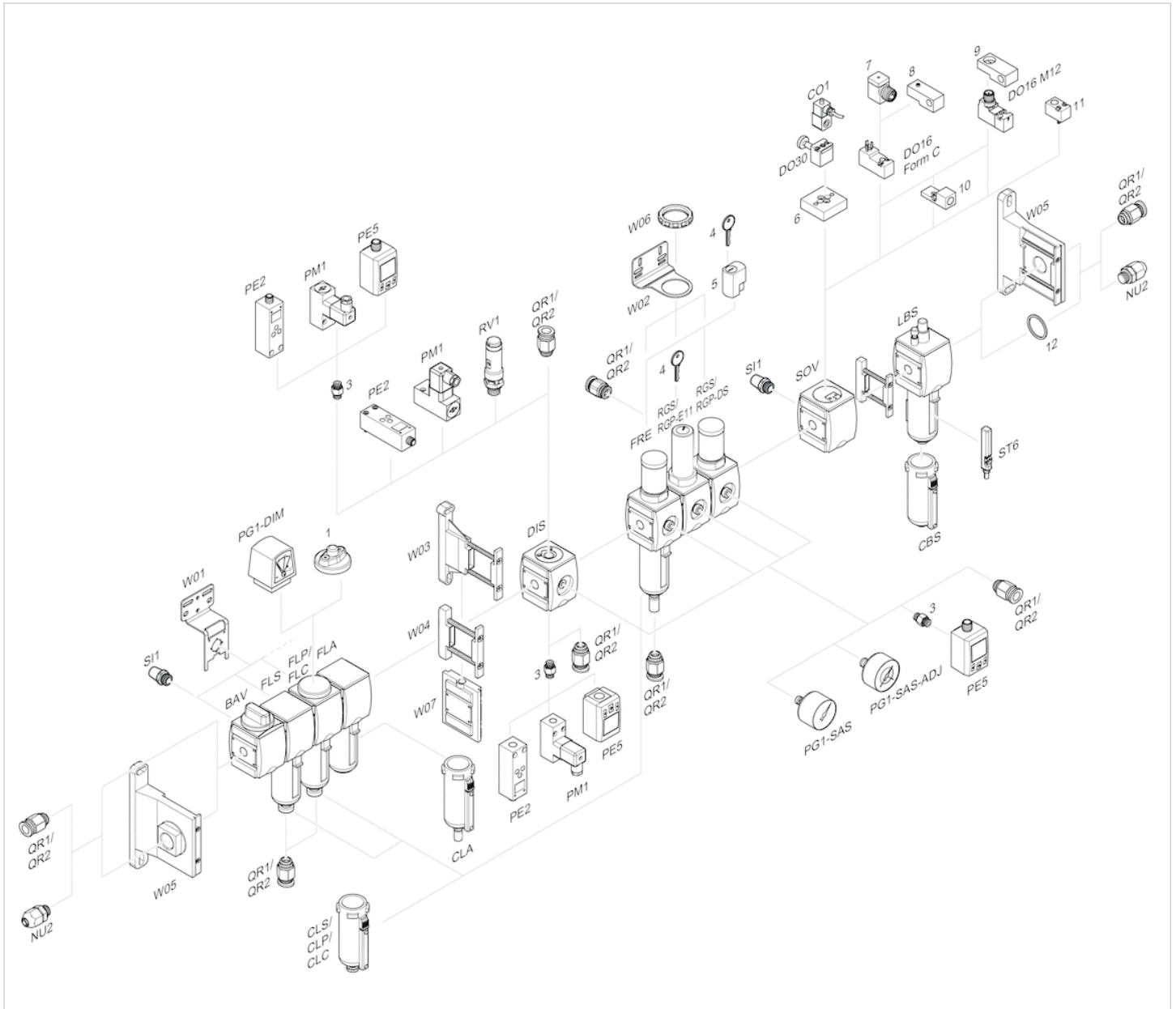

- 1 = contamination display
- 3 = Double nipple
- 4 = Key for E11 locking
- 5 = mortise lock
- 6 = Transition plate DO30
- 7 = Adapter, Series CON-VP
- 8 = Mounting aid DO16, form C
- 9 = Mounting aid DO16, M12
- 10 = Adapter for external pilot air
- 11 = Adapter pneumatic operation
- 12 = Sealing ring

Precision pressure regulator, Series AS2-RGP

- G 1/4 G 3/8
- Qn = 2200-2700 l/min
- Precision pressure regulator
- Activation Mechanical
- lockable
- for padlocks
- suitable for ATEX



Parts	Precision pressure regulator
Mounting orientation	Any
Certificates	suitable for ATEX
Working pressure min./max.	See table below
Ambient temperature min./max.	-10 ... 50 °C
Medium temperature min./max.	-10 ... 50 °C
Medium	Compressed air Neutral gases
Regulator type	Diaphragm-type pressure regulator Can be assembled into blocks
Regulator function	with relieving air exhaust
Adjustment range min./max.	See table below
Lock type	for padlocks
Pressure supply	single
Activation	Mechanical
Weight	See table below

Technical data

Part No.			Port	Flow	Working pressure min./max.	Adjustment range min./max.
				Qn		
R412006137			G 1/4	2200 l/min	0.1 ... 16 bar	0.1 ... 1 bar
R412006139			G 1/4	2200 l/min	0.1 ... 16 bar	0.1 ... 2 bar
R412006141			G 1/4	2200 l/min	0.2 ... 16 bar	0.2 ... 4 bar
R412006143			G 1/4	2200 l/min	0.5 ... 16 bar	0.5 ... 8 bar
R412006145			G 1/4	2200 l/min	0.5 ... 16 bar	0.5 ... 10 bar
R412006136		—	G 1/4	2200 l/min	0.1 ... 16 bar	0.1 ... 1 bar
R412006138		—	G 1/4	2200 l/min	0.1 ... 16 bar	0.1 ... 2 bar
R412006140		—	G 1/4	2200 l/min	0.2 ... 16 bar	0.2 ... 4 bar
R412006142		—	G 1/4	2200 l/min	0.5 ... 16 bar	0.5 ... 8 bar
R412006144		—	G 1/4	2200 l/min	0.5 ... 16 bar	0.5 ... 10 bar
R412006149			G 3/8	2700 l/min	0.1 ... 16 bar	0.1 ... 1 bar
R412006151			G 3/8	2700 l/min	0.1 ... 16 bar	0.1 ... 2 bar
R412006153			G 3/8	2700 l/min	0.2 ... 16 bar	0.2 ... 4 bar
R412006155			G 3/8	2700 l/min	0.5 ... 16 bar	0.5 ... 8 bar
R412006157			G 3/8	2700 l/min	0.5 ... 16 bar	0.5 ... 10 bar
R412006148		—	G 3/8	2700 l/min	0.1 ... 16 bar	0.1 ... 1 bar
R412006150		—	G 3/8	2700 l/min	0.1 ... 16 bar	0.1 ... 2 bar
R412006152		—	G 3/8	2700 l/min	0.2 ... 16 bar	0.2 ... 4 bar
R412006154		—	G 3/8	2700 l/min	0.5 ... 16 bar	0.5 ... 8 bar

Part No.		Port	Flow	Working pressure min./max.	Adjustment range min./max.	
			Qn			
R412006156		—	G 3/8	2700 l/min	0.5 ... 16 bar	0.5 ... 10 bar

Part No.	Weight	Fig.	
R412006137	0.32 kg	Fig. 1	1)
R412006139	0.32 kg	Fig. 1	1)
R412006141	0.32 kg	Fig. 1	1)
R412006143	0.32 kg	Fig. 1	1)
R412006145	0.32 kg	Fig. 1	1)
R412006136	0.248 kg	Fig. 1	2)
R412006138	0.248 kg	Fig. 1	2)
R412006140	0.248 kg	Fig. 1	2)
R412006142	0.248 kg	Fig. 1	2)
R412006144	0.248 kg	Fig. 1	2)
R412006149	0.32 kg	Fig. 2	1)
R412006151	0.32 kg	Fig. 2	1)
R412006153	0.32 kg	Fig. 2	1)
R412006155	0.32 kg	Fig. 2	1)
R412006157	0.32 kg	Fig. 2	1)
R412006148	0.248 kg	Fig. 2	2)
R412006150	0.248 kg	Fig. 2	2)
R412006152	0.248 kg	Fig. 2	2)
R412006154	0.248 kg	Fig. 2	2)
R412006156	0.248 kg	Fig. 2	2)

Nominal flow Qn with secondary pressure p2 = 6 bar at $\Delta p = 1$ bar

- 1) Pressure gauge enclosed separately, Suitable for use in Ex zones 1, 2, 21, 22.
 2) Order pressure gauge separately, Suitable for use in Ex zones 1, 2, 21, 22.

Technical information

The pressure dew point must be at least 15 °C under ambient and medium temperature and may not exceed 3 °C .

The rear pressure gauge connection on the pressure regulator is closed with a blanking plug, the front connection is open. Depending on the customer application, a second blanking plug may be necessary. Please order separately (see accessories).

Suitable for use in Ex zones 1, 2, 21, 22.

A change in the flow direction (from air supply on the left to air supply on the right) occurs by rotating installation by 180° about the vertical axis. Please see the operating instructions for further details.

Recommended pre-filter: 5 µm

Technical information

Material	
Housing	Polyamide
Front plate	Acrylonitrile butadiene styrene
Seals	Acrylonitrile butadiene rubber
Threaded bushing	Die cast zinc

Dimensions

Dimensions in mm, Fig. 1

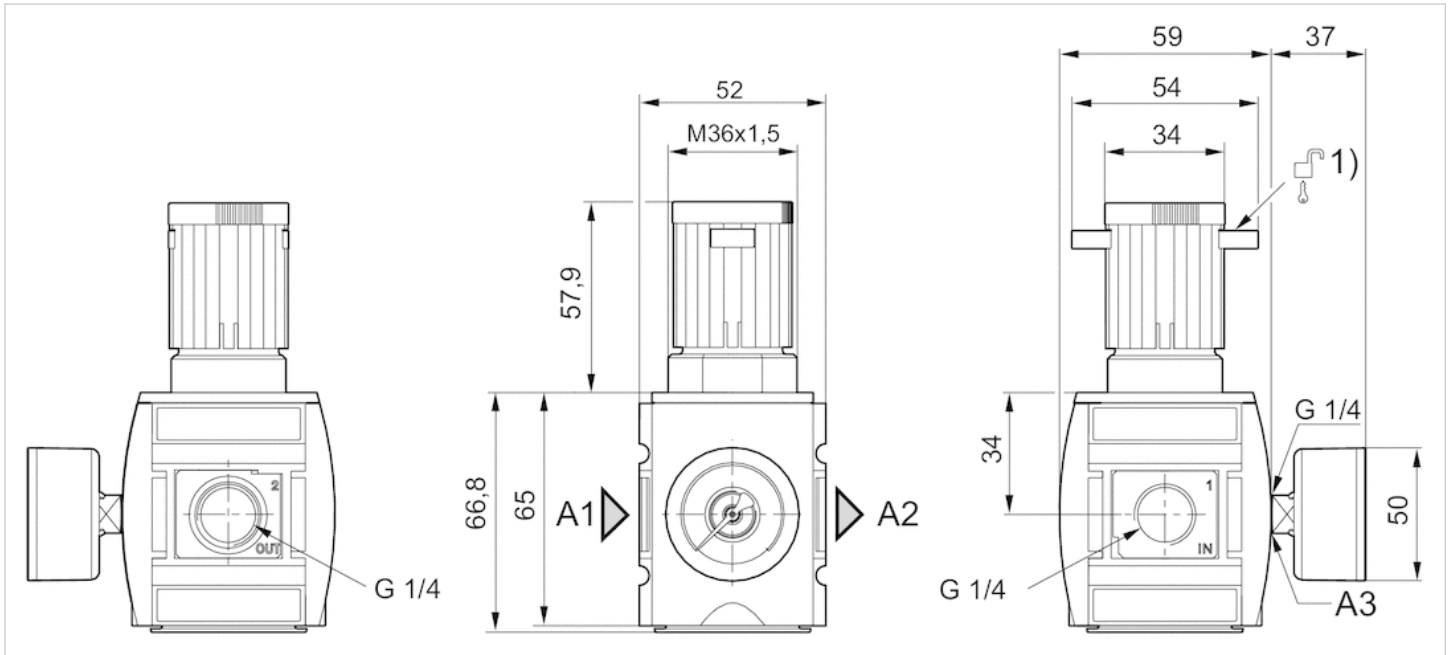

A1 = input

A2 = output

A3 = pressure gauge connection

1) Mounting option for padlocks, max. shackle Ø 8

Dimensions in mm, Fig. 2

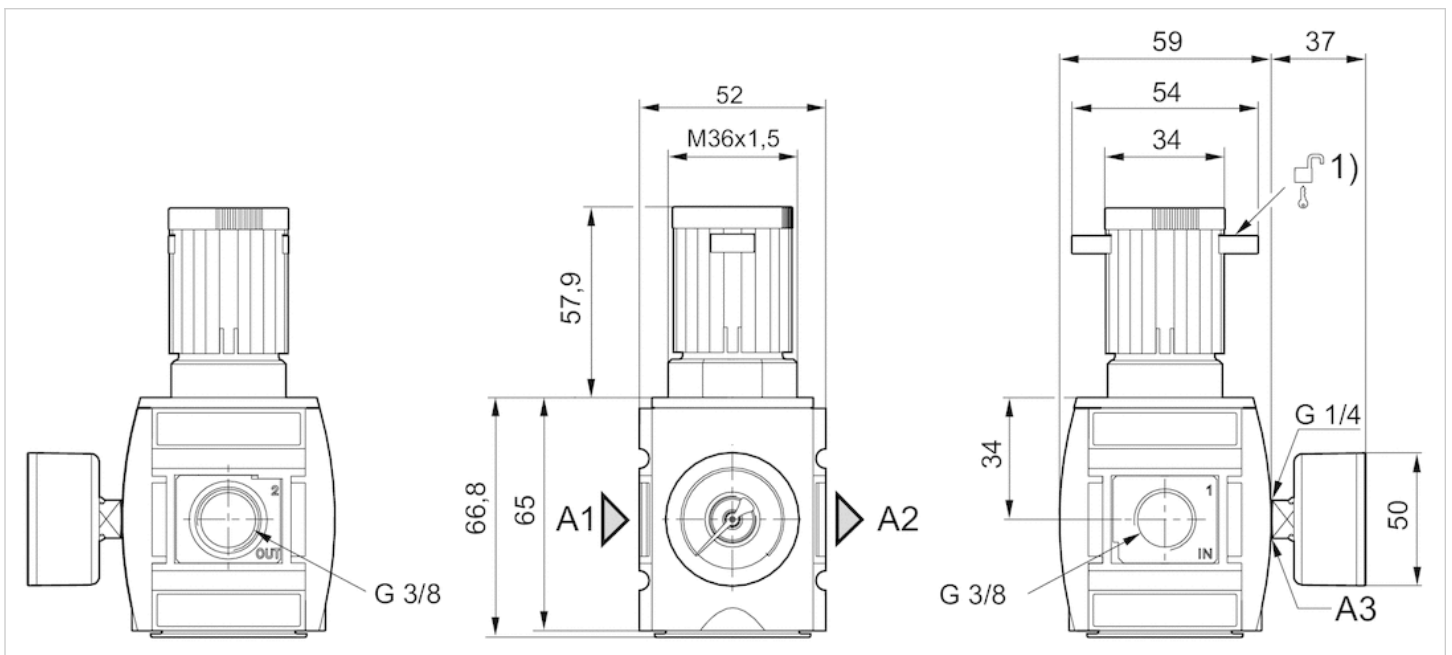

A1 = input

A2 = output

A3 = pressure gauge connection

1) Mounting option for padlocks, max. shackle Ø 8

Diagrams

Pressure characteristics curve

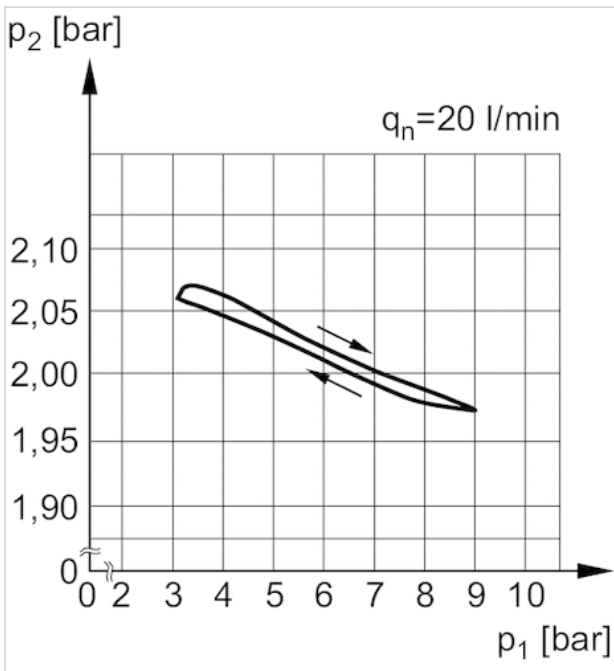

p_1 = working pressure
 p_2 = secondary pressure
 q = flow rate

Flow rate characteristic (p_2 : 0,5 - 8 bar)

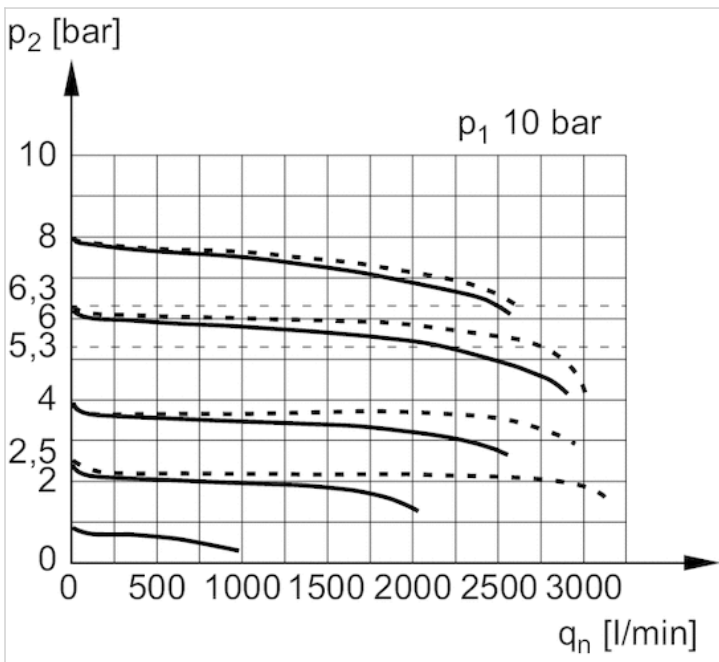

p_1 = Working pressure
 p_2 = Secondary pressure
 q_n = Nominal flow

Accessories overview

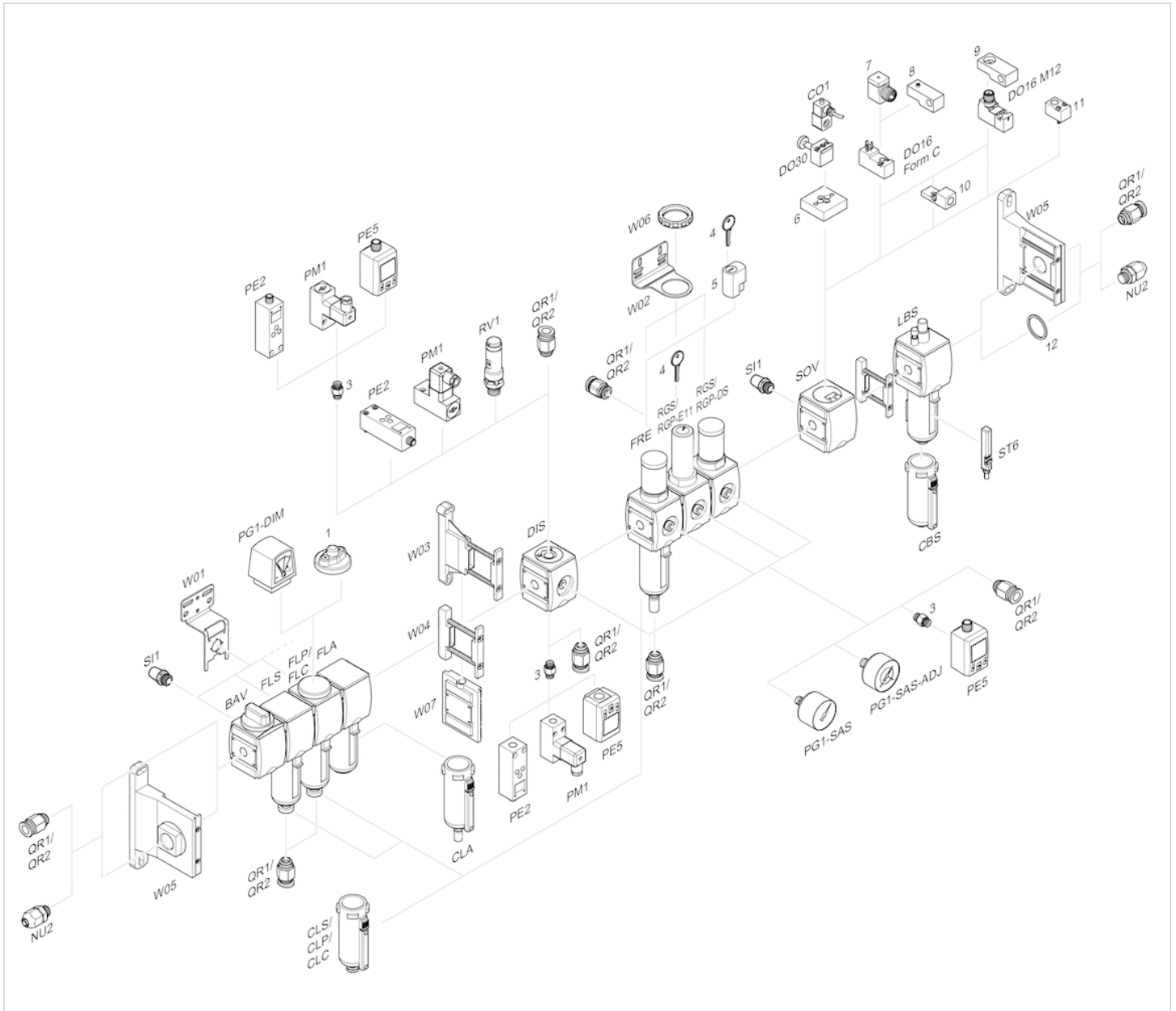

- 1 = contamination display
- 3 = Double nipple
- 4 = Key for E11 locking
- 5 = mortise lock
- 6 = Transition plate DO30
- 7 = Adapter, Series CON-VP
- 8 = Mounting aid DO16, form C
- 9 = Mounting aid DO16, M12
- 10 = Adapter for external pilot air
- 11 = Adapter pneumatic operation
- 12 = Sealing ring

Precision pressure regulator, Series AS2-RGP-...-E11

- G 1/4
- Qn = 2200 l/min
- Precision pressure regulator
- Activation Mechanical
- lockable
- with E11 locking

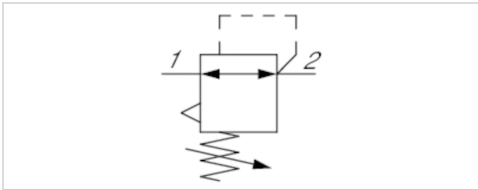

Parts	Precision pressure regulator
Mounting orientation	Any
Working pressure min./max.	0.2 ... 16 bar
Ambient temperature min./max.	-10 ... 50 °C
Medium temperature min./max.	-10 ... 50 °C
Medium	Compressed air Neutral gases
Regulator type	Diaphragm-type pressure regulator Can be assembled into blocks with relieving air exhaust
Regulator function	with relieving air exhaust
Adjustment range min./max.	0.2 ... 4 bar
Lock type	with E11 locking
Pressure supply	single
Activation	Mechanical
Internal air consumption qv max.	2.6 l/min
Weight	0.248 kg

Technical data

Part No.	Port	Flow
		Qn
R412006146	G 1/4	2200 l/min

Order pressure gauge separately, Nominal flow Qn with secondary pressure p2 = 6 bar at $\Delta p = 1$ bar

Technical information

The pressure dew point must be at least 15 °C under ambient and medium temperature and may not exceed 3 °C .
 The rear pressure gauge connection on the pressure regulator is closed with a blanking plug, the front connection is open. Depending on the customer application, a second blanking plug may be necessary. Please order separately (see accessories).
 The E11 locking is delivered without a key (see accessories for keys).
 A change in the flow direction (from air supply on the left to air supply on the right) occurs by rotating installation by 180° about the vertical axis. Please see the operating instructions for further details.
 Recommended pre-filter: 5 µm

Technical information

Material	
Housing	Polyamide
Front plate	Acrylonitrile butadiene styrene
Seals	Acrylonitrile butadiene rubber
Threaded bushing	Die cast zinc

Dimensions

Dimensions

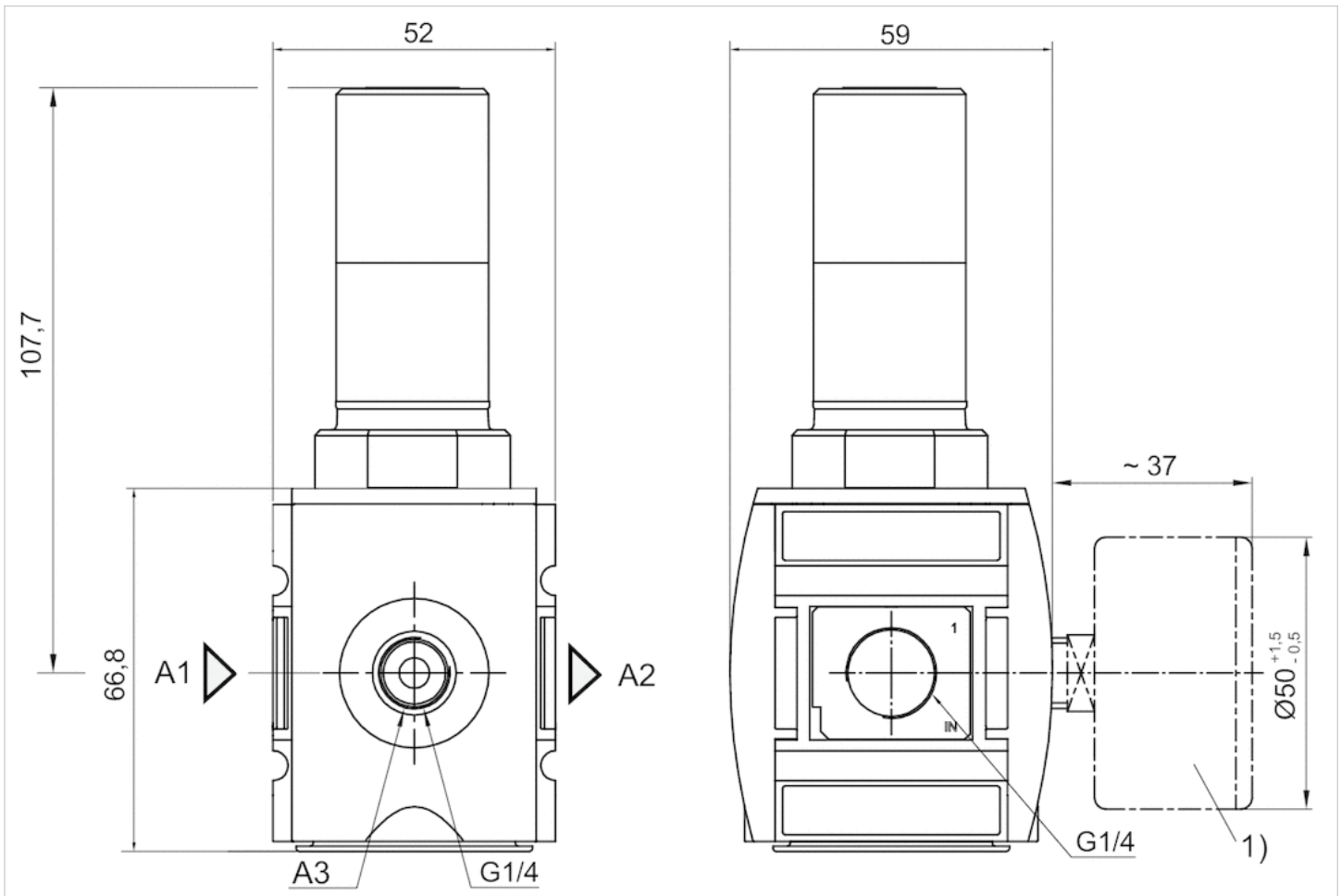

A1 = input
 A2 = output
 A3 = pressure gauge connection

Diagrams

Pressure characteristics curve

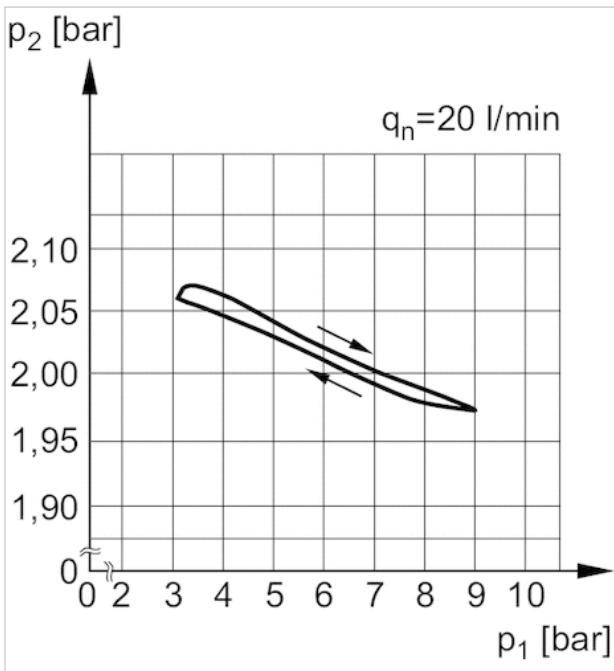

p_1 = working pressure
 p_2 = secondary pressure
 q = flow rate

Flow rate characteristic (p_2 : 0,5 - 8 bar)

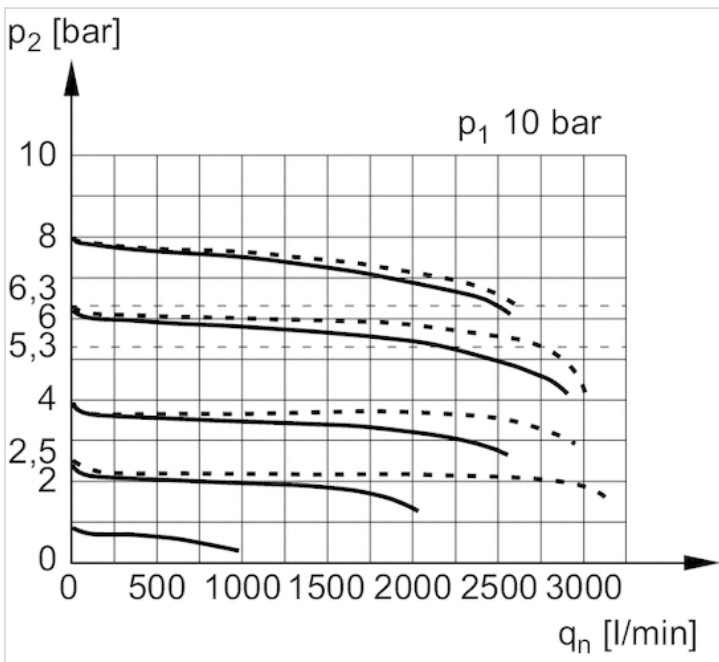

p_1 = Working pressure
 p_2 = Secondary pressure
 q_n = Nominal flow

Accessories overview

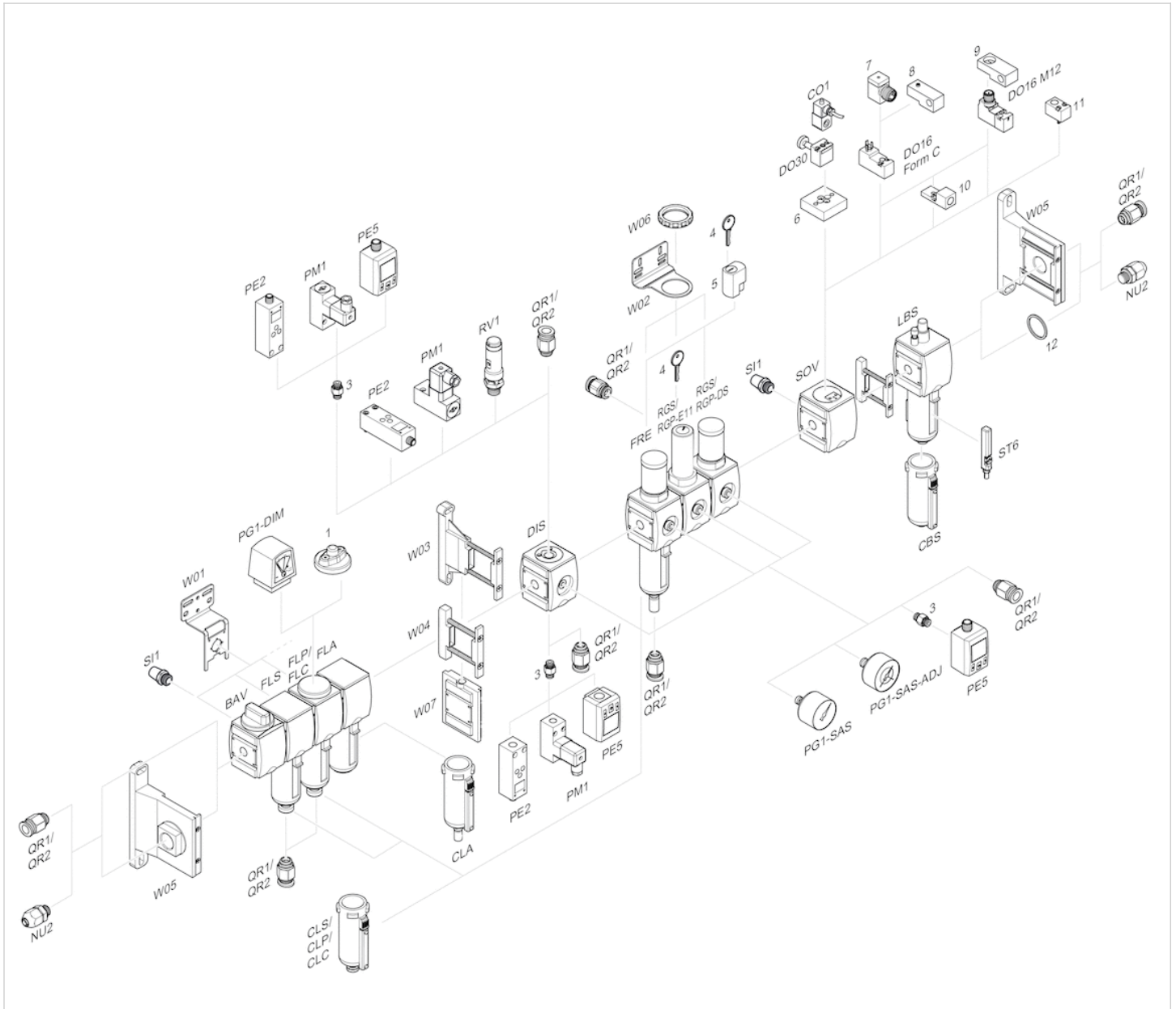

- 1 = contamination display
- 3 = Double nipple
- 4 = Key for E11 locking
- 5 = mortise lock
- 6 = Transition plate DO30
- 7 = Adapter, Series CON-VP
- 8 = Mounting aid DO16, form C
- 9 = Mounting aid DO16, M12
- 10 = Adapter for external pilot air
- 11 = Adapter pneumatic operation
- 12 = Sealing ring

Precision pressure regulator, Series AS2-RGP-...-DS

- G 1/4 G 3/8
- Qn = 2200-2700 l/min
- Precision pressure regulator
- Activation Mechanical
- with continuous pressure supply
- lockable
- suitable for ATEX

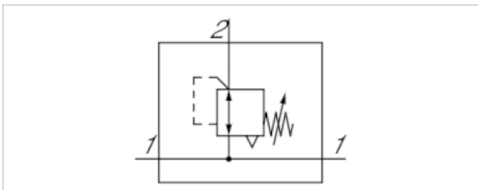

Parts

Mounting orientation

Certificates

Working pressure min./max.

Ambient temperature min./max.

Medium temperature min./max.

Medium

Regulator type

Regulator function

Adjustment range min./max.

Pressure supply

Activation

Weight

Precision pressure regulator with continuous pressure supply

Any

suitable for ATEX

See table below

-10 ... 50 °C

-10 ... 50 °C

Compressed air Neutral gases

Diaphragm-type pressure regulator Can be assembled into blocks

with relieving air exhaust

See table below

double

Mechanical

0.248 kg

Technical data

Part No.	Port	Flow	Working pressure min./max.	Adjustment range min./max.
		Qn		
R412006160	G 1/4	2200 l/min	0.1 ... 16 bar	0.1 ... 1 bar
R412006161	G 1/4	2200 l/min	0.1 ... 16 bar	0.1 ... 2 bar
R412006162	G 1/4	2200 l/min	0.2 ... 16 bar	0.2 ... 4 bar
R412006163	G 1/4	2200 l/min	0.5 ... 16 bar	0.5 ... 8 bar
R412006164	G 1/4	2200 l/min	0.5 ... 16 bar	0.5 ... 10 bar
R412006166	G 3/8	2700 l/min	0.1 ... 16 bar	0.1 ... 1 bar
R412006167	G 3/8	2700 l/min	0.1 ... 16 bar	0.1 ... 2 bar
R412006168	G 3/8	2700 l/min	0.2 ... 16 bar	0.2 ... 4 bar
R412006169	G 3/8	2700 l/min	0.5 ... 16 bar	0.5 ... 8 bar
R412006170	G 3/8	2700 l/min	0.5 ... 16 bar	0.5 ... 10 bar

Part No.	Max. pressure gauge Ø in blocked state	Fig.
R412006160	50 mm	Fig. 1
R412006161	50 mm	Fig. 1
R412006162	50 mm	Fig. 1
R412006163	50 mm	Fig. 1

Part No.	Max. pressure gauge Ø in blocked state	Fig.
R412006164	50 mm	Fig. 1
R412006166	50 mm	Fig. 2
R412006167	50 mm	Fig. 2
R412006168	50 mm	Fig. 2
R412006169	50 mm	Fig. 2
R412006170	50 mm	Fig. 2

Nominal flow Q_n with secondary pressure p₂ = 6 bar at Δp = 1 bar

Order pressure gauge separately, Suitable for use in Ex zones 1, 2, 21, 22.

Technical information

The pressure dew point must be at least 15 °C under ambient and medium temperature and may not exceed 3 °C .

The rear pressure gauge connection on the pressure regulator is closed with a blanking plug, the front connection is open. Depending on the customer application, a second blanking plug may be necessary. Please order separately (see accessories).

Suitable for use in Ex zones 1, 2, 21, 22.

Recommended pre-filter: 5 μm

Technical information

Material	
Housing	Polyamide
Front plate	Acrylonitrile butadiene styrene
Seals	Acrylonitrile butadiene rubber
Threaded bushing	Die cast zinc

Dimensions

Dimensions in mm, Fig. 1

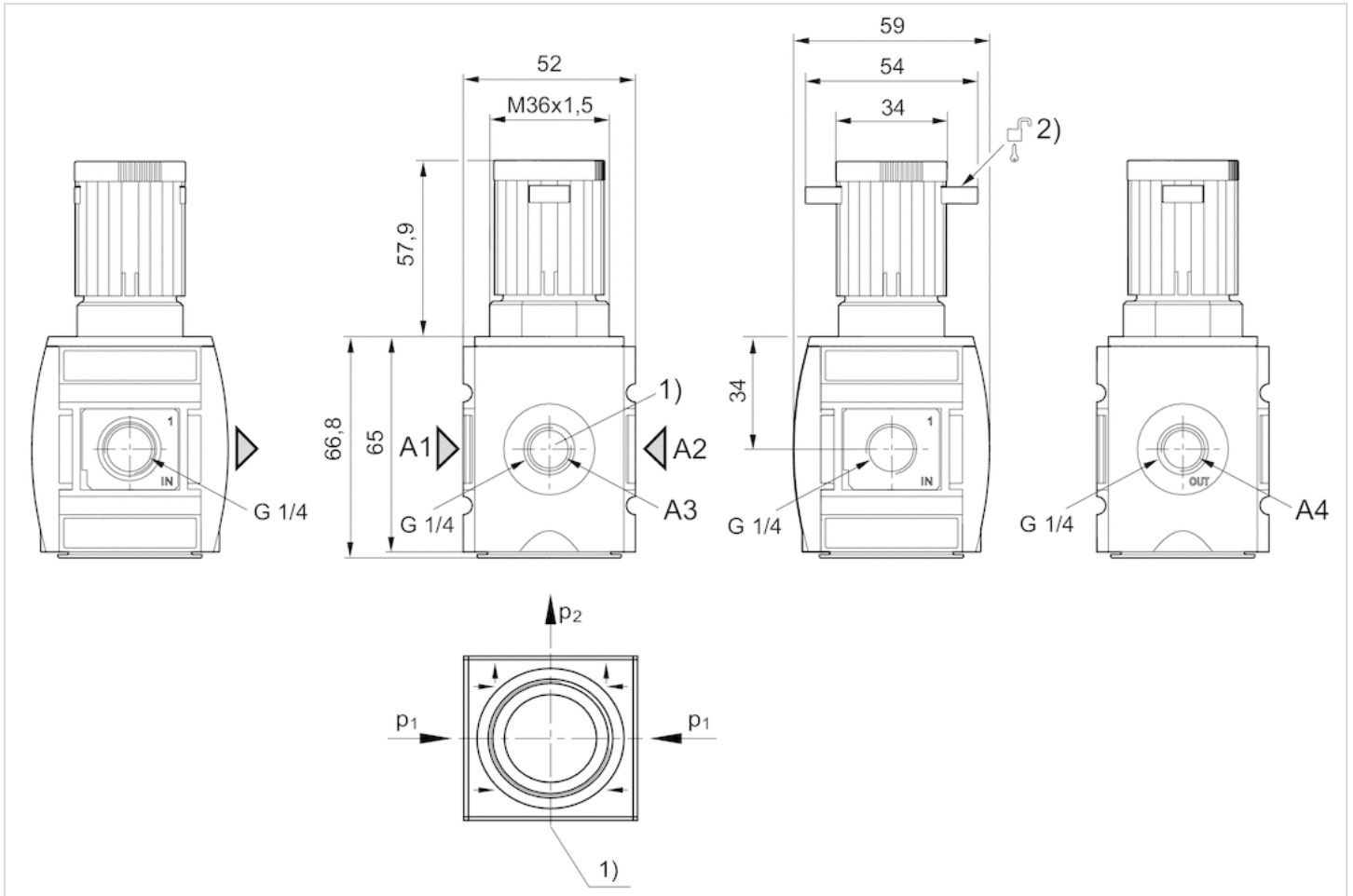

- A1 = input
- A2 = output
- A3 = pressure gauge connection
- A4 = output
- 1) Pressure gauge connection
- 2) Mounting option for padlocks, max. shackle Ø 8

Pressure characteristics curve

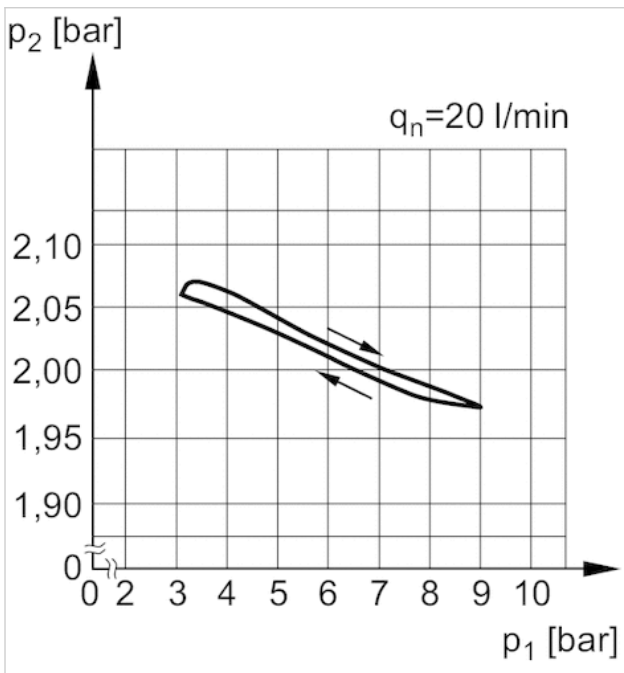

p_1 = Working pressure
 p_2 = Secondary pressure
 q_n = Nominal flow

Flow rate characteristic (p_2 : 0,5 - 8 bar)

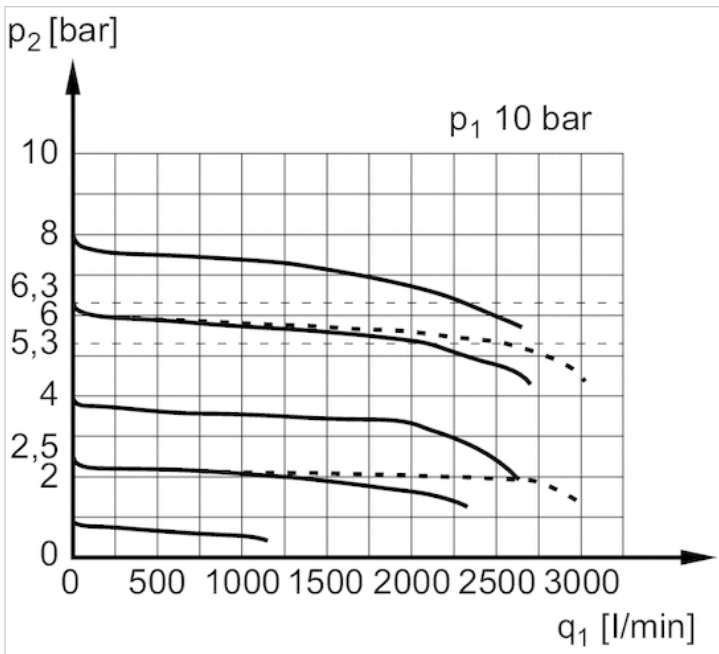

p_1 = Working pressure
 p_2 = Secondary pressure
 q_n = Nominal flow

Accessories overview

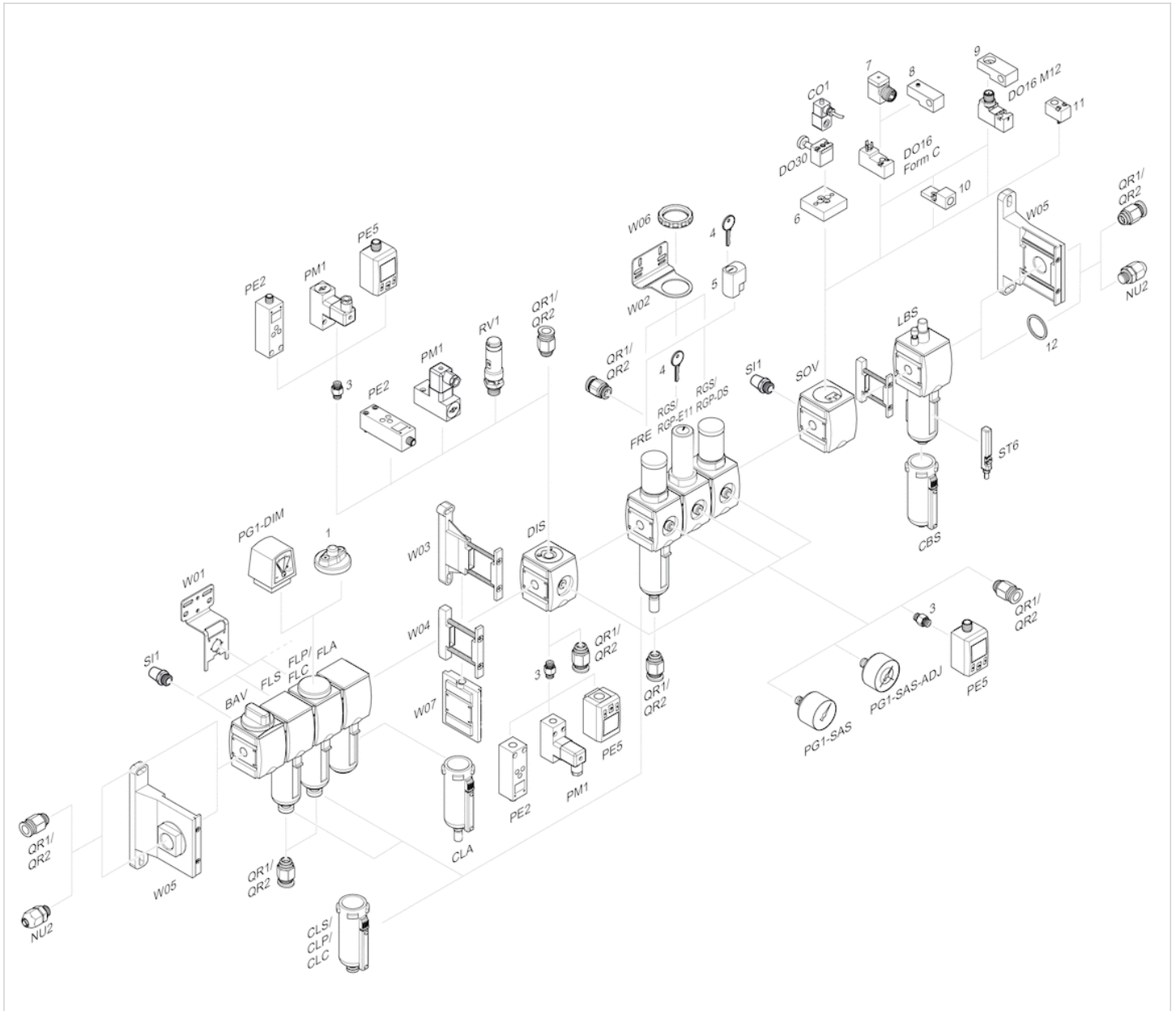

- 1 = contamination display
- 3 = Double nipple
- 4 = Key for E11 locking
- 5 = mortise lock
- 6 = Transition plate DO30
- 7 = Adapter, Series CON-VP
- 8 = Mounting aid DO16, form C
- 9 = Mounting aid DO16, M12
- 10 = Adapter for external pilot air
- 11 = Adapter pneumatic operation
- 12 = Sealing ring

Pressure regulator, Series AS2-RGS

- G 1/4 G 3/8
- $Q_n = 2700$ l/min
- Standard pressure regulator
- Activation pneumatically

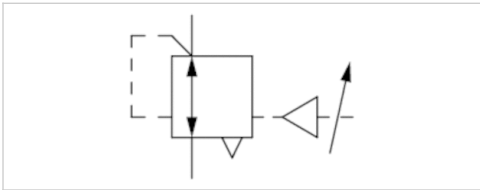

Parts	Pressure regulator
Mounting orientation	Any
Working pressure min./max.	0 ... 16 bar
Ambient temperature min./max.	0 ... 50 °C
Medium temperature min./max.	0 ... 50 °C
Medium	Compressed air Neutral gases
Regulator type	Diaphragm-type pressure regulator Can be assembled into blocks with relieving air exhaust
Regulator function	
Adjustment range min./max.	0.5 ... 16 bar
Pressure supply	single
Activation	pneumatically
Weight	0.314 kg

Technical data

Part No.	Port	Flow	Fig.
		Q_n	
R412006094	G 1/4	2700 l/min	Fig. 1
R412006095	G 3/8	2700 l/min	Fig. 2

Control pressure: see diagram, Nominal flow Q_n with secondary pressure $p_2 = 6$ bar at $\Delta p = 1$ bar

Order pressure gauge separately

Technical information

The pressure dew point must be at least 15 °C under ambient and medium temperature and may not exceed 3 °C .

The rear pressure gauge connection on the pressure regulator is closed with a blanking plug, the front connection is open. Depending on the customer application, a second blanking plug may be necessary. Please order separately (see accessories).

A change in the flow direction (from air supply on the left to air supply on the right) occurs by rotating installation by 180° about the vertical axis. Please see the operating instructions for further details.

Relieving exhaust (≤ 0.3 bar over set pressure).

With rear exhaust (> 3 bar).

Technical information

Material	
Housing	Polyamide
Front plate	Acrylonitrile butadiene styrene

Material	
Seals	Acrylonitrile butadiene rubber
Threaded bushing	Die cast zinc

Dimensions

Dimensions in mm, Fig. 1

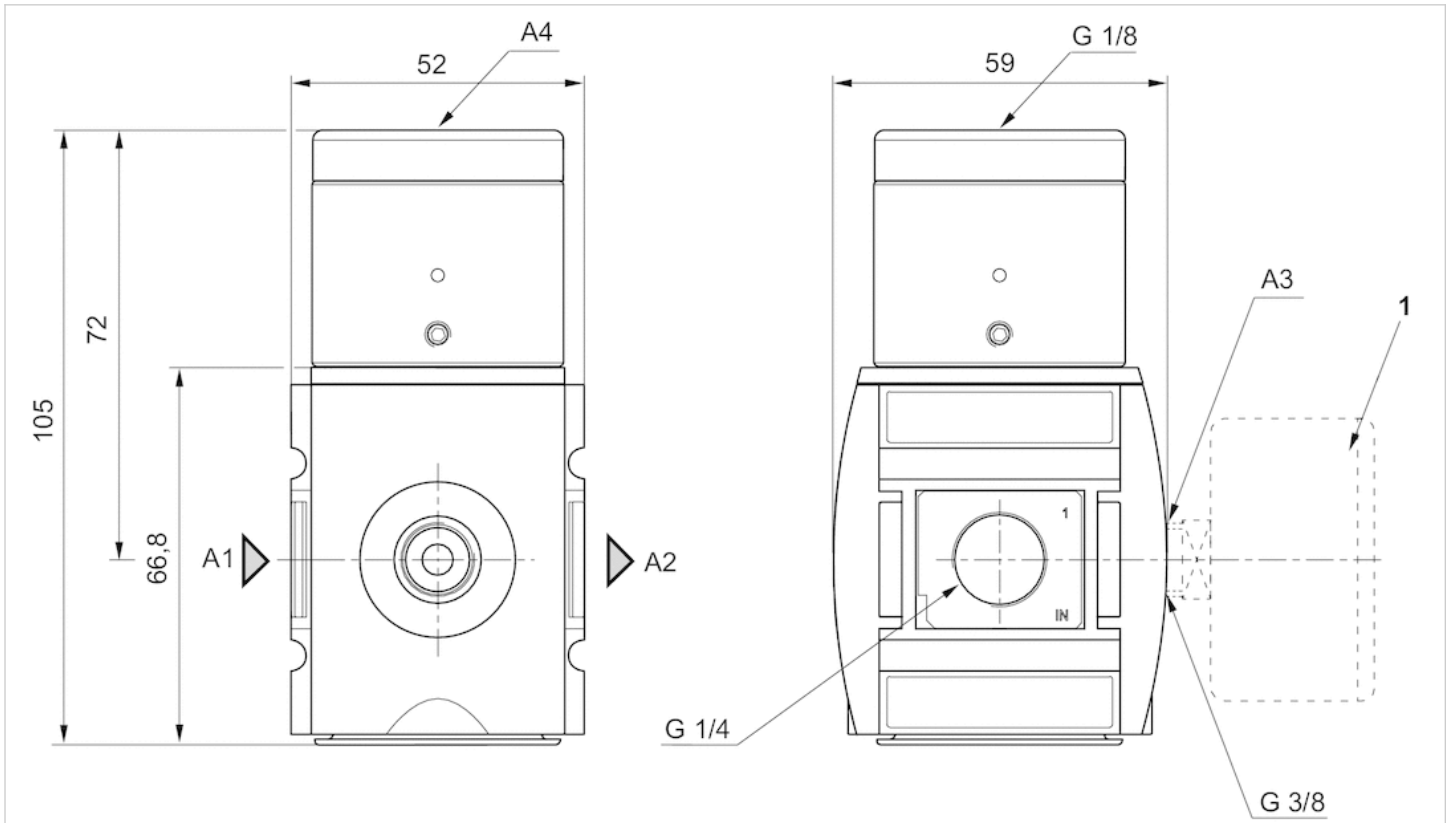

- A1 = input
- A2 = output
- A3 = pressure gauge connection
- A4 = control pressure connection
- 1) Order pressure gauge separately

Dimensions in mm, Fig. 2

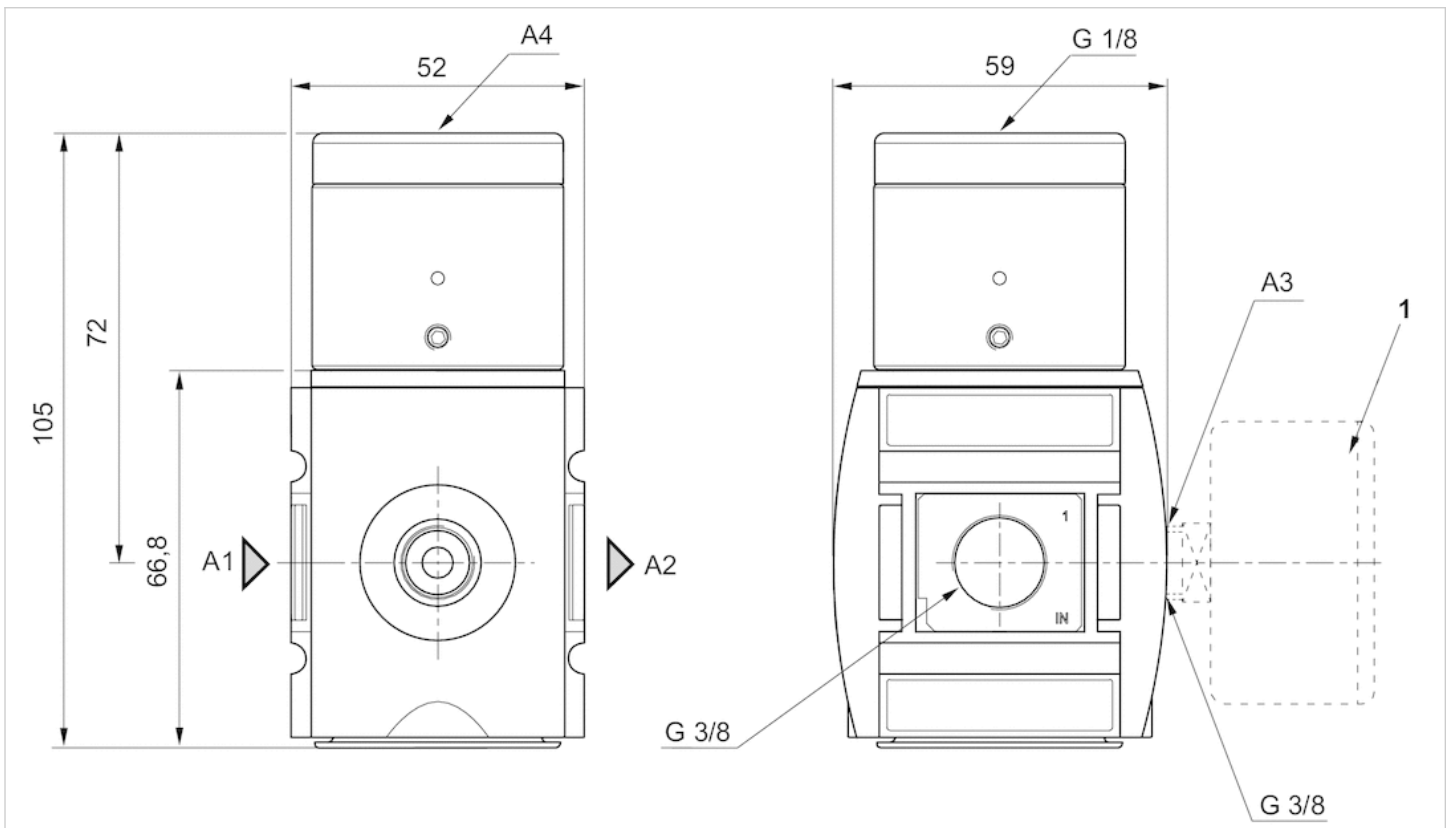

- A1 = input
- A2 = output
- A3 = pressure gauge connection
- A4 = control pressure connection
- 1) Order pressure gauge separately

Diagrams

Pressure characteristics curve

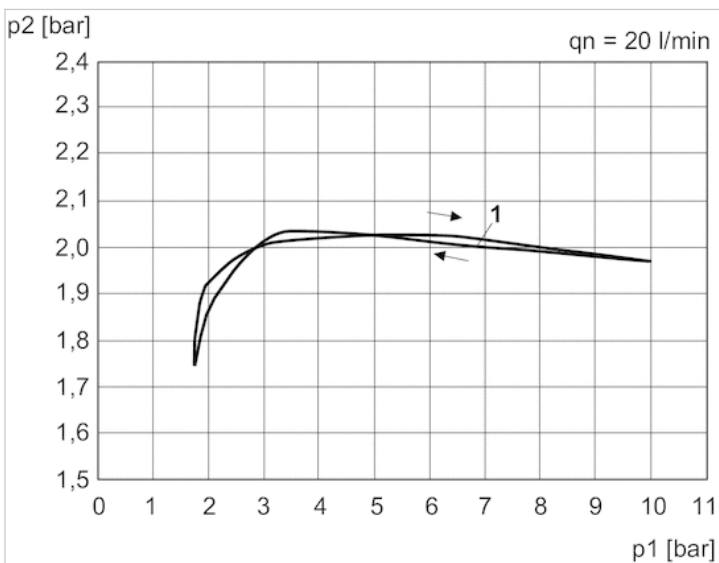

- p1 = Working pressure
- p2 = Secondary pressure
- qn = Nominal flow

1) = Starting point

Flow rate characteristic (p2: 0,5 - 8 bar)

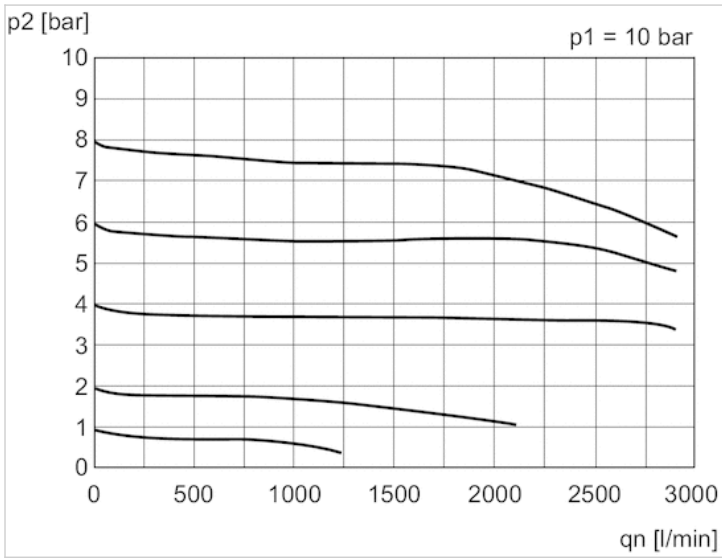

p1 = Working pressure
 p2 = Secondary pressure
 qn = Nominal flow

control pressure characteristic

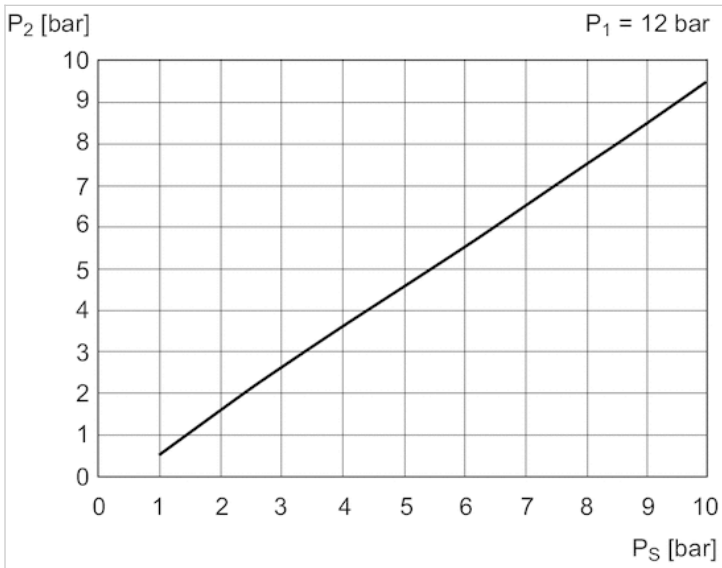

p1 = working pressure
 p2 = secondary pressure
 PS = control pressure

Circuit diagram

Application example

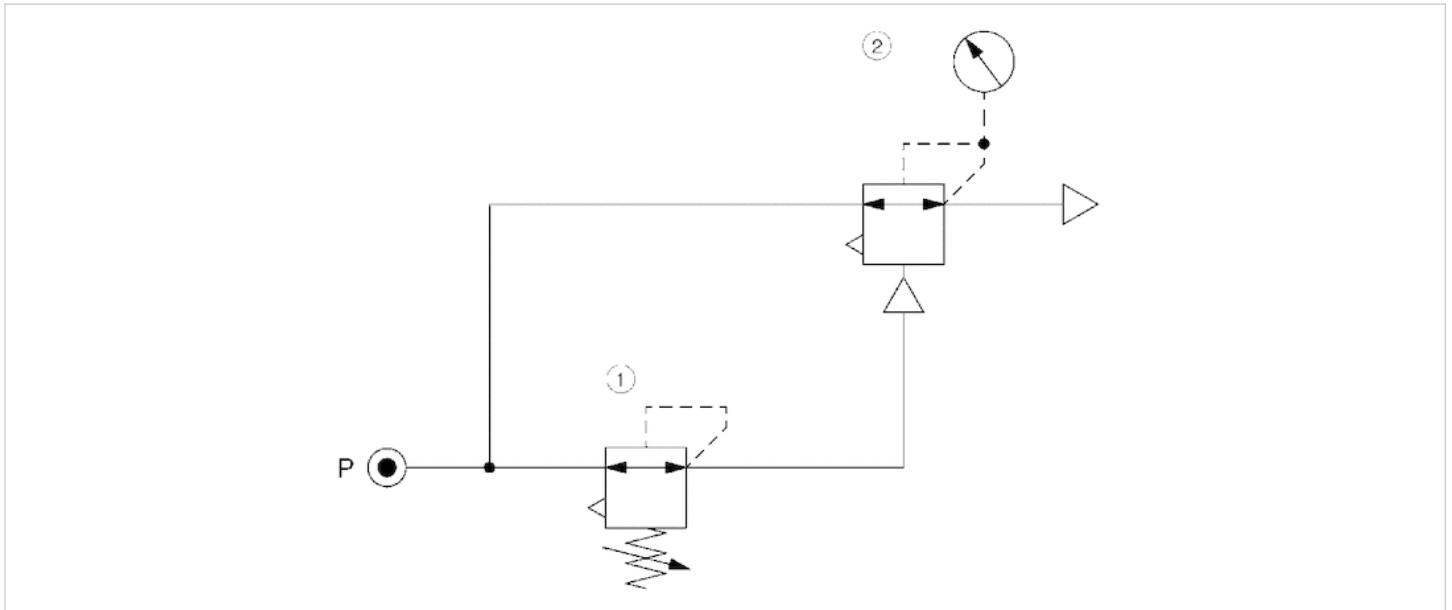

1) precision pressure regulator

2) pressure regulator valve, pneumatically operated

Accessories overview

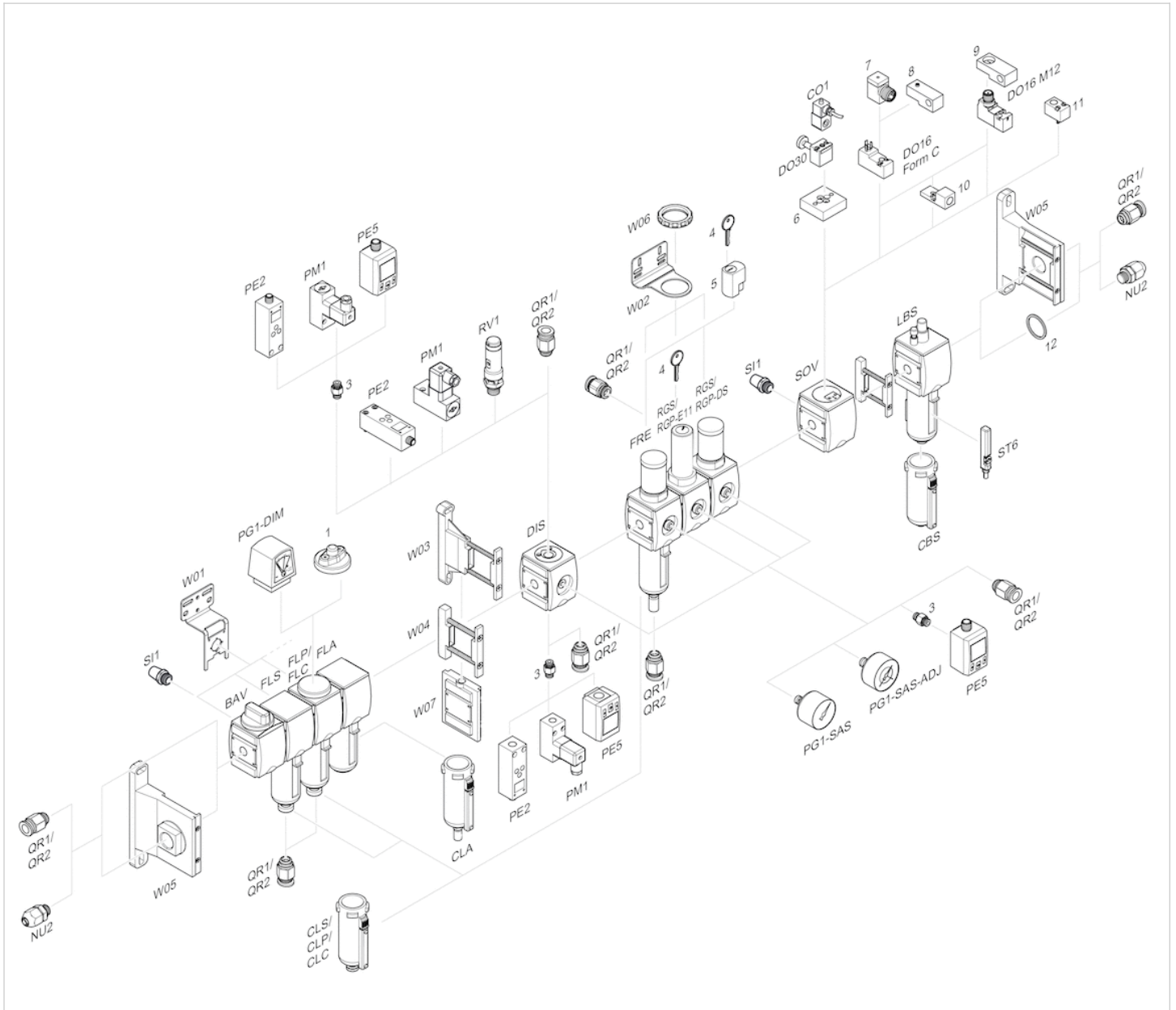

- 1 = contamination display
- 3 = Double nipple
- 4 = Key for E11 locking
- 5 = mortise lock
- 6 = Transition plate DO30
- 7 = Adapter, Series CON-VP
- 8 = Mounting aid DO16, form C
- 9 = Mounting aid DO16, M12
- 10 = Adapter for external pilot air
- 11 = Adapter pneumatic operation
- 12 = Sealing ring

Filter pressure regulator, Series AS2-FRE

- G 1/4 G 3/8
- filter porosity 5 µm
- lockable
- for padlocks
- suitable for ATEX

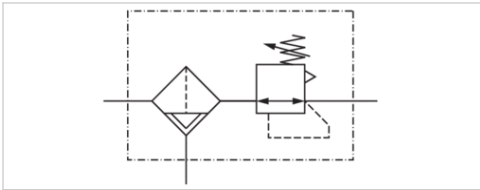

Version	1-part, Can be assembled into blocks
Parts	Filter pressure regulator
Mounting orientation	vertical
Certificates	suitable for ATEX
Working pressure min./max.	1.5 ... 16 bar
Ambient temperature min./max.	-10 ... 50 °C
Medium temperature min./max.	-10 ... 50 °C
Medium	Compressed air Neutral gases
Regulator type	Diaphragm-type pressure regulator
Regulator function	with relieving air exhaust
Adjustment range min./max.	See table below
Pressure supply	single
Filter reservoir volume	28 cm ³
Filter element	exchangeable
Weight	See table below

Technical data

Part No.	Port	filter porosity	Flow	Adjustment range min./max.
			Qn	
R412006175	G 1/4	5 µm	2100 l/min	0.5 ... 8 bar
R412006181	G 1/4	5 µm	2100 l/min	0.5 ... 8 bar
R412006193	G 1/4	5 µm	2100 l/min	0.5 ... 10 bar
R412006236	G 1/4	5 µm	2100 l/min	0.5 ... 16 bar
R412006176	G 1/4	5 µm	2100 l/min	0.5 ... 8 bar
R412006177	G 1/4	5 µm	2100 l/min	0.5 ... 8 bar
R412006182	G 1/4	5 µm	2100 l/min	0.5 ... 8 bar
R412006183	G 1/4	5 µm	2100 l/min	0.5 ... 8 bar
R412006194	G 1/4	5 µm	2100 l/min	0.5 ... 10 bar
R412006195	G 1/4	5 µm	2100 l/min	0.5 ... 10 bar
R412006237	G 1/4	5 µm	2100 l/min	0.5 ... 16 bar
R412006238	G 1/4	5 µm	2100 l/min	0.5 ... 16 bar
R412006184	G 3/8	5 µm	2600 l/min	0.5 ... 8 bar
R412006190	G 3/8	5 µm	2600 l/min	0.5 ... 8 bar
R412006191	G 3/8	5 µm	2600 l/min	0.5 ... 8 bar
R412006203	G 3/8	5 µm	2600 l/min	0.5 ... 10 bar
R412006239	G 3/8	5 µm	2600 l/min	0.5 ... 16 bar
R412006185	G 3/8	5 µm	2600 l/min	0.5 ... 8 bar

Part No.	Port	filter porosity	Flow	Adjustment range min./max.
			Qn	
R412006186	G 3/8	5 µm	2600 l/min	0.5 ... 8 bar
R412006192	G 3/8	5 µm	2600 l/min	0.5 ... 8 bar
R412006204	G 3/8	5 µm	2600 l/min	0.5 ... 10 bar
R412006205	G 3/8	5 µm	2600 l/min	0.5 ... 10 bar
R412006240	G 3/8	5 µm	2600 l/min	0.5 ... 16 bar
R412006241	G 3/8	5 µm	2600 l/min	0.5 ... 16 bar

Part No.	Condensate drain	Reservoir	Protective guard	Weight
R412006175	semi-automatic, open without pressure	Polycarbonate	Polyamide	0.304 kg
R412006181	semi-automatic, open without pressure	Die cast zinc	-	0.537 kg
R412006193	semi-automatic, open without pressure	Polycarbonate	Polyamide	0.304 kg
R412006236	semi-automatic, open without pressure	Polycarbonate	Polyamide	0.304 kg
R412006176	fully automatic, open without pressure	Polycarbonate	Polyamide	0.347 kg
R412006177	fully automatic, closed without pressure	Polycarbonate	Polyamide	0.347 kg
R412006182	fully automatic, open without pressure	Die cast zinc	-	0.66 kg
R412006183	fully automatic, closed without pressure	Die cast zinc	-	0.589 kg
R412006194	fully automatic, open without pressure	Polycarbonate	Polyamide	0.347 kg
R412006195	fully automatic, closed without pressure	Polycarbonate	Polyamide	0.347 kg
R412006237	fully automatic, open without pressure	Polycarbonate	Polyamide	0.347 kg
R412006238	fully automatic, closed without pressure	Polycarbonate	Polyamide	0.347 kg
R412006184	semi-automatic, open without pressure	Polycarbonate	Polyamide	0.347 kg
R412006190	semi-automatic, open without pressure	Die cast zinc	-	0.523 kg
R412006191	semi-automatic, open without pressure	Die cast zinc	-	0.655 kg
R412006203	semi-automatic, open without pressure	Polycarbonate	Polyamide	0.523 kg
R412006239	semi-automatic, open without pressure	Polycarbonate	Polyamide	0.523 kg
R412006185	fully automatic, open without pressure	Polycarbonate	Polyamide	0.347 kg
R412006186	fully automatic, closed without pressure	Polycarbonate	Polyamide	0.347 kg
R412006192	fully automatic, closed without pressure	Die cast zinc	-	0.575 kg
R412006204	fully automatic, open without pressure	Polycarbonate	Polyamide	0.655 kg
R412006205	fully automatic, closed without pressure	Polycarbonate	Polyamide	0.575 kg
R412006240	fully automatic, open without pressure	Polycarbonate	Polyamide	0.655 kg
R412006241	fully automatic, closed without pressure	Polycarbonate	Polyamide	0.575 kg

Part No.	Fig.
R412006175	Fig. 1
R412006181	Fig. 1
R412006193	Fig. 1
R412006236	Fig. 1
R412006176	Fig. 2
R412006177	Fig. 2
R412006182	Fig. 2
R412006183	Fig. 2
R412006194	Fig. 2
R412006195	Fig. 2
R412006237	Fig. 2
R412006238	Fig. 2
R412006184	Fig. 3

Part No.	Fig.
R412006190	Fig. 3
R412006191	Fig. 3
R412006203	Fig. 3
R412006239	Fig. 3
R412006185	Fig. 4
R412006186	Fig. 4
R412006192	Fig. 4
R412006204	Fig. 4
R412006205	Fig. 4
R412006240	Fig. 4
R412006241	Fig. 4

Nominal flow Q_n with secondary pressure $p_2 = 6$ bar at $\Delta p = 1$ bar

Order pressure gauge separately, Suitable for use in Ex zones 1, 2, 21, 22.

Technical information

The pressure dew point must be at least 15 °C under ambient and medium temperature and may not exceed 3 °C .

Note: Polycarbonate reservoirs are susceptible to solvents, supplementary information can be found at "Customer information".

Suitable for use in Ex zones 1, 2, 21, 22.

A change in the flow direction (from air supply on the left to air supply on the right) occurs by rotating installation by 180° about the vertical axis. Please see the operating instructions for further details.

Also suitable for separation of fluid oil or water due to the design.

Max. achievable compressed air class acc. to ISO 8573-1:2010 6 : 7 : -

Technical information

Material	
Housing	Polyamide
Front plate	Acrylonitrile butadiene styrene
Seals	Acrylonitrile butadiene rubber
Threaded bushing	Die cast zinc
Reservoir	Polycarbonate Die cast zinc
Protective guard	Polyamide
Filter insert	Polyethylene

Dimensions

Dimensions in mm, Fig. 1

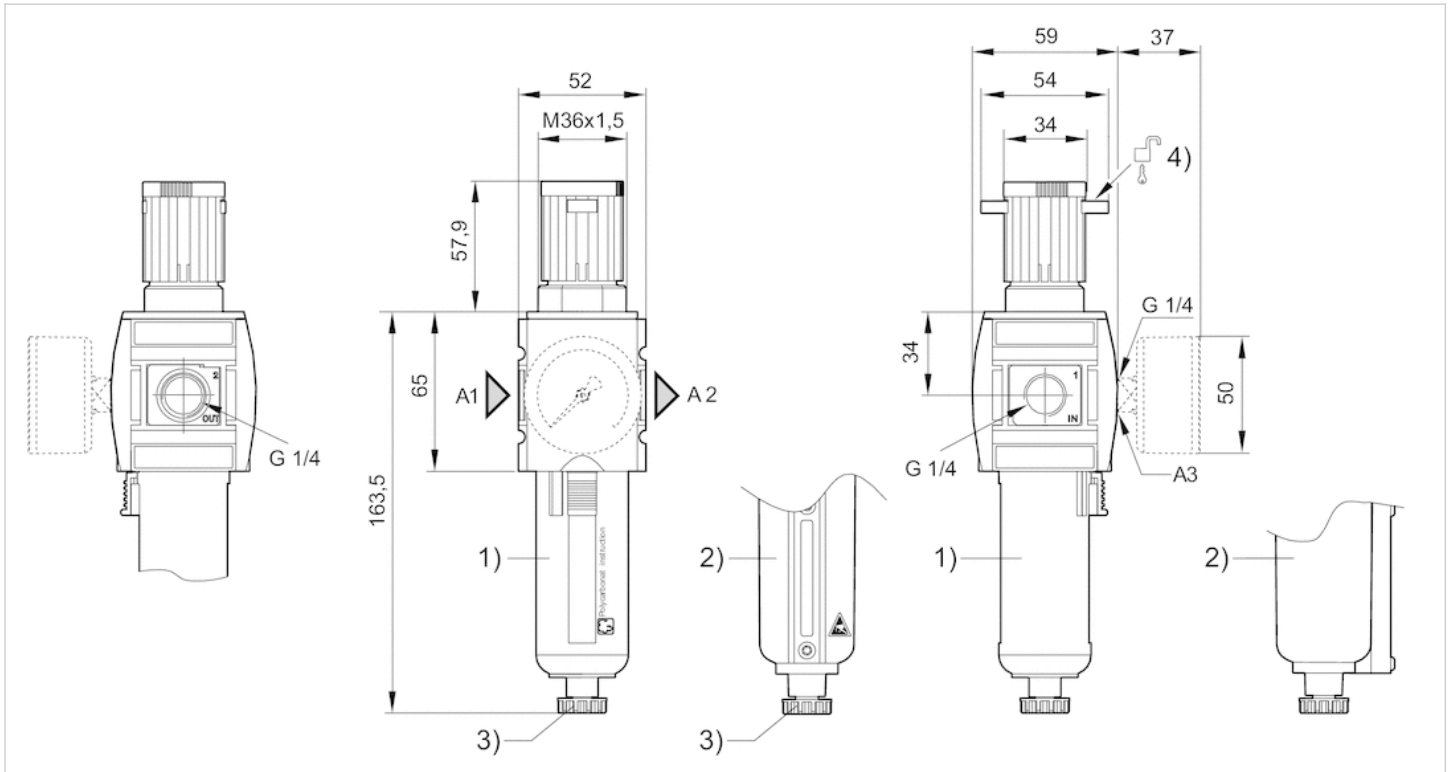

A1 = input

A2 = output

A3 = pressure gauge connection

1) Plastic reservoir and protective guard with window

2) Metal reservoir

3) Semi-automatic condensate drain

4) Mounting option for padlocks, max. shackle Ø 8

Dimensions in mm, Fig. 2

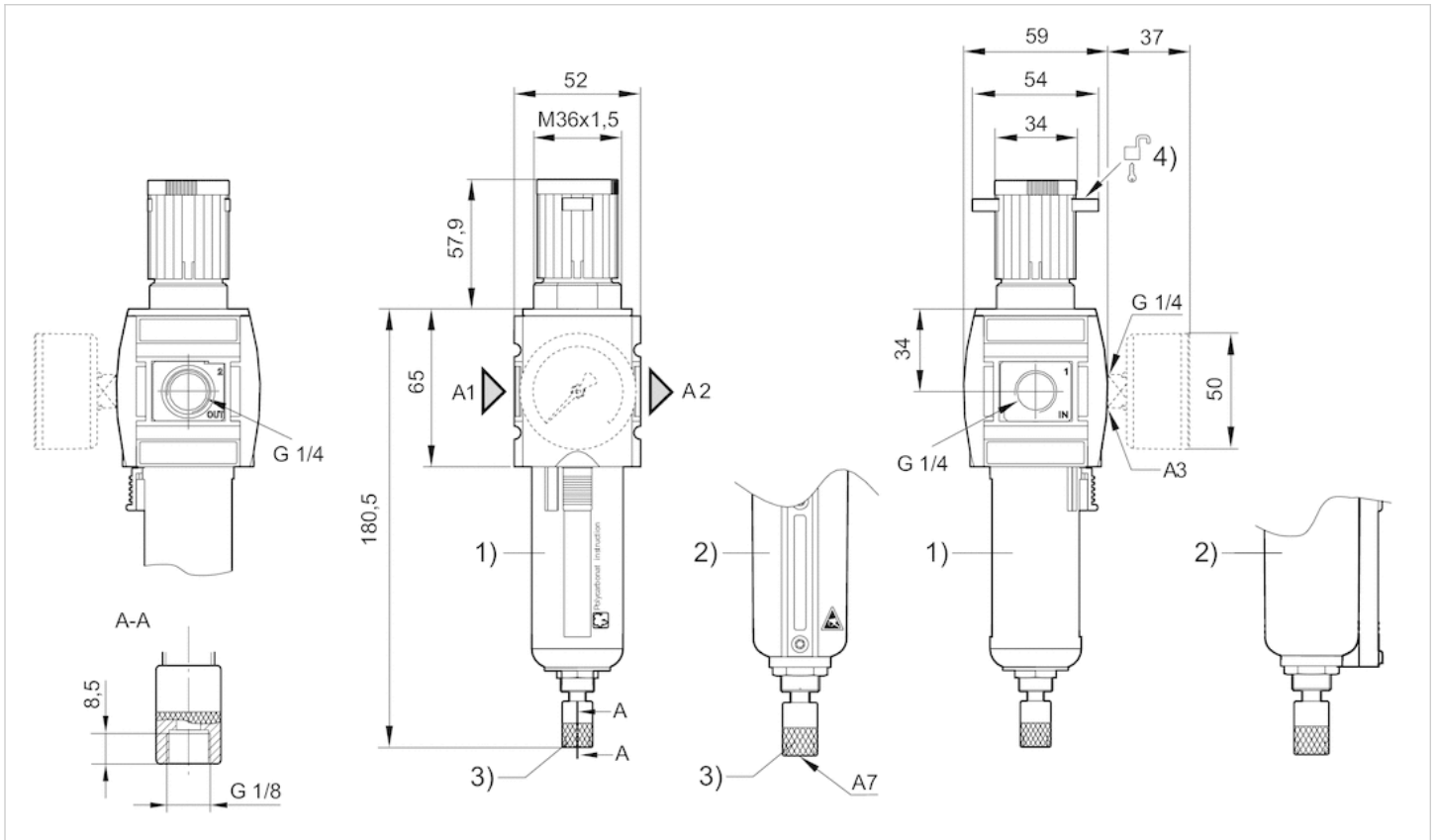

- A1 = input
- A2 = output
- A3 = pressure gauge connection
- A7 = condensate drain
- 1) Plastic reservoir and protective guard with window
- 2) Metal reservoir
- 3) Fully automatic condensate drain
- 4) Mounting option for padlocks, max. shackle Ø 8

Dimensions in mm, Fig. 3

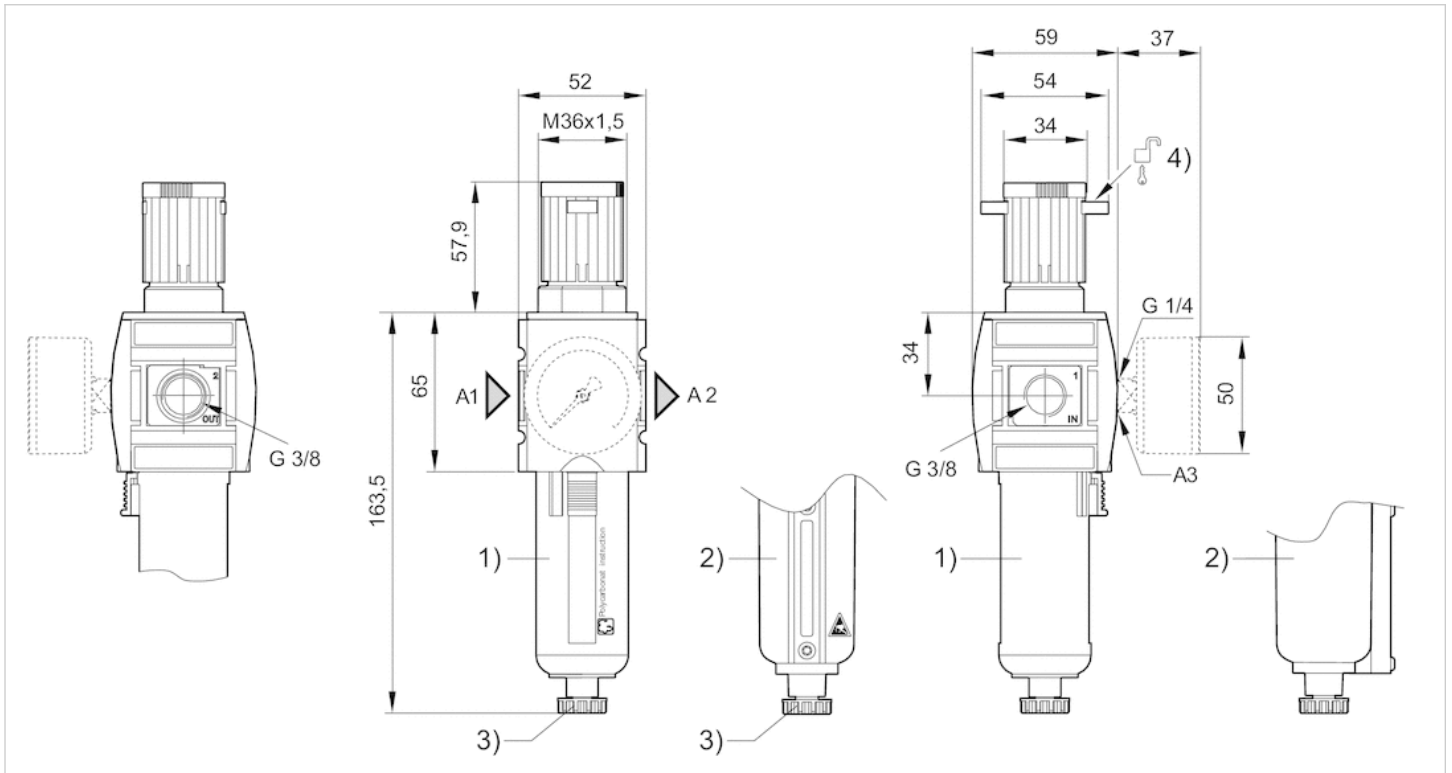

- A1 = input
- A2 = output
- A3 = pressure gauge connection
- 1) Plastic reservoir and protective guard with window
- 2) Metal reservoir
- 3) Semi-automatic condensate drain
- 4) Mounting option for padlocks, max. shackle Ø 8

Dimensions in mm, Fig. 4

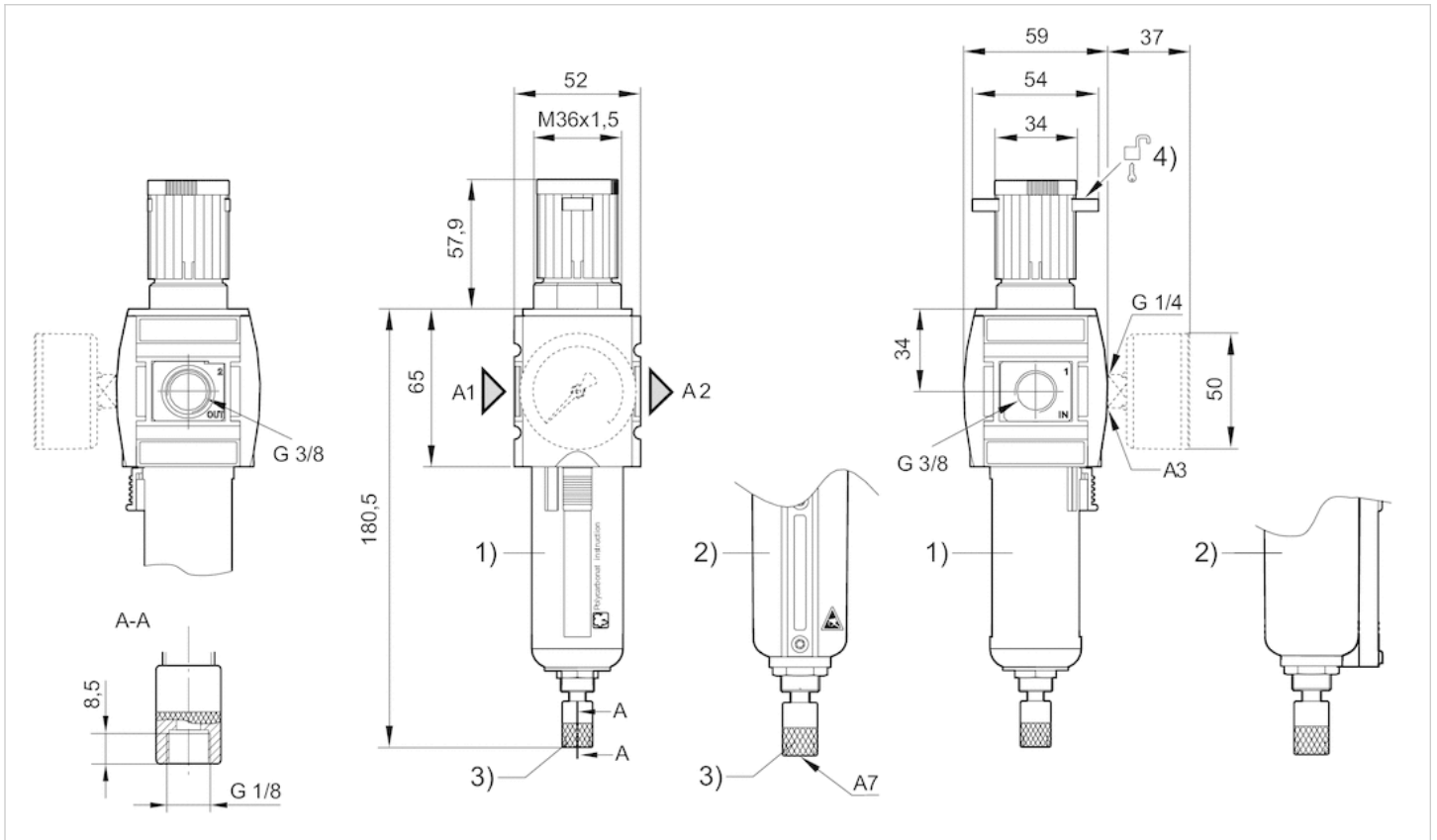

- A1 = input
- A2 = output
- A3 = pressure gauge connection
- A7 = condensate drain
- 1) Plastic reservoir and protective guard with window
- 2) Metal reservoir
- 3) Fully automatic condensate drain
- 4) Mounting option for padlocks, max. shackle Ø 8

Diagrams

Flow rate characteristic

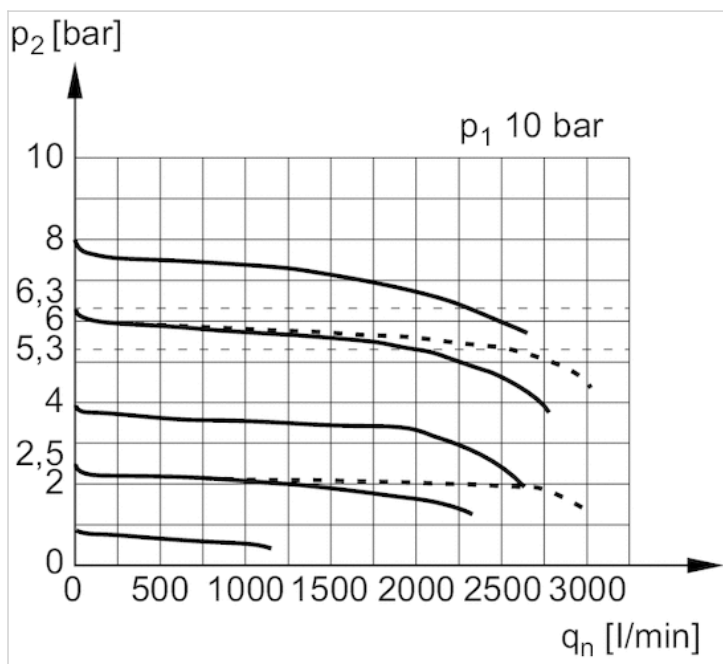

p_1 = Working pressure
 p_2 = Secondary pressure
 q_n = Nominal flow

Filter pressure regulator, Series AS2-FRE

- G 1/4 G 3/8
- filter porosity 5 µm
- lockable
- for padlocks
- with pressure gauge
- suitable for ATEX

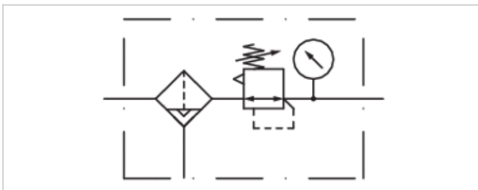

Version	1-part, Can be assembled into blocks
Parts	Filter pressure regulator
Mounting orientation	vertical
Certificates	suitable for ATEX
Working pressure min./max.	1.5 ... 16 bar
Ambient temperature min./max.	-10 ... 50 °C
Medium temperature min./max.	-10 ... 50 °C
Medium	Compressed air Neutral gases
Regulator type	Diaphragm-type pressure regulator
Regulator function	with relieving air exhaust
Adjustment range min./max.	See table below
Pressure supply	single
Filter reservoir volume	28 cm ³
Filter element	exchangeable
Weight	See table below

Technical data

Part No.	Port	filter porosity	Flow	Adjustment range min./max.
			Qn	
R412006200	G 1/4	5 µm	2100 l/min	0.5 ... 8 bar
R412006206	G 1/4	5 µm	2100 l/min	0.5 ... 8 bar
R412006196	G 1/4	5 µm	2100 l/min	0.5 ... 10 bar
R412006201	G 1/4	5 µm	2100 l/min	0.5 ... 8 bar
R412006202	G 1/4	5 µm	2100 l/min	0.5 ... 8 bar
R412006207	G 1/4	5 µm	2100 l/min	0.5 ... 8 bar
R412006208	G 1/4	5 µm	2100 l/min	0.5 ... 8 bar
R412006197	G 1/4	5 µm	2100 l/min	0.5 ... 10 bar
R412006198	G 1/4	5 µm	2100 l/min	0.5 ... 10 bar
R412006209	G 3/8	5 µm	2600 l/min	0.5 ... 8 bar
R412006215	G 3/8	5 µm	2600 l/min	0.5 ... 8 bar
R412006212	G 3/8	5 µm	2600 l/min	0.5 ... 10 bar
R412006210	G 3/8	5 µm	2600 l/min	0.5 ... 8 bar
R412006211	G 3/8	5 µm	2600 l/min	0.5 ... 8 bar
R412006216	G 3/8	5 µm	2600 l/min	0.5 ... 8 bar
R412006217	G 3/8	5 µm	2600 l/min	0.5 ... 8 bar
R412006213	G 3/8	5 µm	2600 l/min	0.5 ... 10 bar

Part No.	Port	filter porosity	Flow	Adjustment range min./max.
			Qn	
R412006214	G 3/8	5 µm	2600 l/min	0.5 ... 10 bar
R412026710	G 1/4	5 µm	2100 l/min	0.5 ... 8 bar

Part No.	Condensate drain	Pressure gauge	Reservoir
R412006200	semi-automatic, open without pressure	with pressure gauge	Polycarbonate
R412006206	semi-automatic, open without pressure	with pressure gauge	Die cast zinc
R412006196	semi-automatic, open without pressure	with pressure gauge	Polycarbonate
R412006201	fully automatic, open without pressure	with pressure gauge	Polycarbonate
R412006202	fully automatic, closed without pressure	with pressure gauge	Polycarbonate
R412006207	fully automatic, open without pressure	with pressure gauge	Die cast zinc
R412006208	fully automatic, closed without pressure	with pressure gauge	Die cast zinc
R412006197	fully automatic, open without pressure	with pressure gauge	Polycarbonate
R412006198	fully automatic, closed without pressure	with pressure gauge	Polycarbonate
R412006209	semi-automatic, open without pressure	with pressure gauge	Polycarbonate
R412006215	semi-automatic, open without pressure	with pressure gauge	Die cast zinc
R412006212	semi-automatic, open without pressure	with pressure gauge	Polycarbonate
R412006210	fully automatic, open without pressure	with pressure gauge	Polycarbonate
R412006211	fully automatic, closed without pressure	with pressure gauge	Polycarbonate
R412006216	fully automatic, open without pressure	with pressure gauge	Die cast zinc
R412006217	fully automatic, closed without pressure	with pressure gauge	Die cast zinc
R412006213	fully automatic, open without pressure	with pressure gauge	Polycarbonate
R412006214	fully automatic, closed without pressure	with pressure gauge	Polycarbonate
R412026710	semi-automatic, open without pressure	with pressure gauge	Polycarbonate

Part No.	Protective guard	Weight	Fig.	
R412006200	Polyamide	0.394 kg	Fig. 1	1)
R412006206	-	0.609 kg	Fig. 1	1)
R412006196	Polyamide	0.394 kg	Fig. 1	1)
R412006201	Polyamide	0.437 kg	Fig. 2	1)
R412006202	Polyamide	0.437 kg	Fig. 2	1)
R412006207	-	0.661 kg	Fig. 2	1)
R412006208	-	0.661 kg	Fig. 2	1)
R412006197	Polyamide	0.437 kg	Fig. 2	1)
R412006198	Polyamide	0.437 kg	Fig. 2	1)
R412006209	Polyamide	0.437 kg	Fig. 3	1)
R412006215	-	0.596 kg	Fig. 3	1)
R412006212	Polyamide	0.596 kg	Fig. 3	1)
R412006210	Polyamide	0.437 kg	Fig. 4	1)
R412006211	Polyamide	0.437 kg	Fig. 4	1)
R412006216	-	0.648 kg	Fig. 4	1)
R412006217	-	0.648 kg	Fig. 4	1)
R412006213	Polyamide	0.648 kg	Fig. 4	1)
R412006214	Polyamide	0.648 kg	Fig. 4	1)
R412026710	Polyamide	0.394 kg	Fig. 2	2)

Pressure gauge enclosed separately, Nominal flow Qn with secondary pressure p2 = 6 bar at Δp = 1 bar

1) Suitable for use in Ex zones 1, 2, 21, 22.

2) Suitable for use in Ex zones 1, 2, 21, 22., Safe rear exhaust in case of drop (removal) of pilot pressure

Technical information

The pressure dew point must be at least 15 °C under ambient and medium temperature and may not exceed 3 °C .

Note: Polycarbonate reservoirs are susceptible to solvents, supplementary information can be found at "Customer information".

Suitable for use in Ex zones 1, 2, 21, 22.

A change in the flow direction (from air supply on the left to air supply on the right) occurs by rotating installation by 180° about the vertical axis. Please see the operating instructions for further details.

Also suitable for separation of fluid oil or water due to the design.

Max. achievable compressed air class acc. to ISO 8573-1:2010 6 : 7 : -

Technical information

Material	
Housing	Polyamide
Front plate	Acrylonitrile butadiene styrene
Seals	Acrylonitrile butadiene rubber
Threaded bushing	Die cast zinc
Reservoir	Polycarbonate Die cast zinc
Protective guard	Polyamide
Filter insert	Polyethylene

Dimensions

Dimensions in mm, Fig. 1

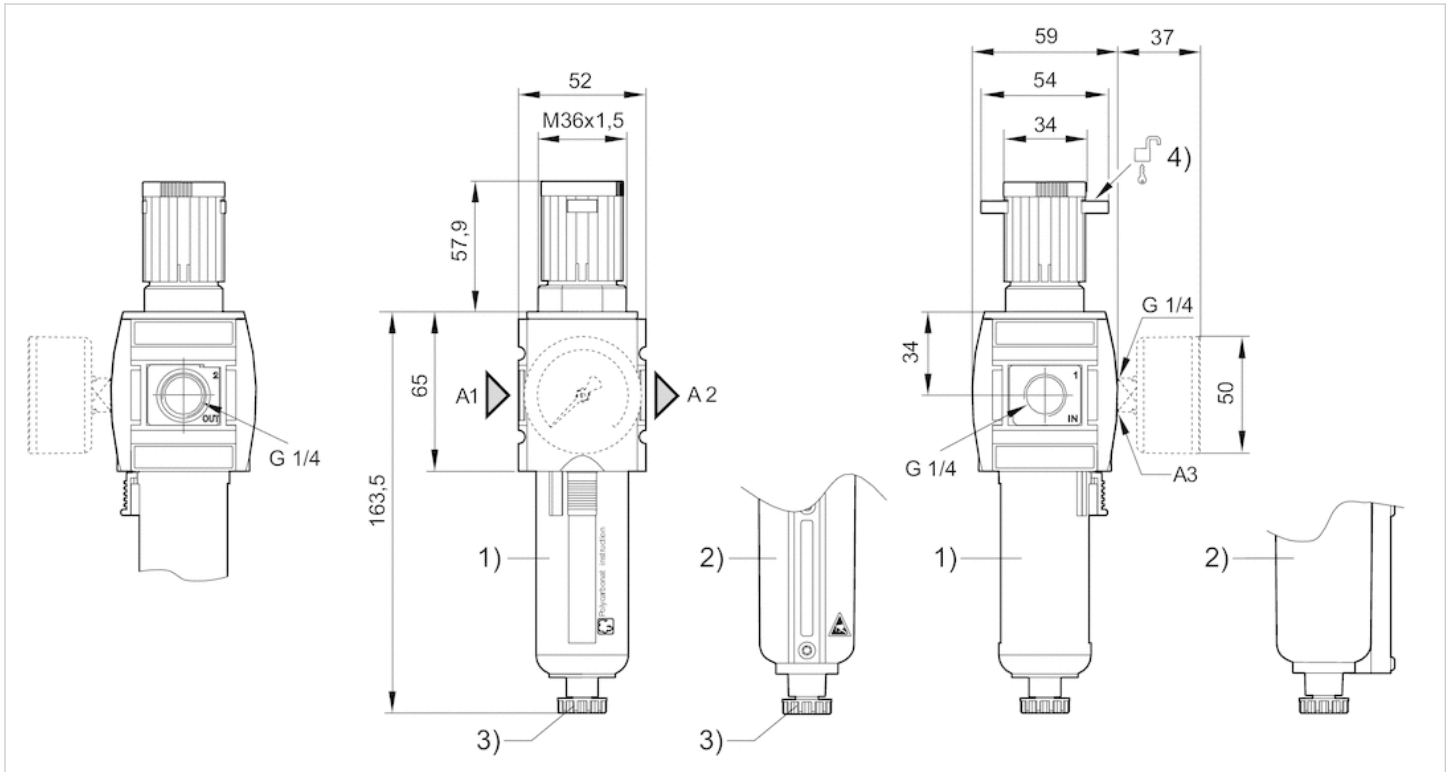

A1 = input

A2 = output

A3 = pressure gauge connection

1) Plastic reservoir and protective guard with window

2) Metal reservoir

3) Semi-automatic condensate drain

4) Mounting option for padlocks, max. shackle Ø 8

Dimensions in mm, Fig. 2

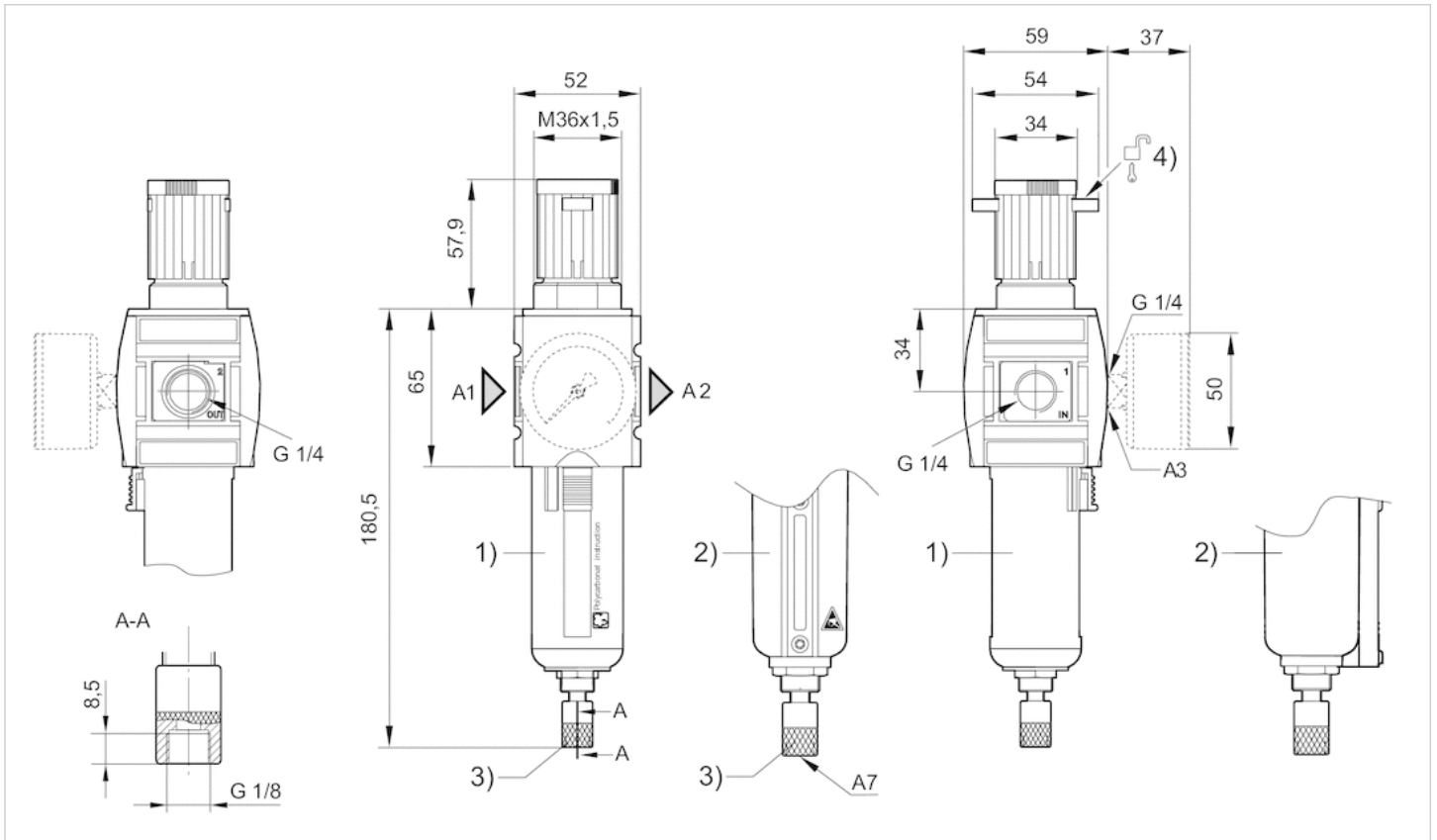

- A1 = input
- A2 = output
- A3 = pressure gauge connection
- A7 = condensate drain
- 1) Plastic reservoir and protective guard with window
- 2) Metal reservoir
- 3) Fully automatic condensate drain
- 4) Mounting option for padlocks, max. shackle Ø 8

Dimensions in mm, Fig. 3

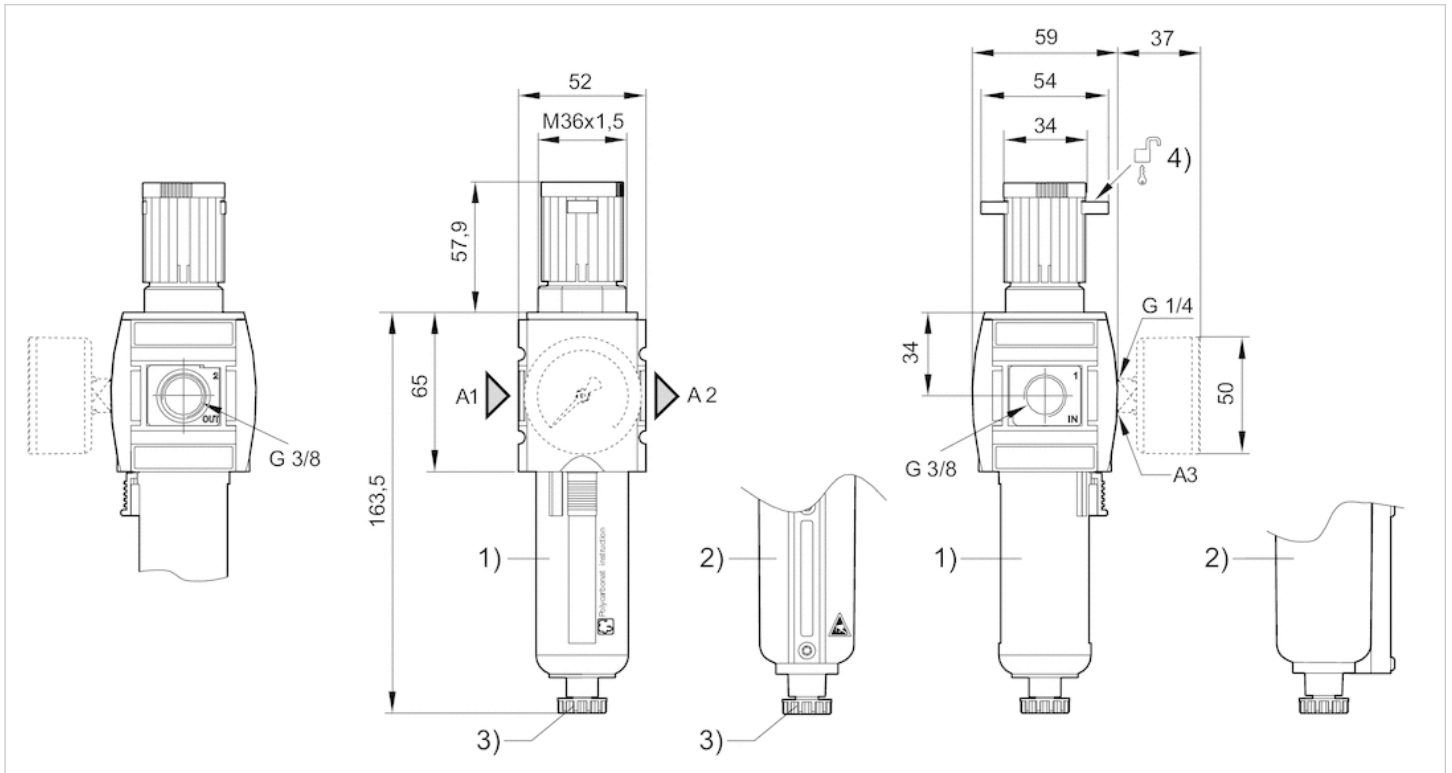

- A1 = input
- A2 = output
- A3 = pressure gauge connection
- 1) Plastic reservoir and protective guard with window
- 2) Metal reservoir
- 3) Semi-automatic condensate drain
- 4) Mounting option for padlocks, max. shackle Ø 8

Dimensions in mm, Fig. 4

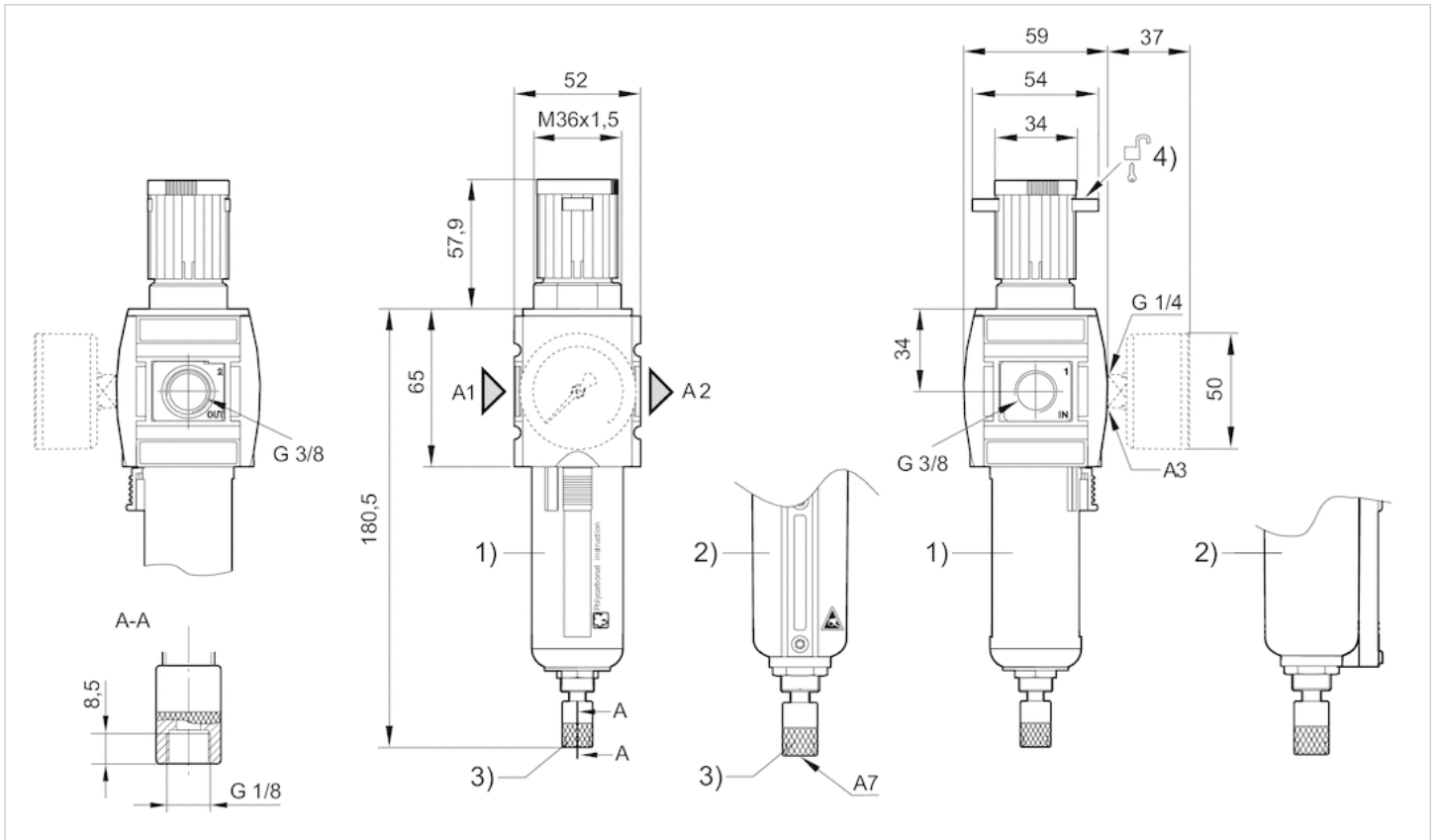

- A1 = input
- A2 = output
- A3 = pressure gauge connection
- A7 = condensate drain
- 1) Plastic reservoir and protective guard with window
- 2) Metal reservoir
- 3) Fully automatic condensate drain
- 4) Mounting option for padlocks, max. shackle Ø 8

Diagrams

Flow rate characteristic

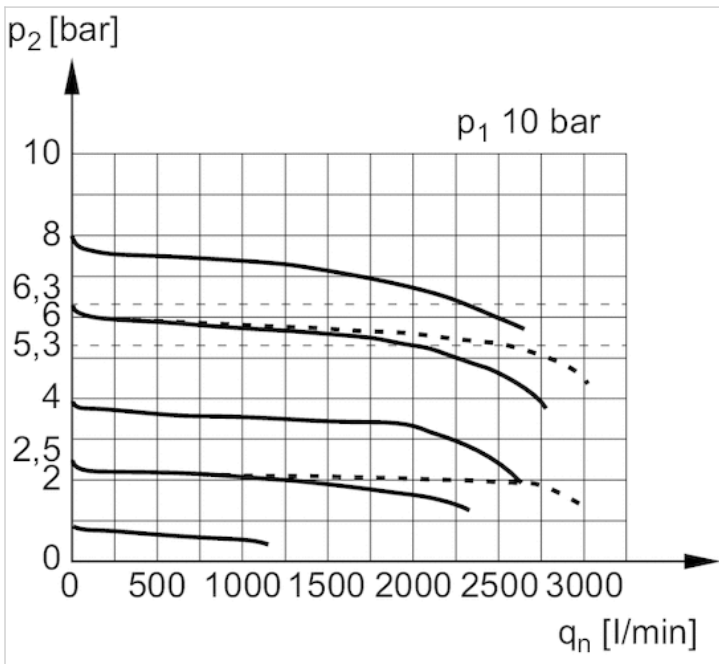

p_1 = Working pressure
 p_2 = Secondary pressure
 q_n = Nominal flow

Pressure characteristics curve, version with safe rear exhaust in case of drop (removal) of pilot pressure

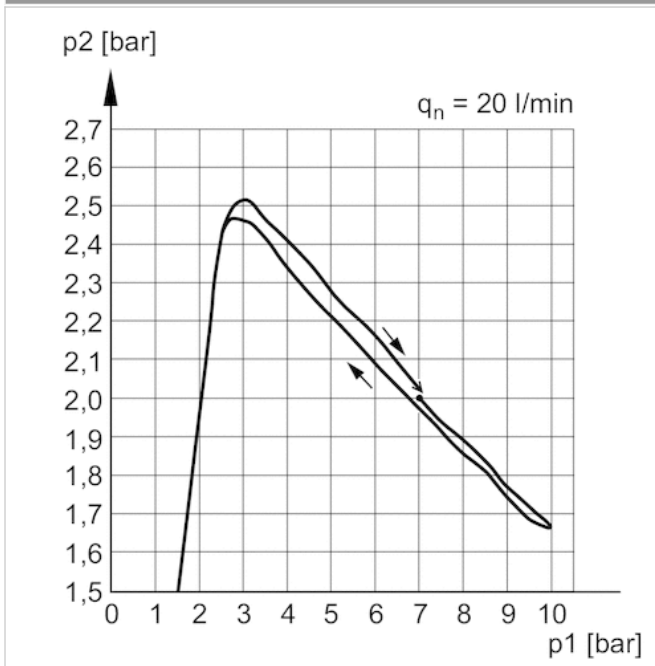

p_1 = Working pressure
 p_2 = Secondary pressure
 q_n = Nominal flow

Filter pressure regulator, Series AS2-FRE-...-E11

- G 1/4
- filter porosity 5 μm
- lockable
- with E11 locking

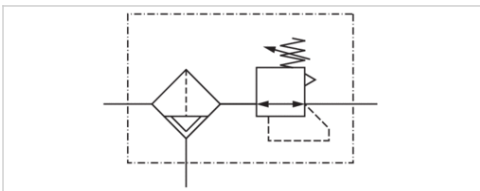

Version	1-part, Can be assembled into blocks
Parts	Filter pressure regulator
Mounting orientation	vertical
Working pressure min./max.	1.5 ... 16 bar
Ambient temperature min./max.	-10 ... 50 °C
Medium temperature min./max.	-10 ... 50 °C
Medium	Compressed air Neutral gases
Nominal flow Qn	2100 l/min
Regulator type	Diaphragm-type pressure regulator
Regulator function	with relieving air exhaust
Adjustment range min./max.	0.5 ... 10 bar
Pressure supply	single
Filter reservoir volume	28 cm ³
Filter element	exchangeable
Condensate drain	fully automatic, closed without pressure
Weight	0.347 kg

Technical data

Part No.	Port	filter porosity	Flow	Condensate drain
			Qn	
R412006189	G 1/4	5 μm	2100 l/min	fully automatic, closed without pressure

Order pressure gauge separately, Nominal flow Qn with secondary pressure p₂ = 6 bar at Δp = 1 bar

Technical information

The pressure dew point must be at least 15 °C under ambient and medium temperature and may not exceed 3 °C .

Note: Polycarbonate reservoirs are susceptible to solvents, supplementary information can be found at "Customer information". Suitable for use in Ex zones 1, 2, 21, 22.

A change in the flow direction (from air supply on the left to air supply on the right) occurs by rotating installation by 180° about the vertical axis. Please see the operating instructions for further details.

Also suitable for separation of fluid oil or water due to the design.

The E11 locking is delivered without a key (see accessories for keys).

Max. achievable compressed air class acc. to ISO 8573-1:2010 6 : 7 : -

Technical information

Material	
Housing	Polyamide
Front plate	Acrylonitrile butadiene styrene
Seals	Acrylonitrile butadiene rubber
Threaded bushing	Die cast zinc
Reservoir	Polycarbonate
Protective guard	Polyamide
Filter insert	Polyethylene

Dimensions

Dimensions

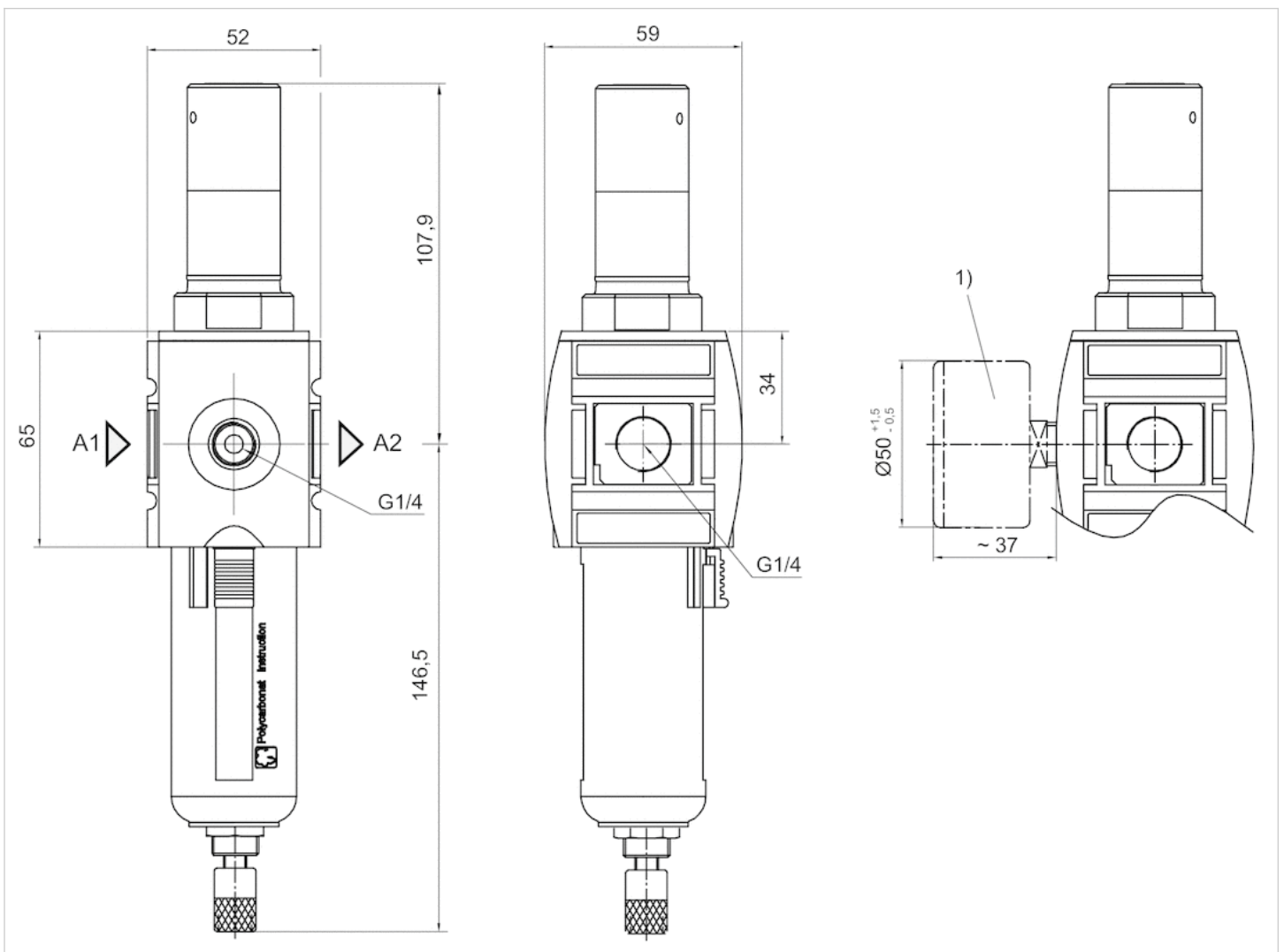

A1 = input

A2 = output

1) Order pressure gauge separately

Diagrams

Flow rate characteristic

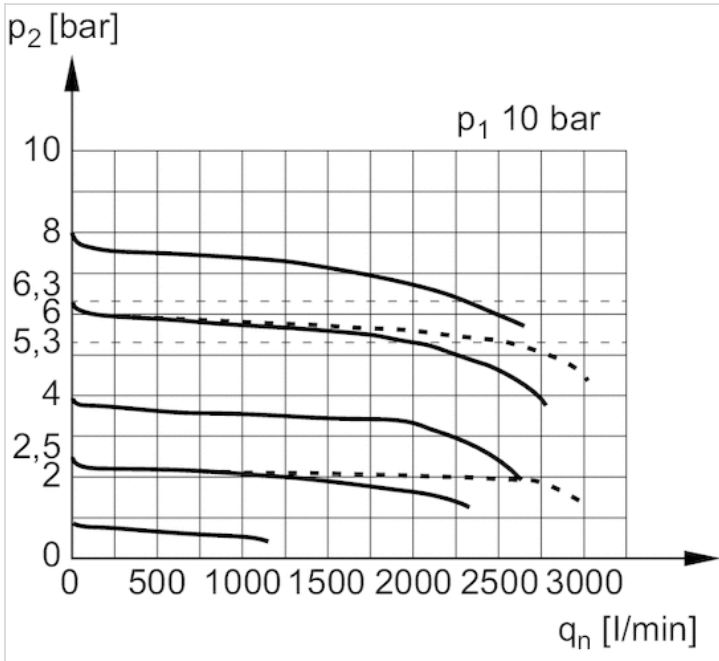

p_1 = Working pressure
 p_2 = Secondary pressure
 q_n = Nominal flow

Filter pressure regulator, Series AS2-FRE

- G 1/4 G 3/8
- filter porosity 25 µm
- lockable
- for padlocks
- suitable for ATEX

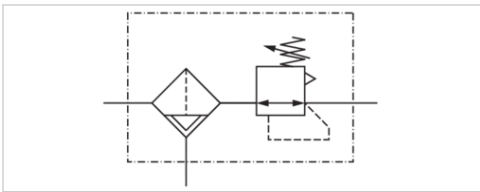

Version	1-part, Can be assembled into blocks
Parts	Filter pressure regulator
Mounting orientation	vertical
Certificates	suitable for ATEX
Working pressure min./max.	1.5 ... 16 bar
Ambient temperature min./max.	-10 ... 50 °C
Medium temperature min./max.	-10 ... 50 °C
Medium	Compressed air Neutral gases
Regulator type	Diaphragm-type pressure regulator
Regulator function	with relieving air exhaust
Adjustment range min./max.	See table below
Pressure supply	single
Filter reservoir volume	28 cm ³
Filter element	exchangeable
Weight	See table below

Technical data

Part No.	Port	filter porosity	Flow	Adjustment range min./max.
			Qn	
R412006180	G 1/4	25 µm	2100 l/min	0.5 ... 8 bar
R412006218	G 1/4	25 µm	2100 l/min	0.5 ... 10 bar
R412006219	G 1/4	25 µm	2100 l/min	0.5 ... 10 bar
R412006220	G 1/4	25 µm	2100 l/min	0 ... 10 bar
R412006221	G 3/8	25 µm	2600 l/min	0.5 ... 10 bar
R412006222	G 3/8	25 µm	2600 l/min	0.5 ... 10 bar
R412006223	G 3/8	25 µm	2600 l/min	0 ... 10 bar

Part No.	Condensate drain	Reservoir	Protective guard	Weight
R412006180	semi-automatic, open without pressure	Die cast zinc	-	0.537 kg
R412006218	semi-automatic, open without pressure	Polycarbonate	Polyamide	0.304 kg
R412006219	fully automatic, open without pressure	Polycarbonate	Polyamide	0.347 kg
R412006220	fully automatic, closed without pressure	Polycarbonate	Polyamide	0.347 kg
R412006221	semi-automatic, open without pressure	Polycarbonate	Polyamide	0.347 kg
R412006222	fully automatic, open without pressure	Polycarbonate	Polyamide	0.347 kg
R412006223	fully automatic, closed without pressure	Polycarbonate	Polyamide	0.347 kg

Part No.	Fig.
R412006180	Fig. 1
R412006218	Fig. 1
R412006219	Fig. 2
R412006220	Fig. 2
R412006221	Fig. 3
R412006222	Fig. 4
R412006223	Fig. 4

Nominal flow Q_n with secondary pressure $p_2 = 6$ bar at $\Delta p = 1$ bar

Order pressure gauge separately, Suitable for use in Ex zones 1, 2, 21, 22.

Technical information

The pressure dew point must be at least 15 °C under ambient and medium temperature and may not exceed 3 °C .

Note: Polycarbonate reservoirs are susceptible to solvents, supplementary information can be found at "Customer information".

Suitable for use in Ex zones 1, 2, 21, 22.

A change in the flow direction (from air supply on the left to air supply on the right) occurs by rotating installation by 180° about the vertical axis. Please see the operating instructions for further details.

Also suitable for separation of fluid oil or water due to the design.

Max. achievable compressed air class acc. to ISO 8573-1:2010 7 : 7 : -

Technical information

Material	
Housing	Polyamide
Front plate	Acrylonitrile butadiene styrene
Seals	Acrylonitrile butadiene rubber
Threaded bushing	Die cast zinc
Reservoir	Die cast zinc Polycarbonate
Protective guard	Polyamide
Filter insert	Polyethylene

Dimensions

Dimensions in mm, Fig. 1

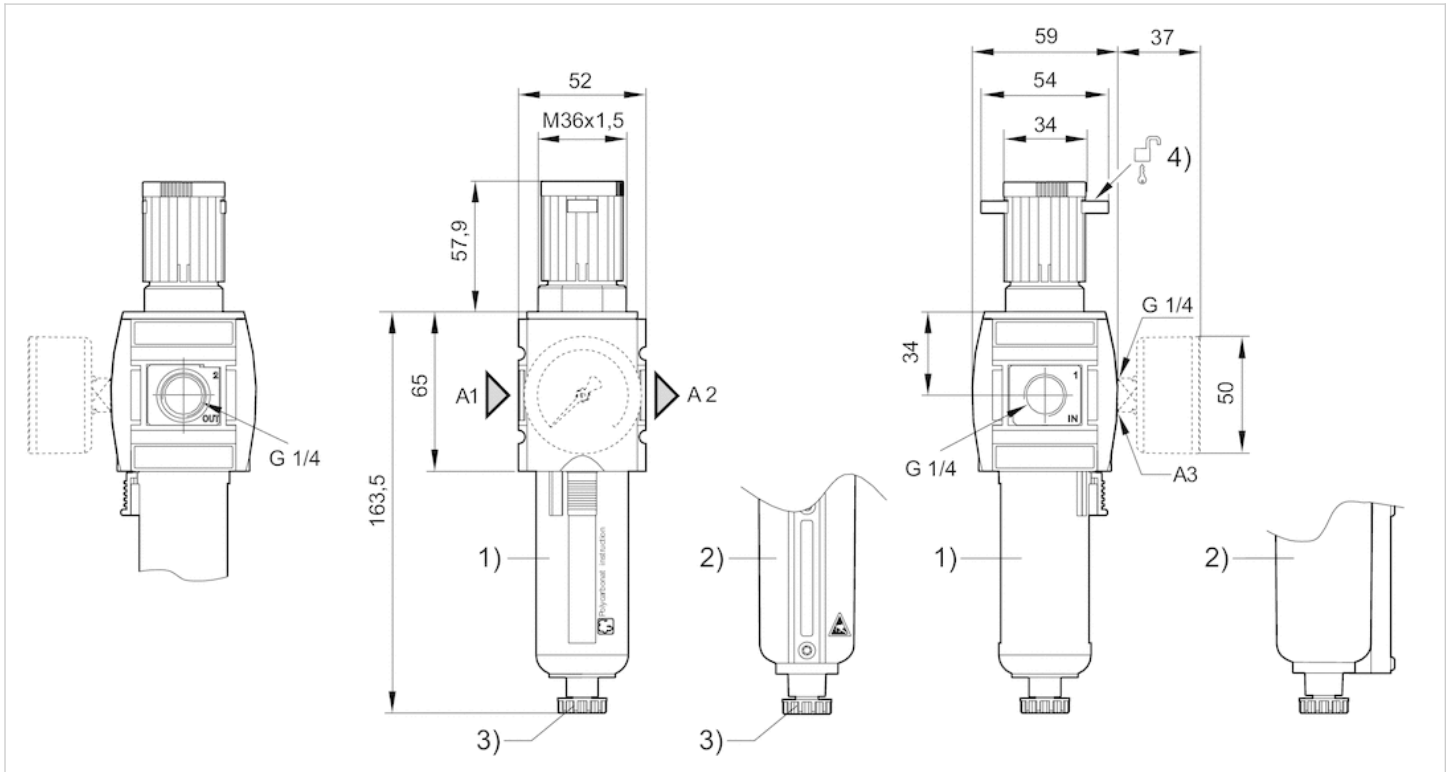

A1 = input

A2 = output

A3 = pressure gauge connection

1) Plastic reservoir and protective guard with window

2) Metal reservoir

3) Semi-automatic condensate drain

4) Mounting option for padlocks, max. shackle Ø 8

Dimensions in mm, Fig. 2

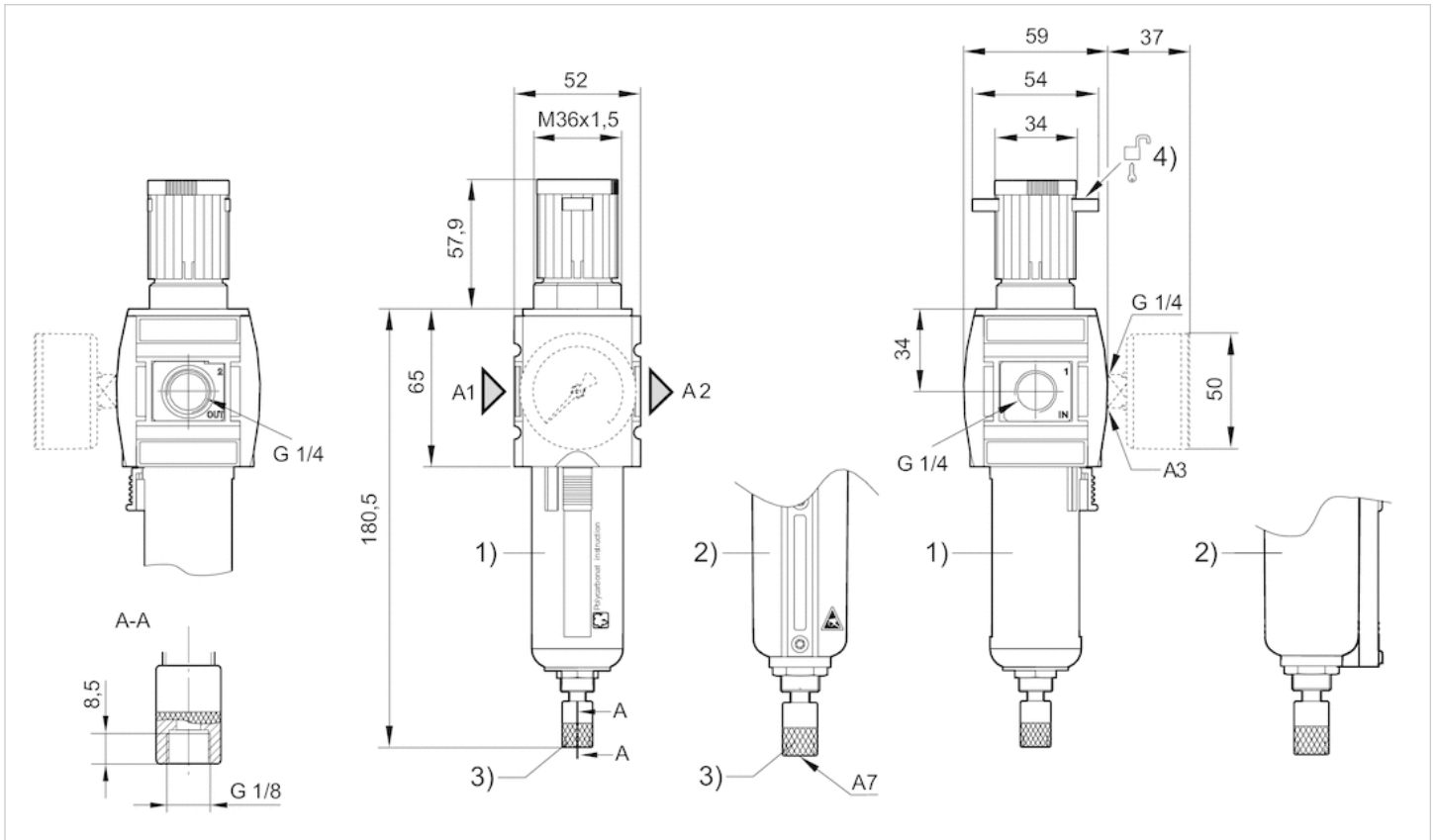

- A1 = input
- A2 = output
- A3 = pressure gauge connection
- A7 = condensate drain
- 1) Plastic reservoir and protective guard with window
- 2) Metal reservoir
- 3) Fully automatic condensate drain
- 4) Mounting option for padlocks, max. shackle Ø 8

Dimensions in mm, Fig. 3

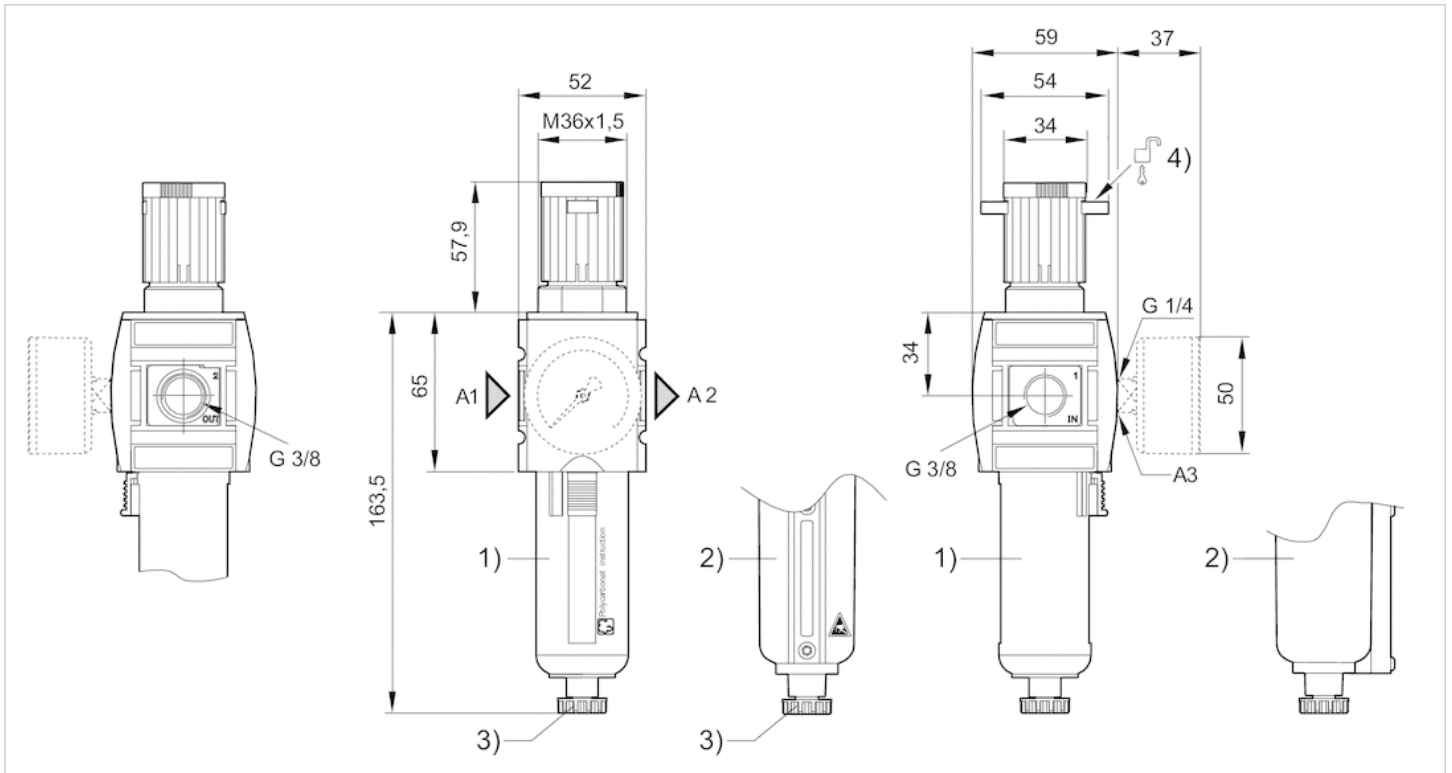

- A1 = input
- A2 = output
- A3 = pressure gauge connection
- 1) Plastic reservoir and protective guard with window
- 2) Metal reservoir
- 3) Semi-automatic condensate drain
- 4) Mounting option for padlocks, max. shackle Ø 8

Dimensions in mm, Fig. 4

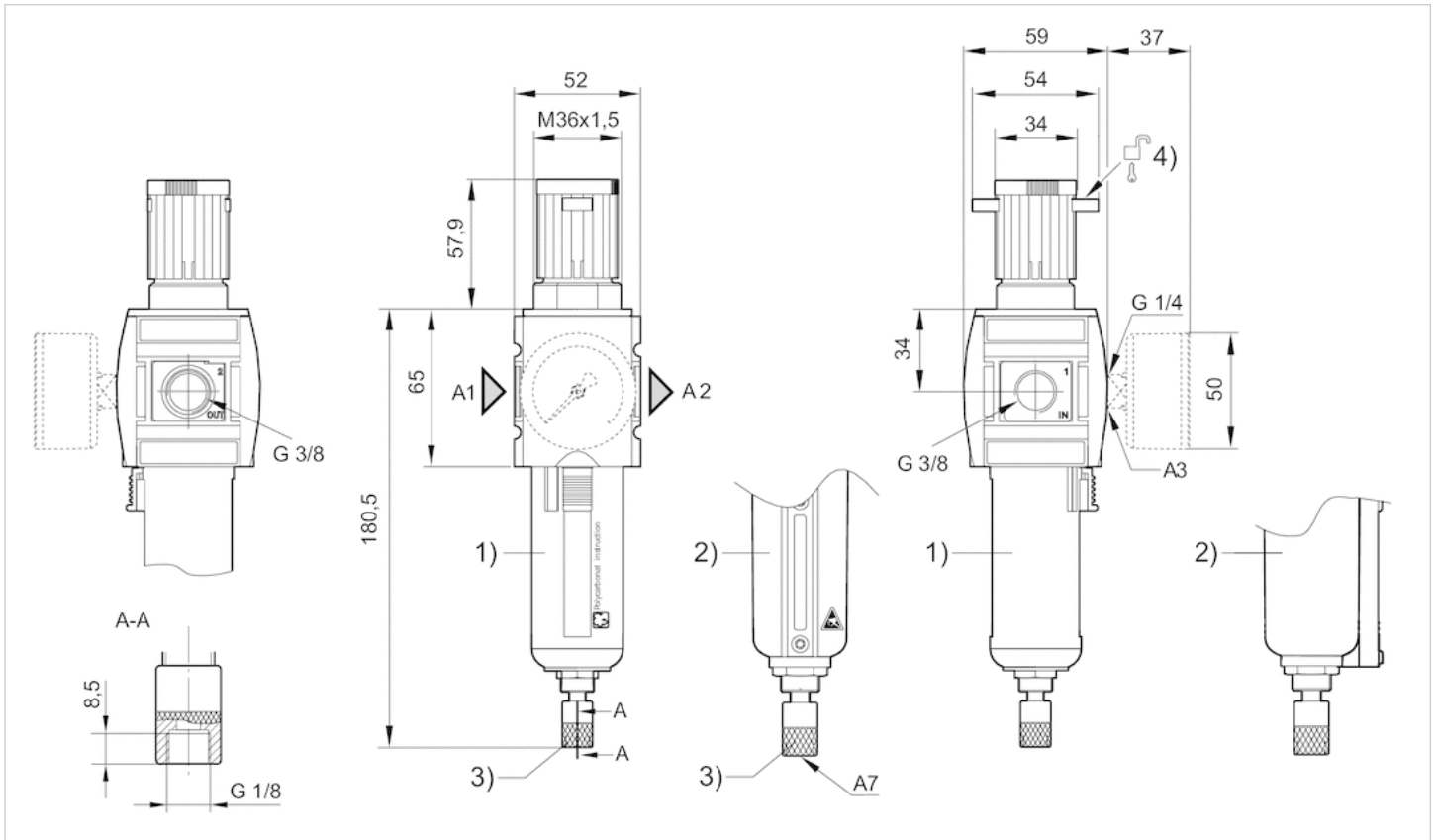

- A1 = input
- A2 = output
- A3 = pressure gauge connection
- A7 = condensate drain
- 1) Plastic reservoir and protective guard with window
- 2) Metal reservoir
- 3) Fully automatic condensate drain
- 4) Mounting option for padlocks, max. shackle Ø 8

Diagrams

Flow rate characteristic

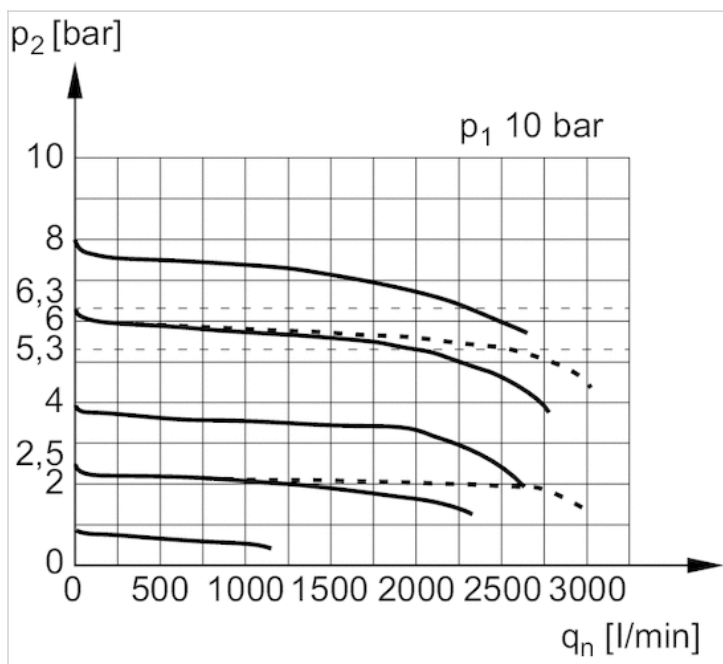

p_1 = Working pressure
 p_2 = Secondary pressure
 q_n = Nominal flow

Accessories overview

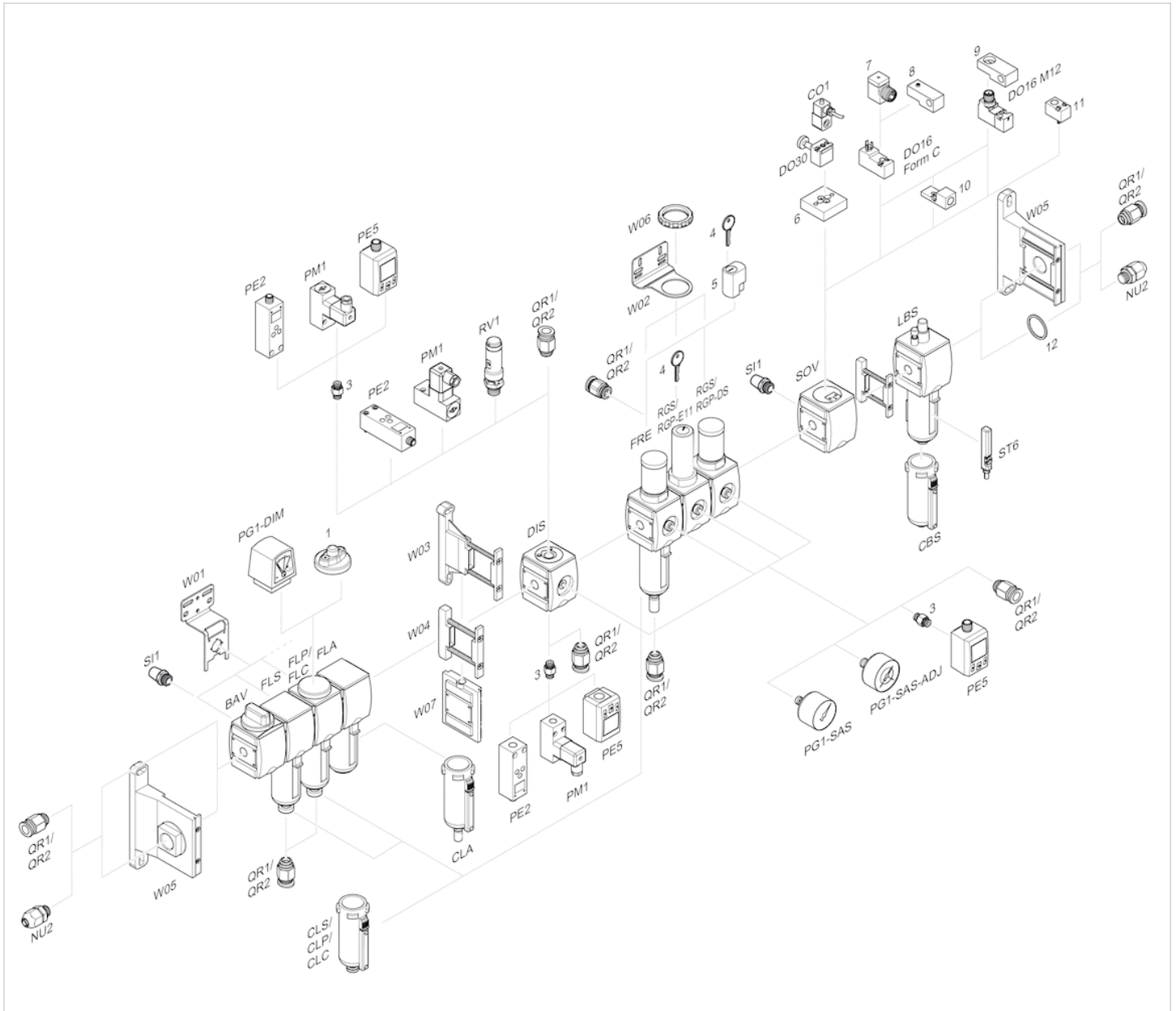

- 1 = contamination display
- 3 = Double nipple
- 4 = Key for E11 locking
- 5 = mortise lock
- 6 = Transition plate DO30
- 7 = Adapter, Series CON-VP
- 8 = Mounting aid DO16, form C
- 9 = Mounting aid DO16, M12
- 10 = Adapter for external pilot air
- 11 = Adapter pneumatic operation
- 12 = Sealing ring





Filter pressure regulator, Series AS2-FRE

- G 1/4 G 3/8
- filter porosity 40 µm
- lockable
- for padlocks
- with pressure gauge
- suitable for ATEX



Version	1-part, Can be assembled into blocks
Parts	Filter pressure regulator
Mounting orientation	vertical
Certificates	suitable for ATEX
Working pressure min./max.	See table below
Ambient temperature min./max.	-10 ... 50 °C
Medium temperature min./max.	-10 ... 50 °C
Medium	Compressed air Neutral gases
Max. particle size	40 µm
Regulator type	Diaphragm-type pressure regulator
Regulator function	with relieving air exhaust
Adjustment range min./max.	0.5 ... 8 bar
Pressure supply	single
Filter reservoir volume	28 cm ³
Filter element	exchangeable
Weight	See table below

Technical data

Part No.		—	Port	filter porosity	Flow	Working pressure min./max.
					Qn	
R412006199		—	G 1/4	40 µm	2100 l/min	0 ... 16 bar
R412006224			G 3/8	40 µm	2600 l/min	1.5 ... 16 bar

Part No.	Condensate drain	Pressure gauge	Weight	Fig.
R412006199	fully automatic, open without pressure	with pressure gauge	0.661 kg	Fig. 1
R412006224	semi-automatic, open without pressure	with pressure gauge	0.394 kg	Fig. 2

Part No.	Part No.
R412006199	1)
R412006224	2)

Nominal flow Qn with secondary pressure p₂ = 6 bar at Δp = 1 bar

- 1) Order pressure gauge separately, Suitable for use in Ex zones 1, 2, 21, 22.
- 2) Pressure gauge enclosed separately, Suitable for use in Ex zones 1, 2, 21, 22.

Technical information

The pressure dew point must be at least 15 °C under ambient and medium temperature and may not exceed 3 °C .

Note: Polycarbonate reservoirs are susceptible to solvents, supplementary information can be found at "Customer information".

Suitable for use in Ex zones 1, 2, 21, 22.

A change in the flow direction (from air supply on the left to air supply on the right) occurs by rotating installation by 180° about the vertical axis. Please see the operating instructions for further details.

Also suitable for separation of fluid oil or water due to the design.

Max. achievable compressed air class acc. to ISO 8573-1:2010 7 : 7 : -

Technical information

Material	
Housing	Polyamide
Front plate	Acrylonitrile butadiene styrene
Seals	Acrylonitrile butadiene rubber
Threaded bushing	Die cast zinc
Reservoir	Polycarbonate
Protective guard	Polyamide
Filter insert	Polyethylene

Dimensions

Dimensions in mm, Fig. 1

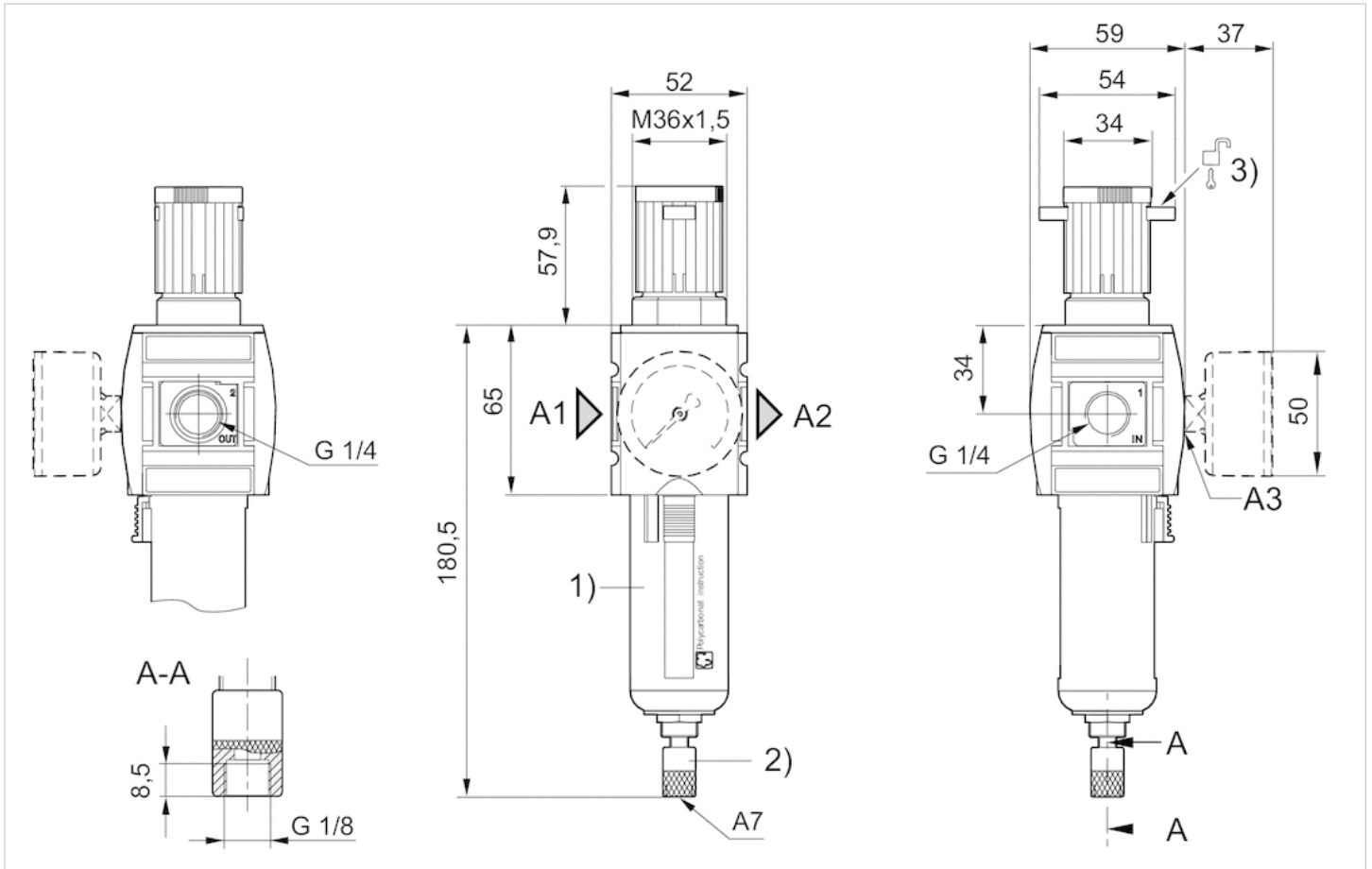

A1 = input

A2 = output

A3 = pressure gauge connection

A7 = condensate drain

1) Plastic reservoir and protective guard with window

2) Fully automatic condensate drain

3) Mounting option for padlocks, max. shackle \varnothing 8

Order pressure gauge separately

Dimensions in mm, Fig. 2

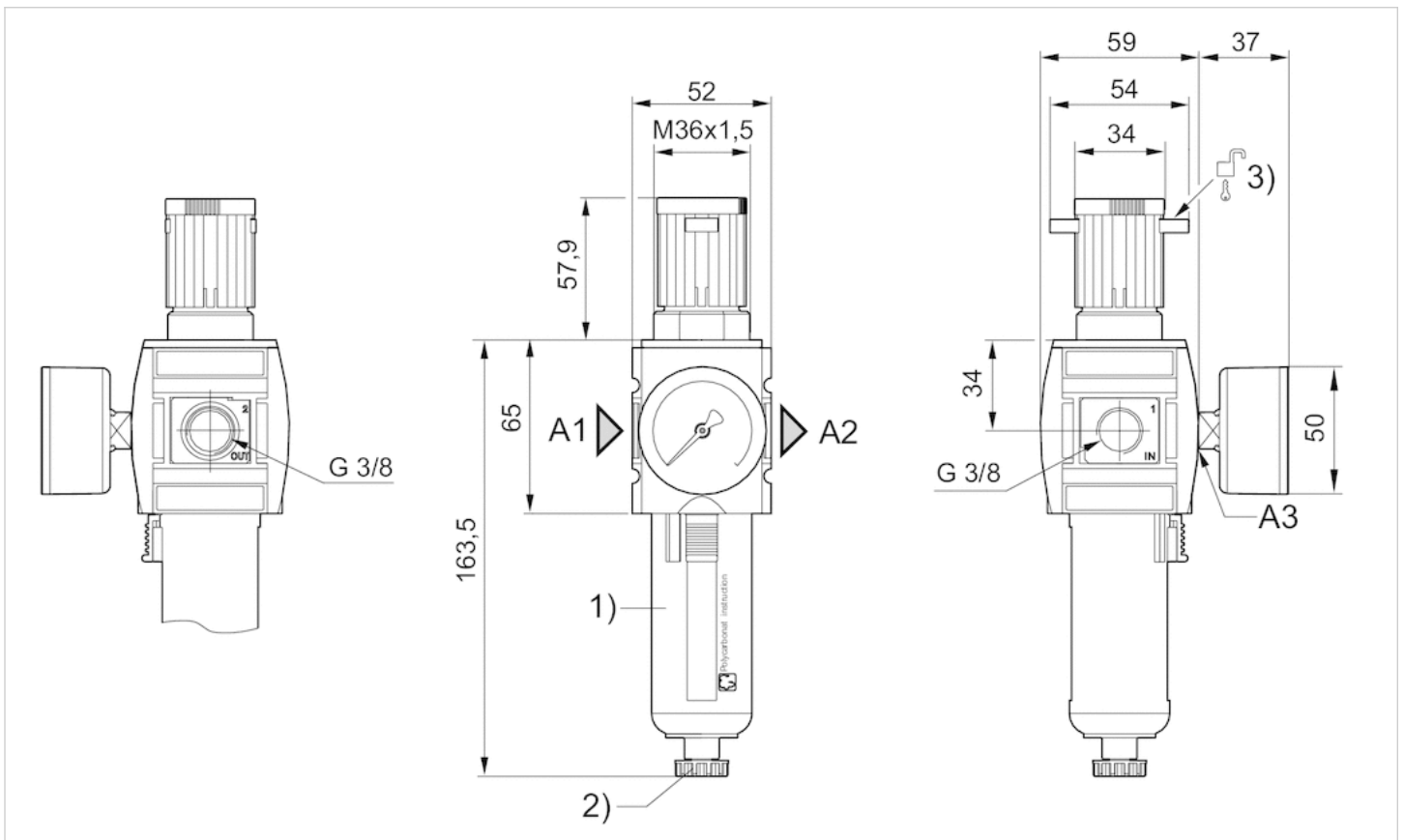

A1 = input

A2 = output

A3 = pressure gauge connection

1) Plastic reservoir and protective guard with window

2) Semi-automatic condensate drain

3) Mounting option for padlocks, max. shackle Ø 8

Pressure gauge enclosed separately

Diagrams

Flow rate characteristic

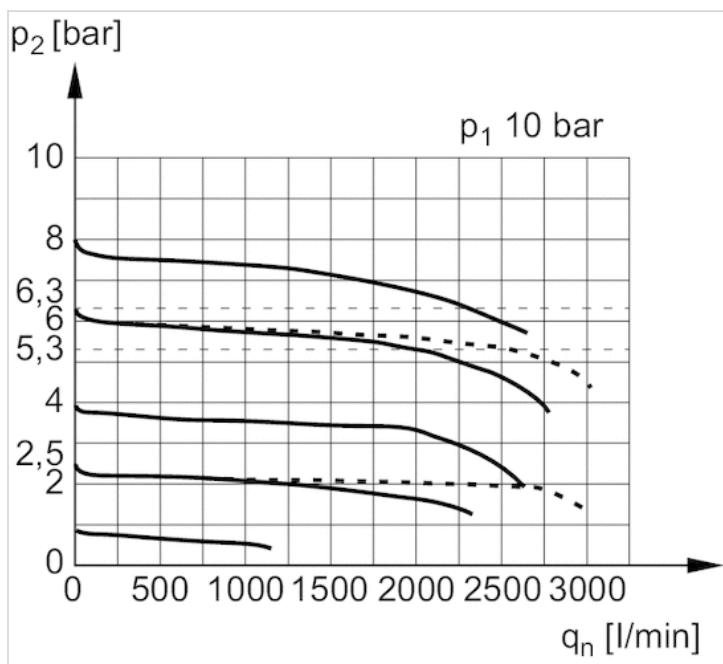

p_1 = Working pressure
 p_2 = Secondary pressure
 q_n = Nominal flow

Accessories overview

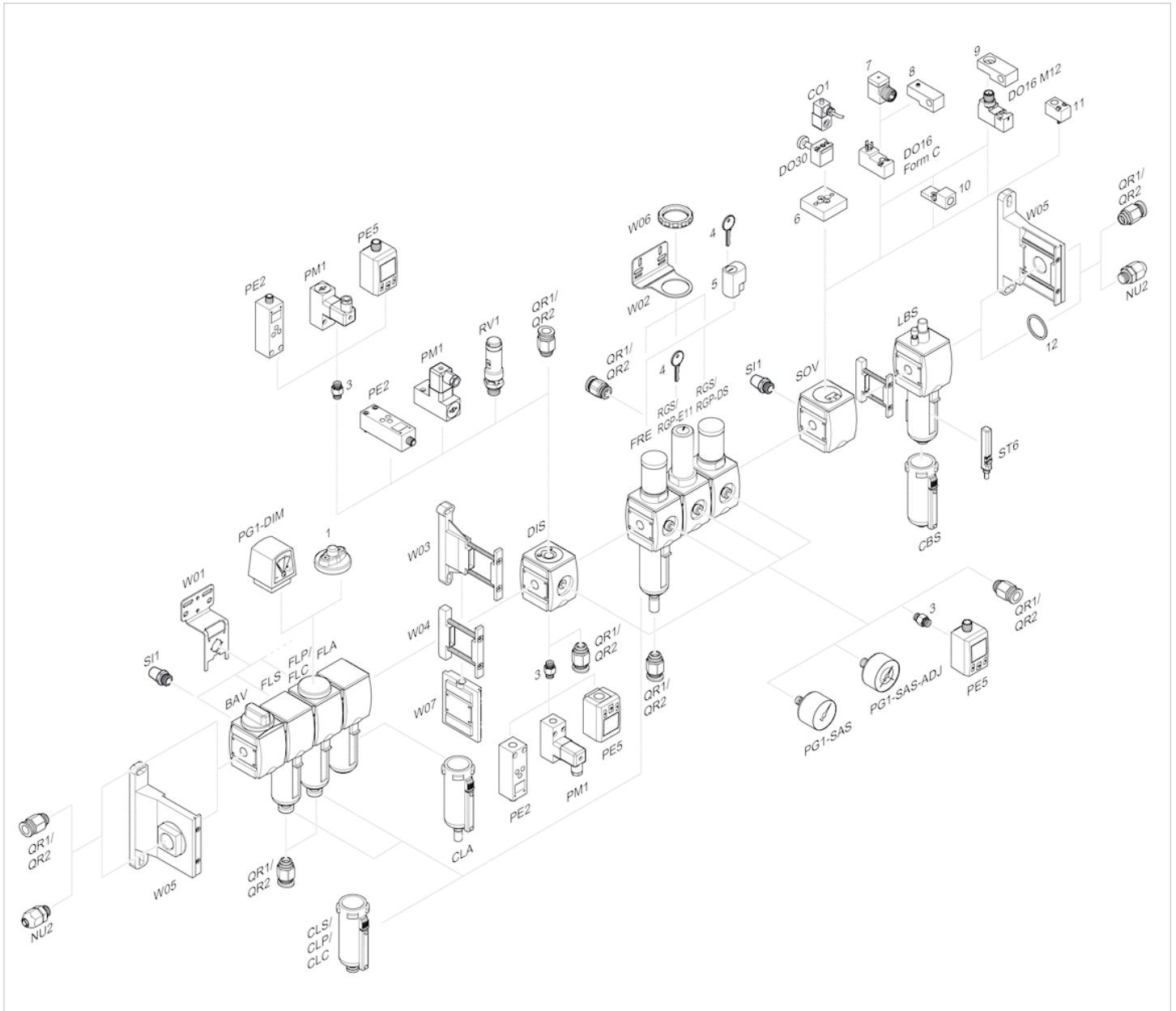

- 1 = contamination display
- 3 = Double nipple
- 4 = Key for E11 locking
- 5 = mortise lock
- 6 = Transition plate DO30
- 7 = Adapter, Series CON-VP
- 8 = Mounting aid DO16, form C
- 9 = Mounting aid DO16, M12
- 10 = Adapter for external pilot air
- 11 = Adapter pneumatic operation
- 12 = Sealing ring

Filter pressure regulator, Series AS2-FRE-...-E11

- G 1/4
- filter porosity 40 µm
- lockable
- with E11 locking

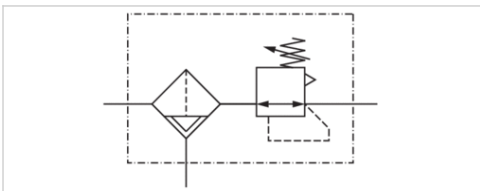

Version	1-part, Can be assembled into blocks
Parts	Filter pressure regulator
Mounting orientation	vertical
Working pressure min./max.	1.5 ... 16 bar
Ambient temperature min./max.	-10 ... 50 °C
Medium temperature min./max.	-10 ... 50 °C
Medium	Compressed air Neutral gases
Nominal flow Qn	2100 l/min
Regulator type	Diaphragm-type pressure regulator
Regulator function	with relieving air exhaust
Adjustment range min./max.	0.5 ... 10 bar
Pressure supply	single
Filter reservoir volume	28 cm ³
Filter element	exchangeable
Condensate drain	fully automatic, closed without pressure
Weight	0.347 kg

Technical data

Part No.	Port	filter porosity	Flow	Condensate drain
			Qn	
R412006188	G 1/4	40 µm	2100 l/min	fully automatic, closed without pressure

Order pressure gauge separately, Nominal flow Qn with secondary pressure p₂ = 6 bar at Δp = 1 bar

Technical information

The pressure dew point must be at least 15 °C under ambient and medium temperature and may not exceed 3 °C .

Note: Polycarbonate reservoirs are susceptible to solvents, supplementary information can be found at "Customer information".

Suitable for use in Ex zones 1, 2, 21, 22.

A change in the flow direction (from air supply on the left to air supply on the right) occurs by rotating installation by 180° about the vertical axis. Please see the operating instructions for further details.

Also suitable for separation of fluid oil or water due to the design.

The E11 locking is delivered without a key (see accessories for keys).

Max. achievable compressed air class acc. to ISO 8573-1:2010 7 : 7 : -

Technical information

Material	
Housing	Polyamide
Front plate	Acrylonitrile butadiene styrene
Seals	Acrylonitrile butadiene rubber
Threaded bushing	Die cast zinc
Reservoir	Polycarbonate
Protective guard	Polyamide
Filter insert	Polyethylene

Dimensions

Dimensions

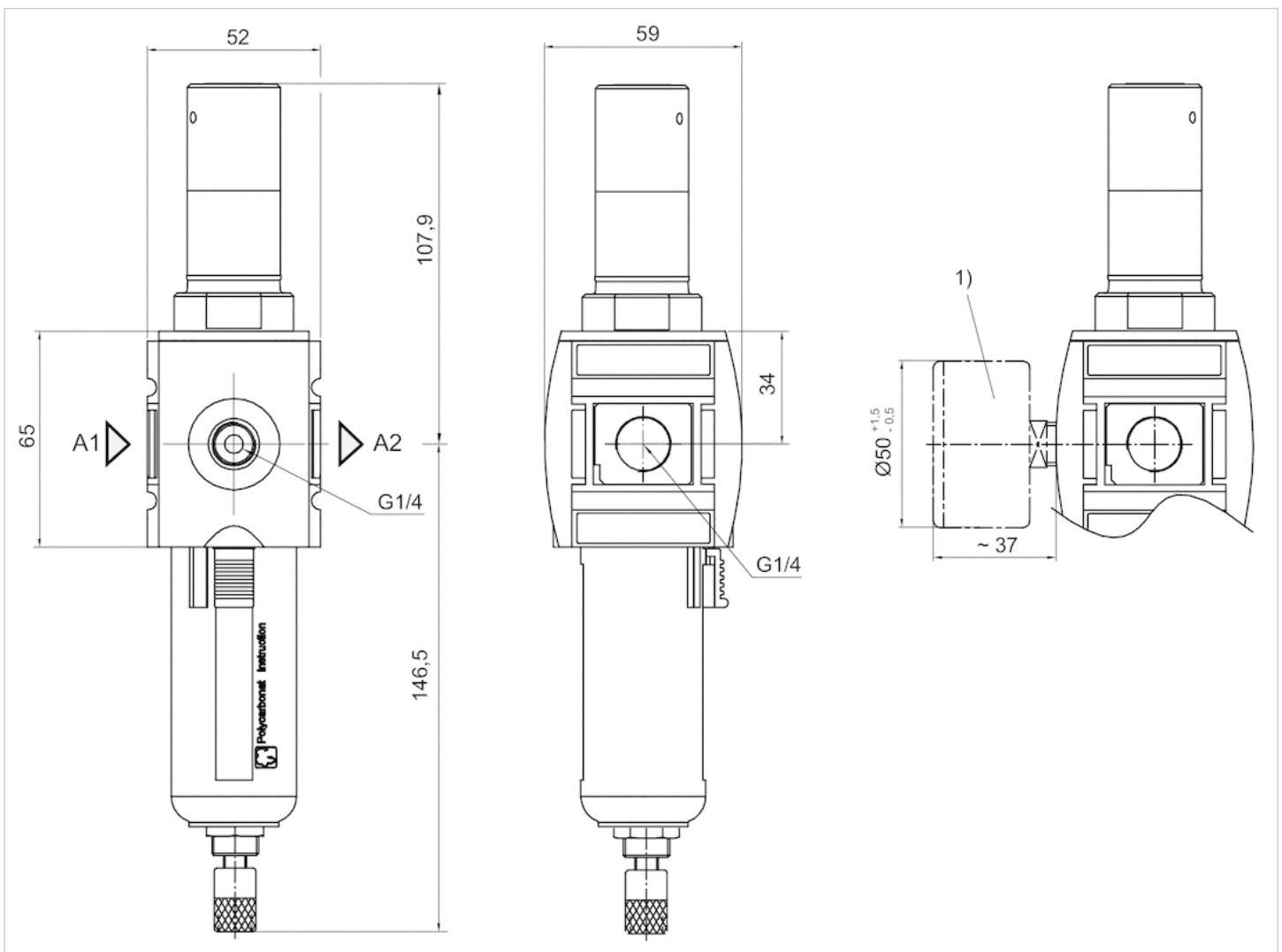

A1 = input

A2 = output

1) Order pressure gauge separately

Diagrams

Flow rate characteristic

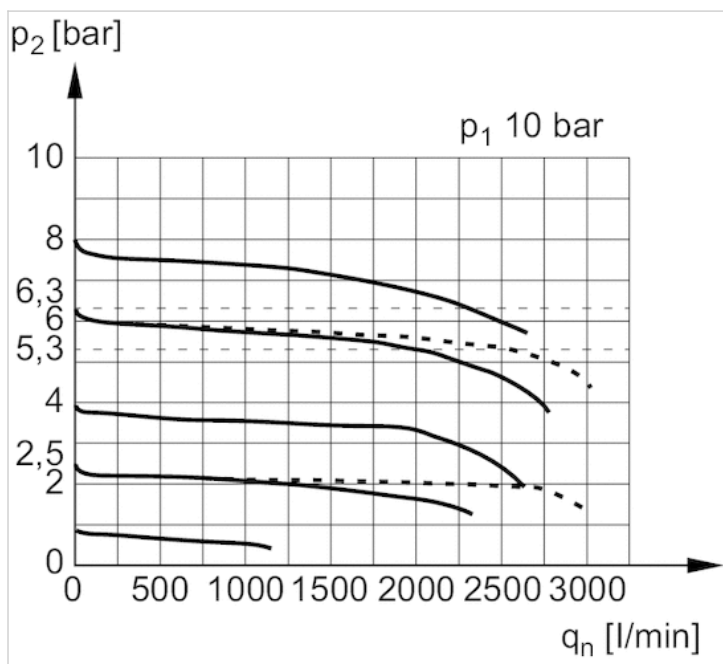

p_1 = Working pressure
 p_2 = Secondary pressure
 q_n = Nominal flow

Accessories overview

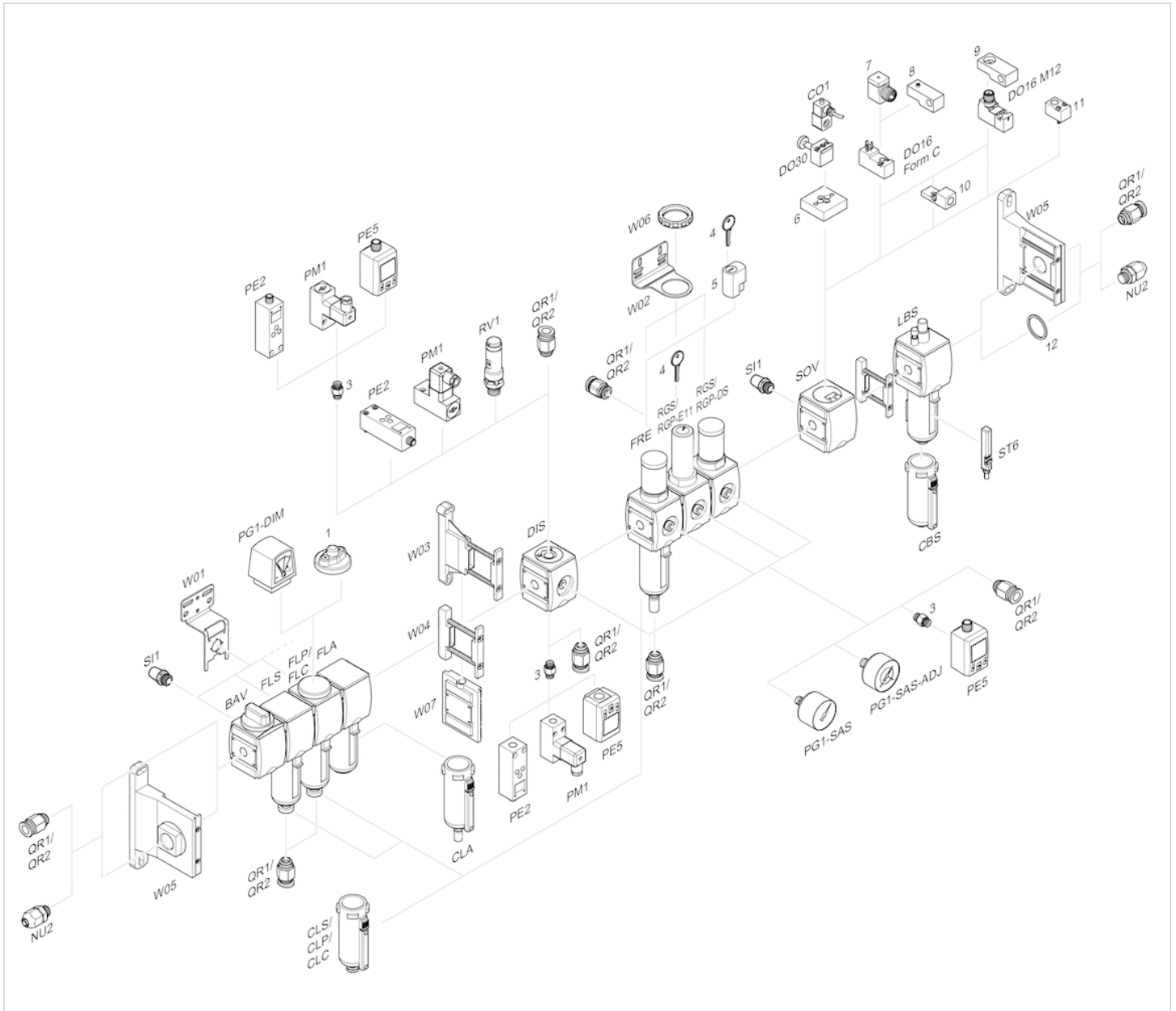

- 1 = contamination display
- 3 = Double nipple
- 4 = Key for E11 locking
- 5 = mortise lock
- 6 = Transition plate DO30
- 7 = Adapter, Series CON-VP
- 8 = Mounting aid DO16, form C
- 9 = Mounting aid DO16, M12
- 10 = Adapter for external pilot air
- 11 = Adapter pneumatic operation
- 12 = Sealing ring

Filter, Series AS2-FLS

- G 1/4 G 3/8
- filter porosity 5 μm
- suitable for ATEX

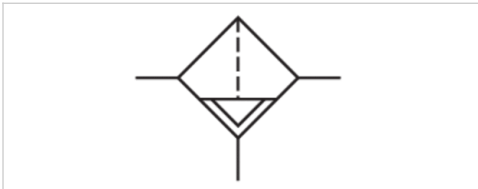

Version	Standard filter, Can be assembled into blocks
Parts	Filter
Mounting orientation	vertical
Certificates	suitable for ATEX
Working pressure min./max.	See table below
Ambient temperature min./max.	-10 ... 50 °C
Medium temperature min./max.	-10 ... 50 °C
Medium	Compressed air Neutral gases
Filter reservoir volume	28 cm ³
Filter element	exchangeable
filter porosity	5 μm
Condensate drain	See table below
Weight	See table below

Technical data

Part No.	Port	Flow Qn	Working pressure min./max.
R412006000	G 1/4	2100 l/min	1.5 ... 16 bar
R412006006	G 1/4	2100 l/min	1.5 ... 16 bar
R412006001	G 1/4	2100 l/min	1.5 ... 16 bar
R412006002	G 1/4	2100 l/min	1.5 ... 16 bar
R412006007	G 1/4	2100 l/min	1.5 ... 16 bar
R412006008	G 1/4	2100 l/min	1.5 ... 16 bar
R412006090	G 1/4	2100 l/min	0 ... 16 bar
R412006009	G 3/8	2100 l/min	1.5 ... 16 bar
R412006015	G 3/8	2100 l/min	1.5 ... 16 bar
R412006010	G 3/8	2100 l/min	1.5 ... 16 bar
R412006011	G 3/8	2100 l/min	1.5 ... 16 bar
R412006016	G 3/8	2100 l/min	1.5 ... 16 bar
R412006017	G 3/8	2100 l/min	1.5 ... 16 bar

Part No.	Condensate drain
R412006000	semi-automatic, open without pressure
R412006006	semi-automatic, open without pressure
R412006001	fully automatic, open without pressure
R412006002	fully automatic, closed without pressure
R412006007	fully automatic, open without pressure
R412006008	fully automatic, closed without pressure

Part No.	Condensate drain
R412006090	without
R412006009	semi-automatic, open without pressure
R412006015	semi-automatic, open without pressure
R412006010	fully automatic, open without pressure
R412006011	fully automatic, closed without pressure
R412006016	fully automatic, open without pressure
R412006017	fully automatic, closed without pressure

Part No.	Version	Weight	Fig.
R412006000	reservoir, polycarbonate, with PA protective guard	0.212 kg	Fig. 1
R412006006	-	0.443 kg	Fig. 1
R412006001	reservoir, polycarbonate, with PA protective guard	0.255 kg	Fig. 2
R412006002	reservoir, polycarbonate, with PA protective guard	0.255 kg	Fig. 2
R412006007	-	0.52 kg	Fig. 2
R412006008	-	0.53 kg	Fig. 2
R412006090	-	0.212 kg	Fig. 3
R412006009	reservoir, polycarbonate, with PA protective guard	0.212 kg	Fig. 4
R412006015	-	0.43 kg	Fig. 4
R412006010	reservoir, polycarbonate, with PA protective guard	0.255 kg	Fig. 5
R412006011	reservoir, polycarbonate, with PA protective guard	0.255 kg	Fig. 5
R412006016	-	0.52 kg	Fig. 5
R412006017	-	0.51 kg	Fig. 5

Nominal flow Q_n with secondary pressure $p_2 = 6$ bar at $\Delta p = 1$ bar

Suitable for use in Ex zones 1, 2, 21, 22.

Technical information

The pressure dew point must be at least 15 °C under ambient and medium temperature and may not exceed 3 °C .

Note: Polycarbonate reservoirs are susceptible to solvents, supplementary information can be found at "Customer information".

Suitable for use in Ex zones 1, 2, 21, 22.

A change in the flow direction (from air supply on the left to air supply on the right) occurs by rotating installation by 180° about the vertical axis. Please see the operating instructions for further details.

Also suitable for separation of fluid oil or water due to the design.

Max. achievable compressed air class acc. to ISO 8573-1:2010 6 : 7 : -

Technical information

Material	
Housing	Polyamide
Front plate	Acrylonitrile butadiene styrene
Seals	Acrylonitrile butadiene rubber
Threaded bushing	Die cast zinc
Reservoir	Polycarbonate Die cast zinc
Protective guard	Polyamide
Filter insert	Polyethylene

Dimensions

Dimensions in mm, Fig. 1

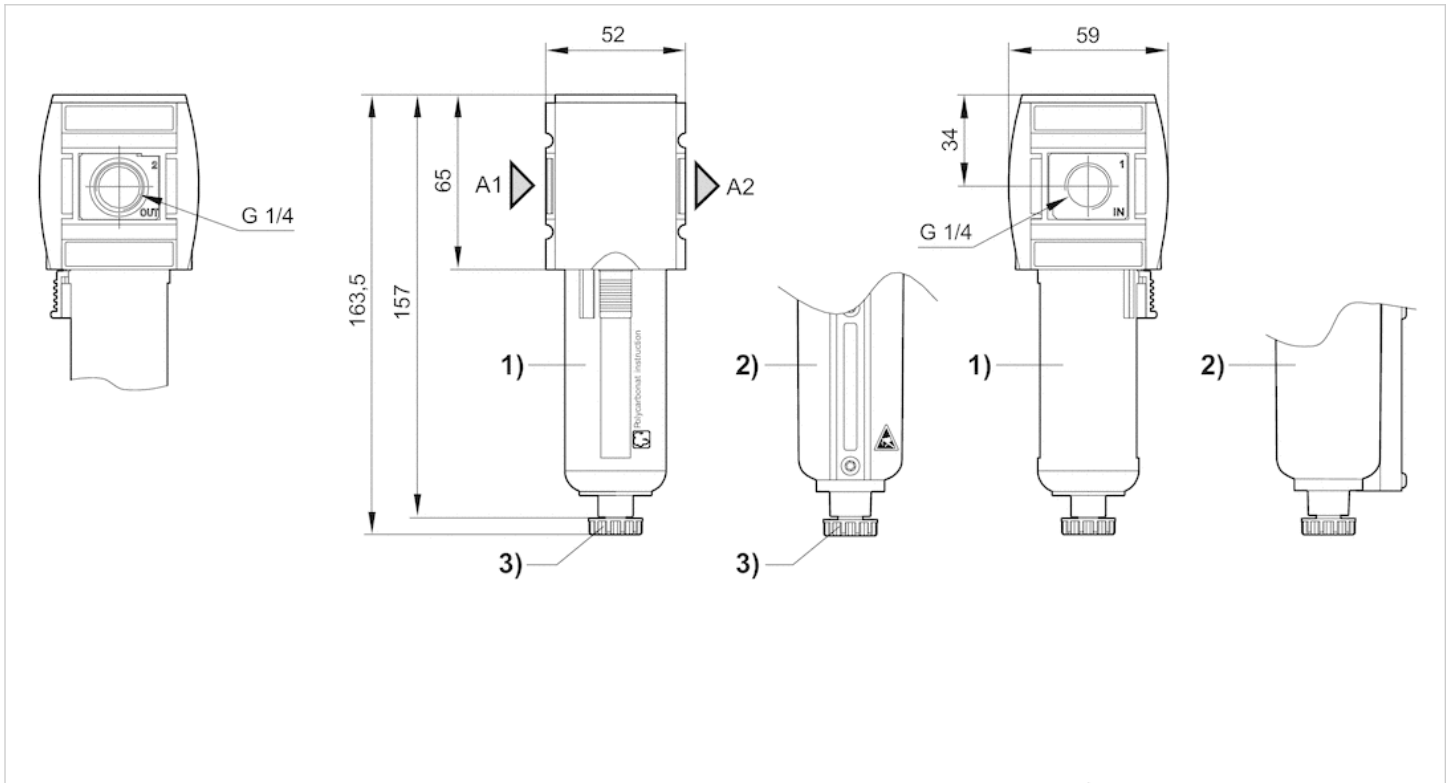

A1 = input

A2 = output

1) Plastic reservoir and protective guard with window

2) Metal reservoir with level indicator

3) Semi-automatic condensate drain

Dimensions in mm, Fig. 2

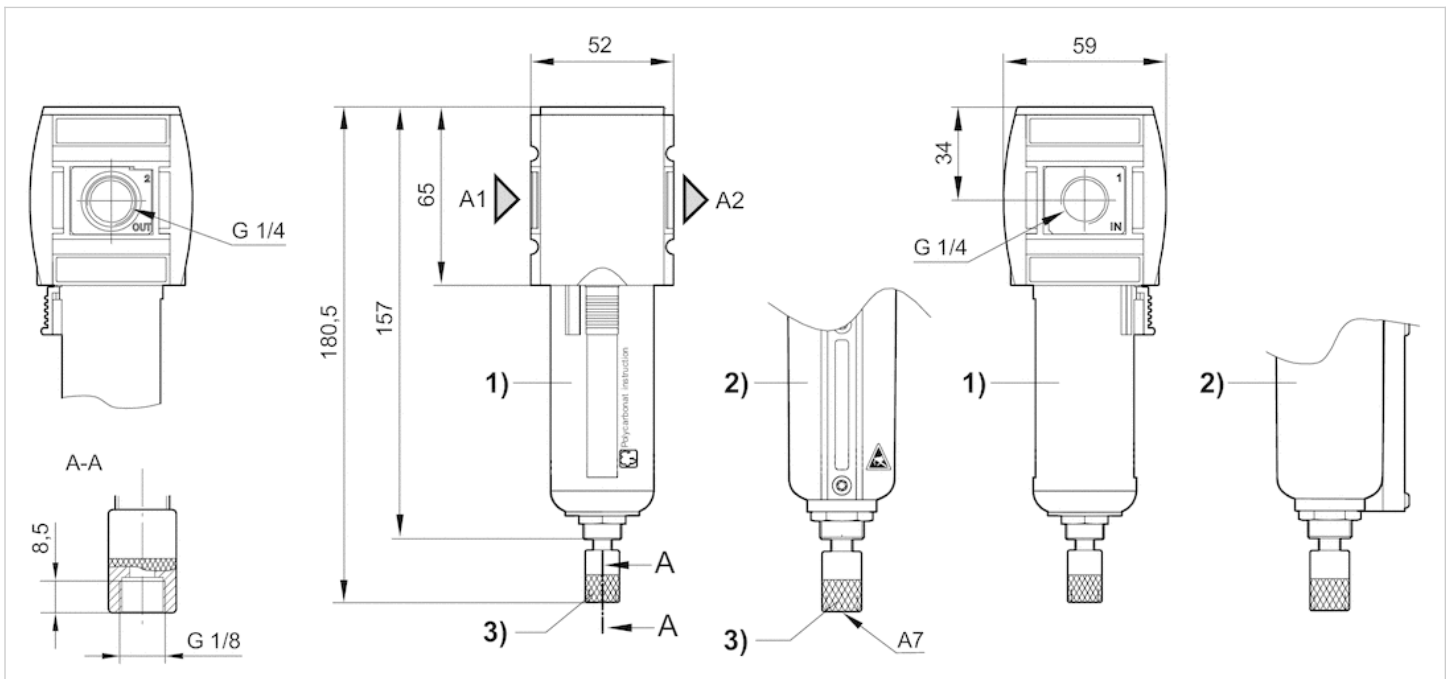

A1 = input

- A2 = output
- A7 = condensate drain
- 1) Plastic reservoir and protective guard with window
- 2) Metal reservoir with level indicator
- 3) Fully automatic condensate drain

Dimensions in mm, Fig. 3

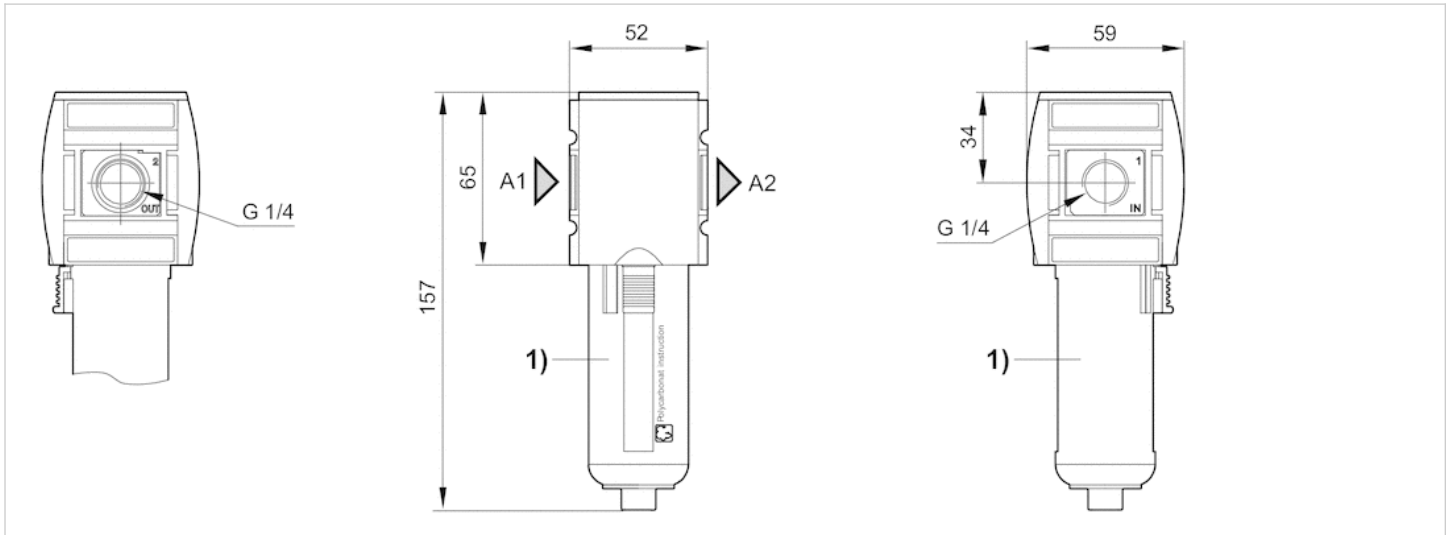

- A1 = input
- A2 = output
- 1) Plastic reservoir and protective guard with window

Dimensions in mm, Fig. 4

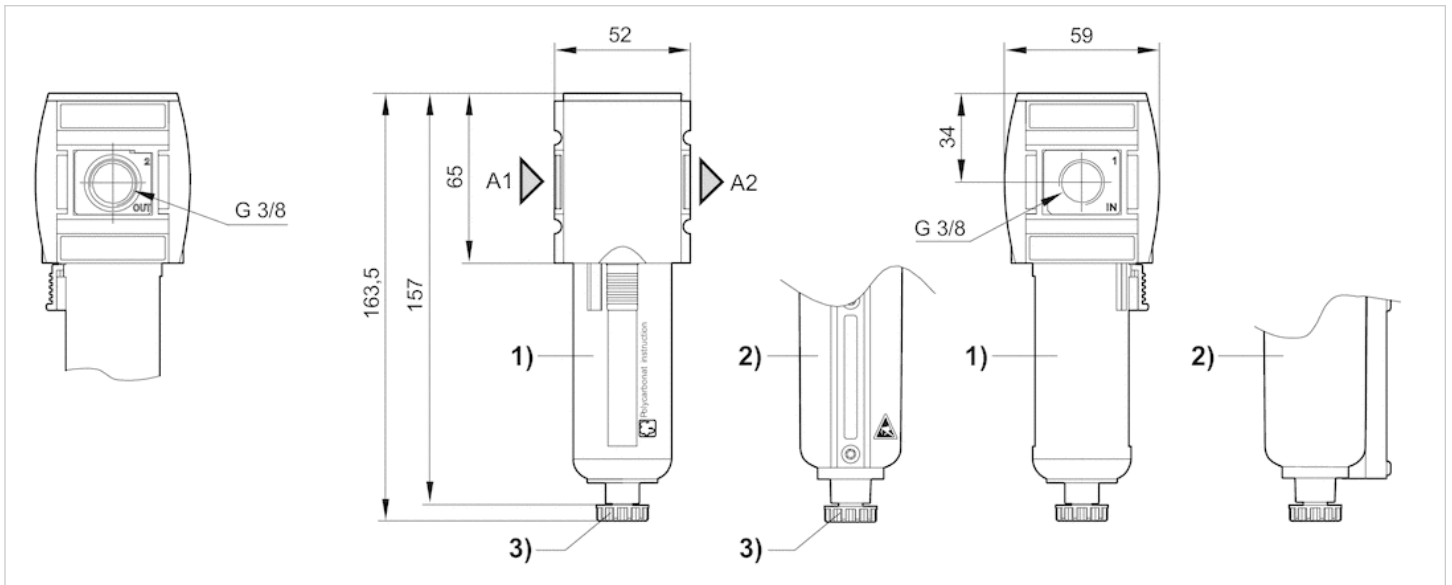

- A1 = input
- A2 = output
- 1) Plastic reservoir and protective guard with window
- 2) Metal reservoir with level indicator
- 3) Semi-automatic condensate drain

Dimensions in mm, Fig. 5

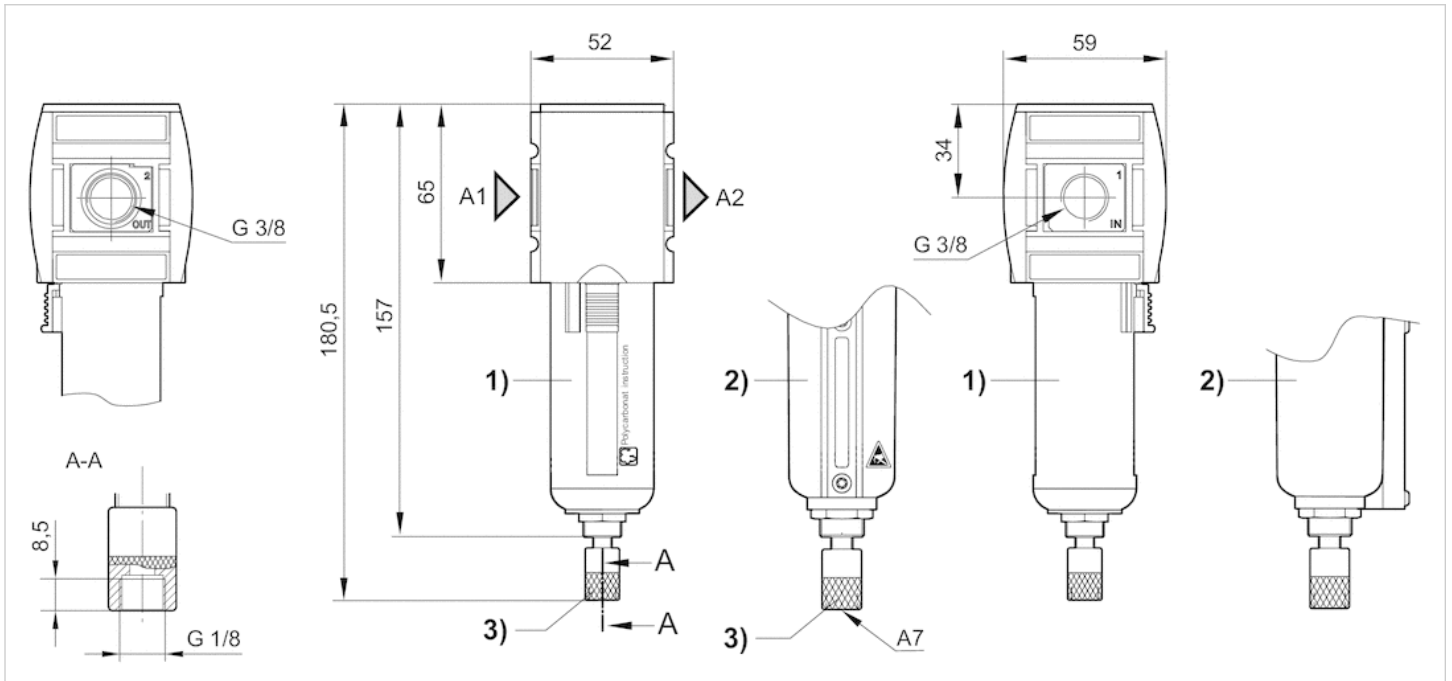

- A1 = input
- A2 = output
- A7 = condensate drain
- 1) Plastic reservoir and protective guard with window
- 2) Metal reservoir with level indicator
- 3) Fully automatic condensate drain

Diagrams

Flow rate characteristic

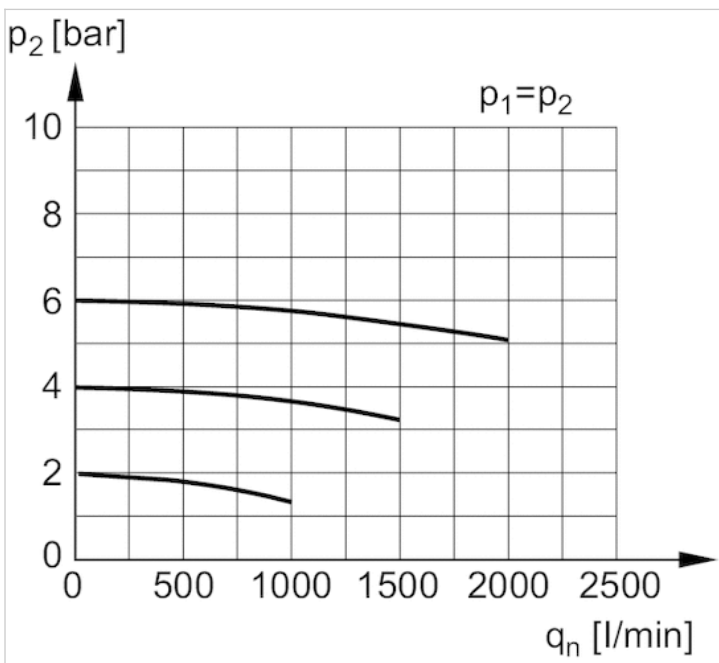

p_1 = Working pressure
 p_2 = Secondary pressure
 q_n = Nominal flow

Filter, Series AS2-FLS

- G 1/4
- filter porosity 25 μm
- suitable for ATEX

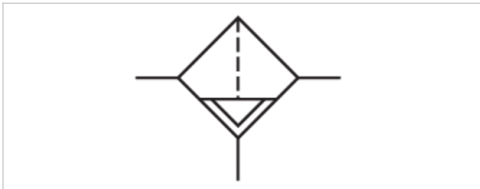

Version	Standard filter, Can be assembled into blocks
Parts	Filter
Mounting orientation	vertical
Certificates	suitable for ATEX
Working pressure min./max.	1.5 ... 16 bar
Ambient temperature min./max.	-10 ... 50 °C
Medium temperature min./max.	-10 ... 50 °C
Medium	Compressed air Neutral gases
Filter reservoir volume	28 cm ³
Filter element	exchangeable
filter porosity	25 μm
Condensate drain	semi-automatic, open without pressure
Weight	0.443 kg

Technical data

Part No.	Port	Flow Qn
R412006091	G 1/4	2100 l/min

Nominal flow Qn with secondary pressure p₂ = 6 bar at Δp = 1 bar

Suitable for use in Ex zones 1, 2, 21, 22.

Technical information

The pressure dew point must be at least 15 °C under ambient and medium temperature and may not exceed 3 °C .

Note: Polycarbonate reservoirs are susceptible to solvents, supplementary information can be found at "Customer information".

Suitable for use in Ex zones 1, 2, 21, 22.

A change in the flow direction (from air supply on the left to air supply on the right) occurs by rotating installation by 180° about the vertical axis. Please see the operating instructions for further details.

Also suitable for separation of fluid oil or water due to the design.

Max. achievable compressed air class acc. to ISO 8573-1:2010 7 : 7 : -

Technical information

Material	
Housing	Polyamide
Front plate	Acrylonitrile butadiene styrene
Seals	Acrylonitrile butadiene rubber

Material	
Threaded bushing	Die cast zinc
Reservoir	Die cast zinc
Filter insert	Polyethylene

Dimensions

Dimensions in mm

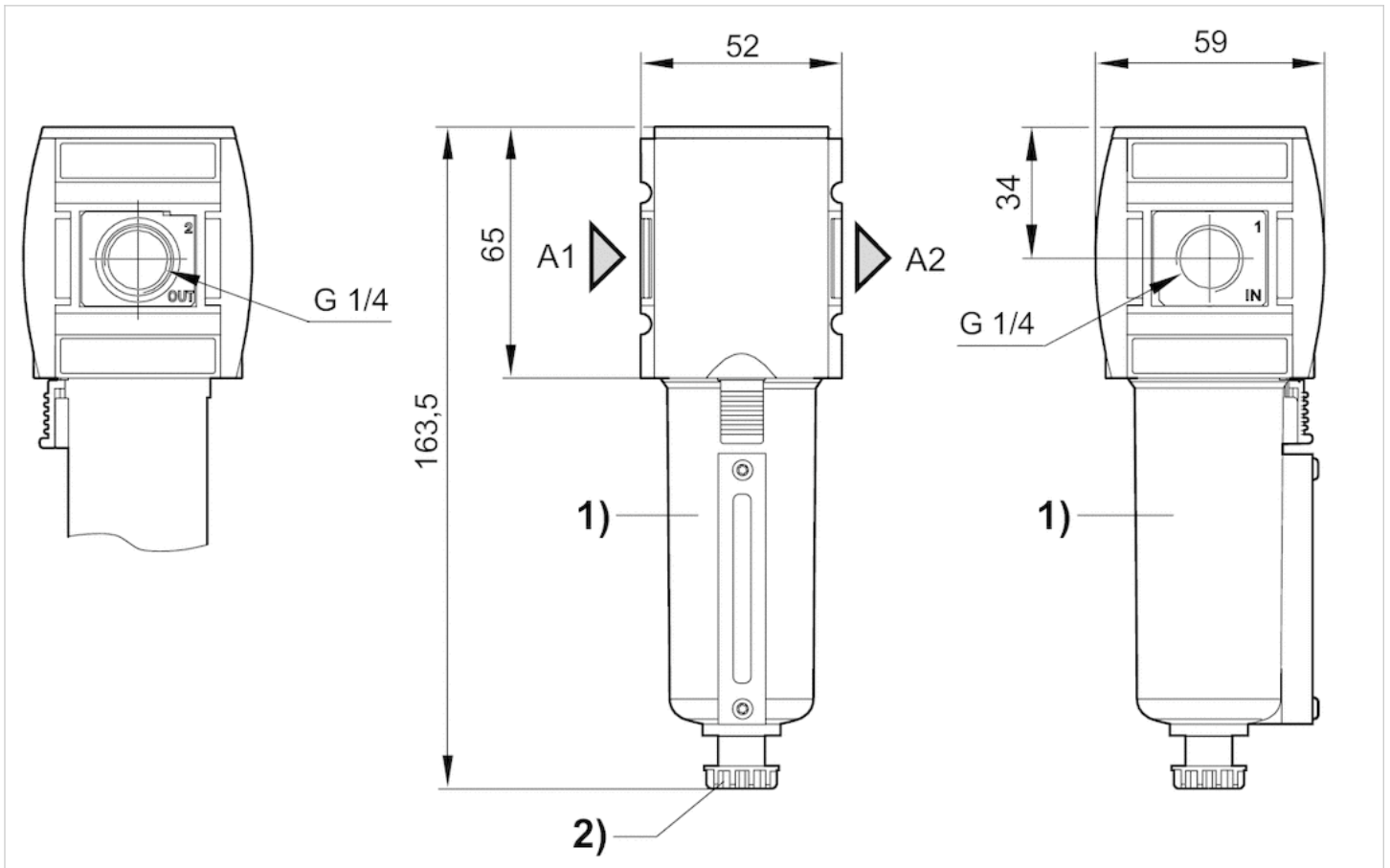

A1 = input

A2 = output

1) Metal reservoir with level indicator

2) Semi-automatic condensate drain

Diagrams

Flow rate characteristic

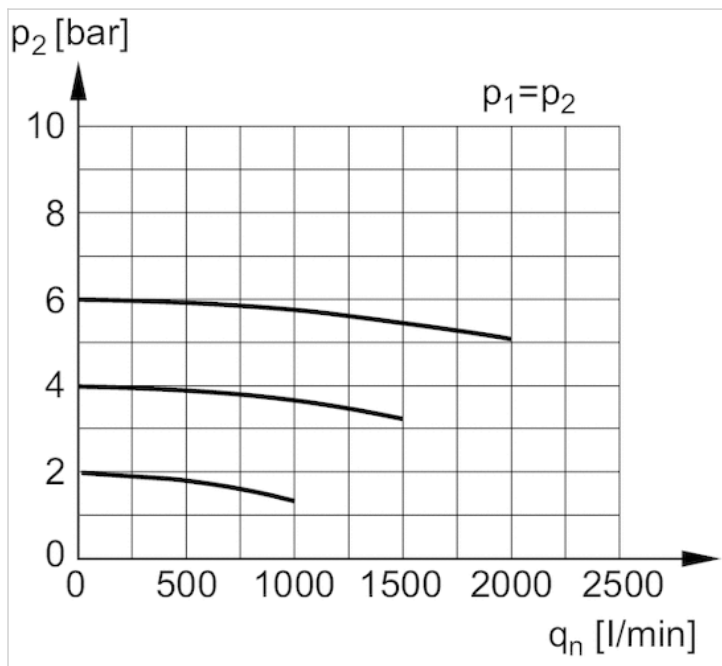

p_1 = Working pressure
 p_2 = Secondary pressure
 q_n = Nominal flow

Filter, Series AS2-FLS

- G 1/4 G 3/8
- filter porosity 40 µm
- suitable for ATEX

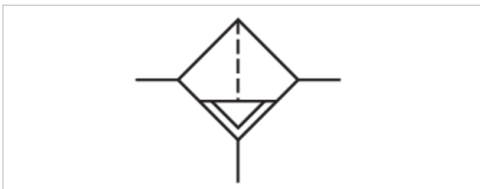

Version	Standard filter, Can be assembled into blocks
Parts	Filter
Mounting orientation	vertical
Certificates	suitable for ATEX
Working pressure min./max.	1.5 ... 16 bar
Ambient temperature min./max.	-10 ... 50 °C
Medium temperature min./max.	-10 ... 50 °C
Medium	Compressed air Neutral gases
Filter reservoir volume	28 cm ³
Filter element	exchangeable
filter porosity	40 µm
Condensate drain	See table below
Weight	See table below

Technical data

Part No.	Port	Flow Qn	Condensate drain	Weight	Fig.
R412006003	G 1/4	2100 l/min	semi-automatic, open without pressure	0.212 kg	Fig. 1
R412006004	G 1/4	2100 l/min	fully automatic, open without pressure	0.255 kg	Fig. 2
R412006005	G 1/4	2100 l/min	fully automatic, closed without pressure	0.255 kg	Fig. 2
R412006012	G 3/8	2100 l/min	semi-automatic, open without pressure	0.212 kg	Fig. 3
R412006013	G 3/8	2100 l/min	fully automatic, open without pressure	0.255 kg	Fig. 4
R412006014	G 3/8	2100 l/min	fully automatic, closed without pressure	0.255 kg	Fig. 4

Nominal flow Qn with secondary pressure p₂ = 6 bar at Δp = 1 bar

Suitable for use in Ex zones 1, 2, 21, 22.

Technical information

The pressure dew point must be at least 15 °C under ambient and medium temperature and may not exceed 3 °C .

Note: Polycarbonate reservoirs are susceptible to solvents, supplementary information can be found at "Customer information".

Suitable for use in Ex zones 1, 2, 21, 22.

A change in the flow direction (from air supply on the left to air supply on the right) occurs by rotating installation by 180° about the vertical axis. Please see the operating instructions for further details.

Also suitable for separation of fluid oil or water due to the design.

Max. achievable compressed air class acc. to ISO 8573-1:2010 7 : 7 : -

Technical information

Material	
Housing	Polyamide
Front plate	Acrylonitrile butadiene styrene
Seals	Acrylonitrile butadiene rubber
Threaded bushing	Die cast zinc
Reservoir	Polycarbonate
Protective guard	Polyamide
Filter insert	Polyethylene

Dimensions

Dimensions in mm, Fig. 1

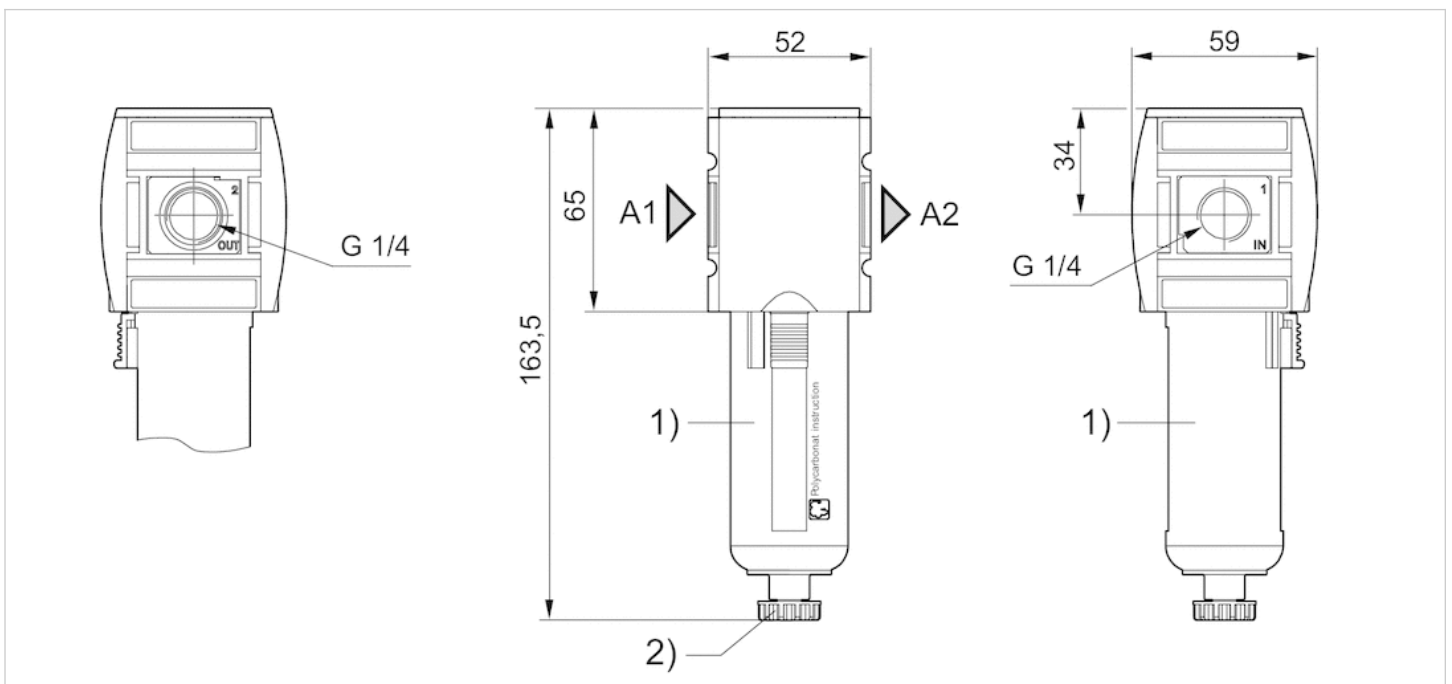

- A1 = input
- A2 = output
- 1) Plastic reservoir and protective guard with window
- 2) Semi-automatic condensate drain

Dimensions in mm, Fig. 2

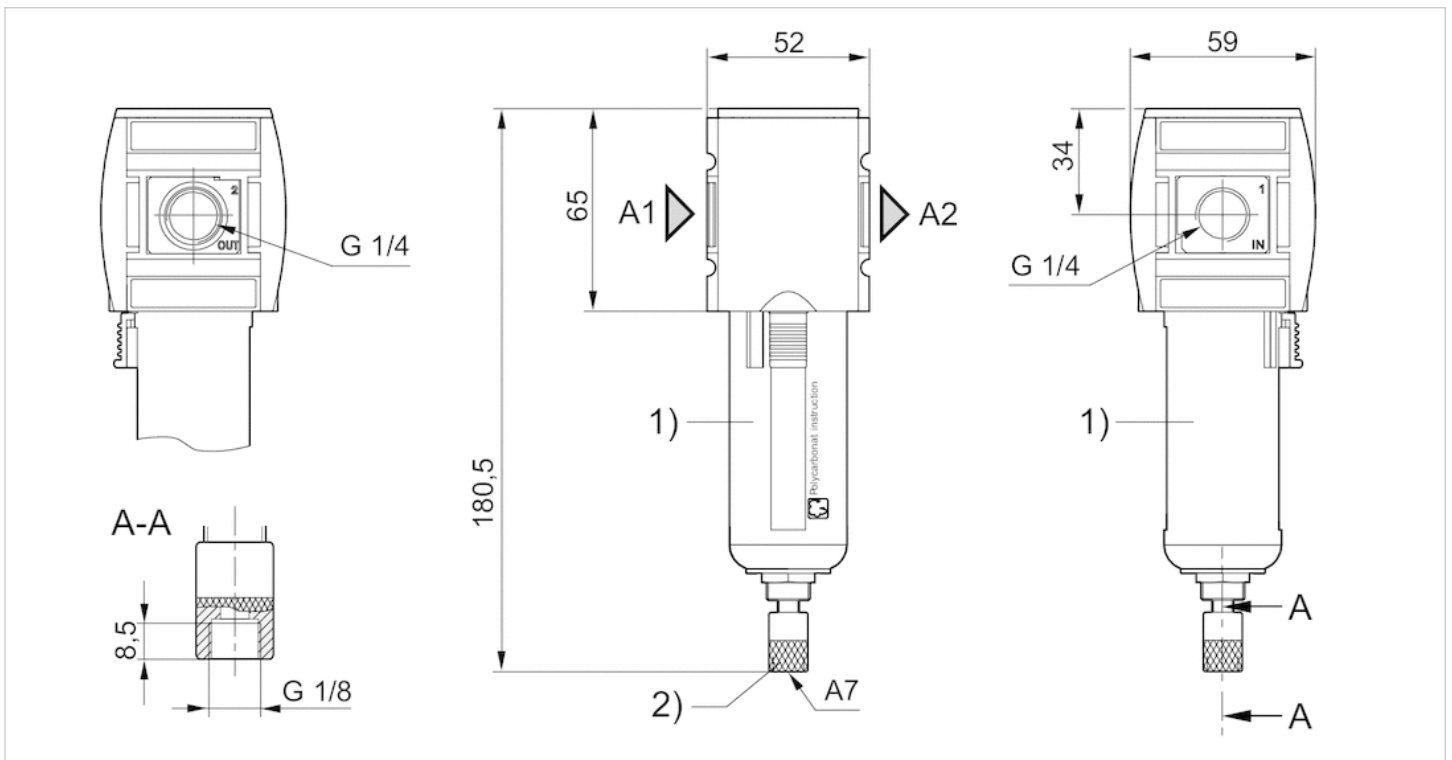

- A1 = input
- A2 = output
- A7 = condensate drain
- 1) Plastic reservoir and protective guard with window
- 2) Fully automatic condensate drain

Dimensions in mm, Fig. 3

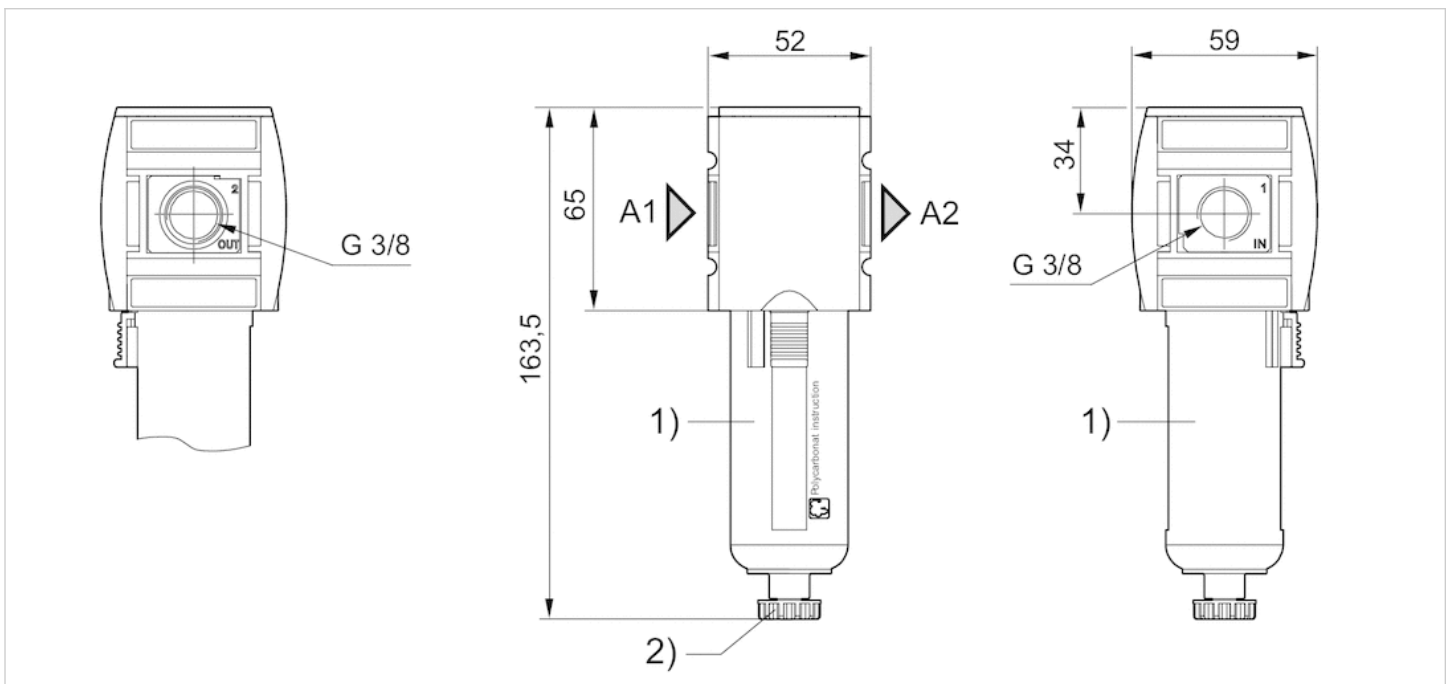

- A1 = input
- A2 = output
- 1) Plastic reservoir and protective guard with window
- 2) Semi-automatic condensate drain

Dimensions in mm, Fig. 4

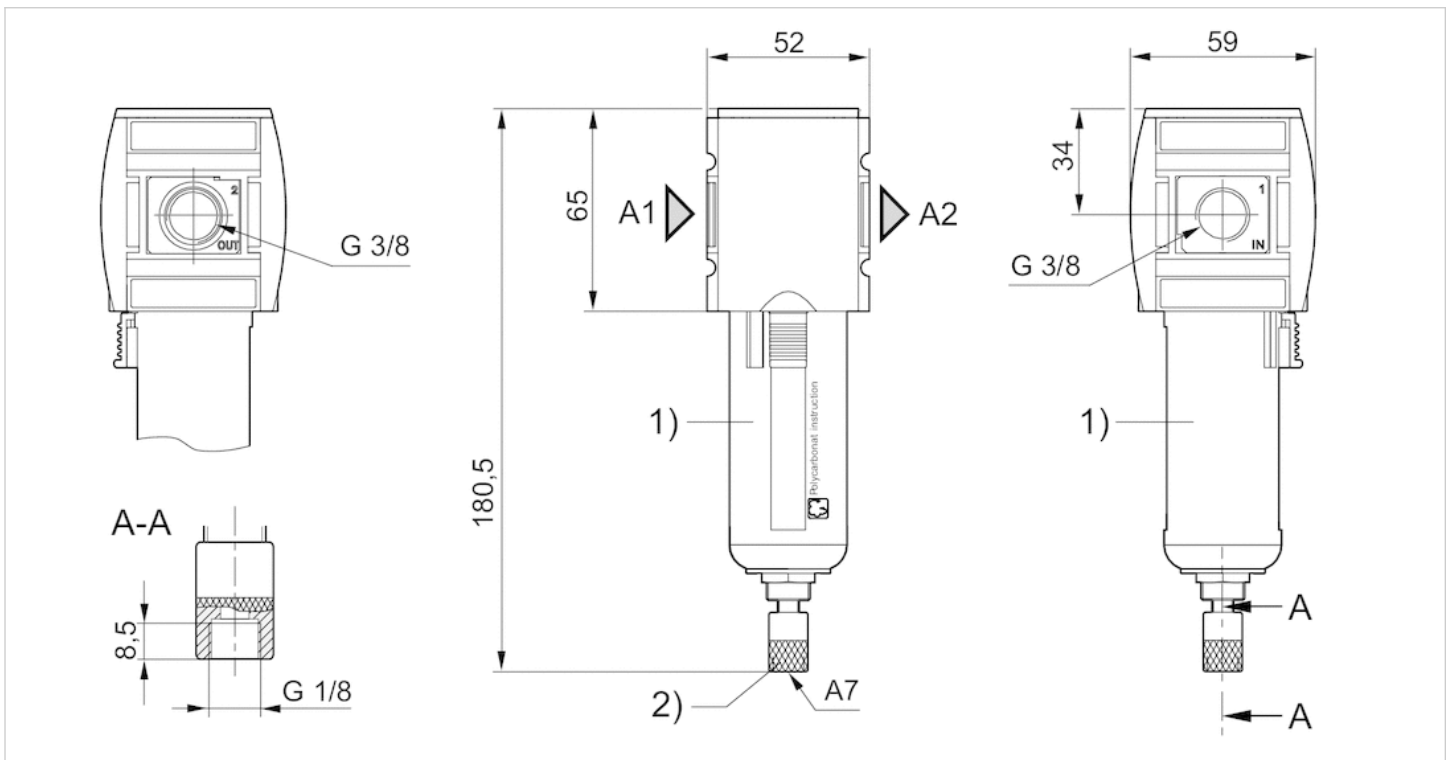

- A1 = input
- A2 = output
- A7 = condensate drain
- 1) Plastic reservoir and protective guard with window
- 2) Fully automatic condensate drain

Diagrams

Flow rate characteristic

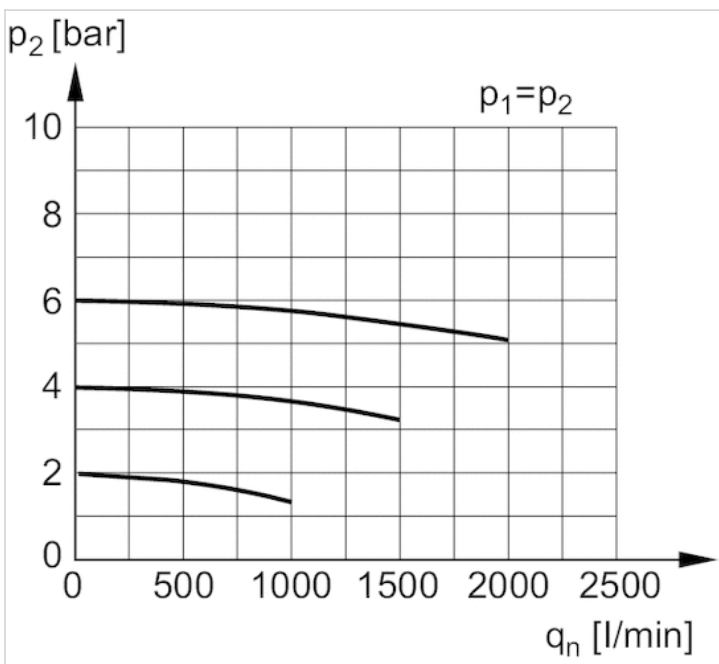

p_1 = Working pressure
 p_2 = Secondary pressure

qn = Nominal flow

Accessories overview

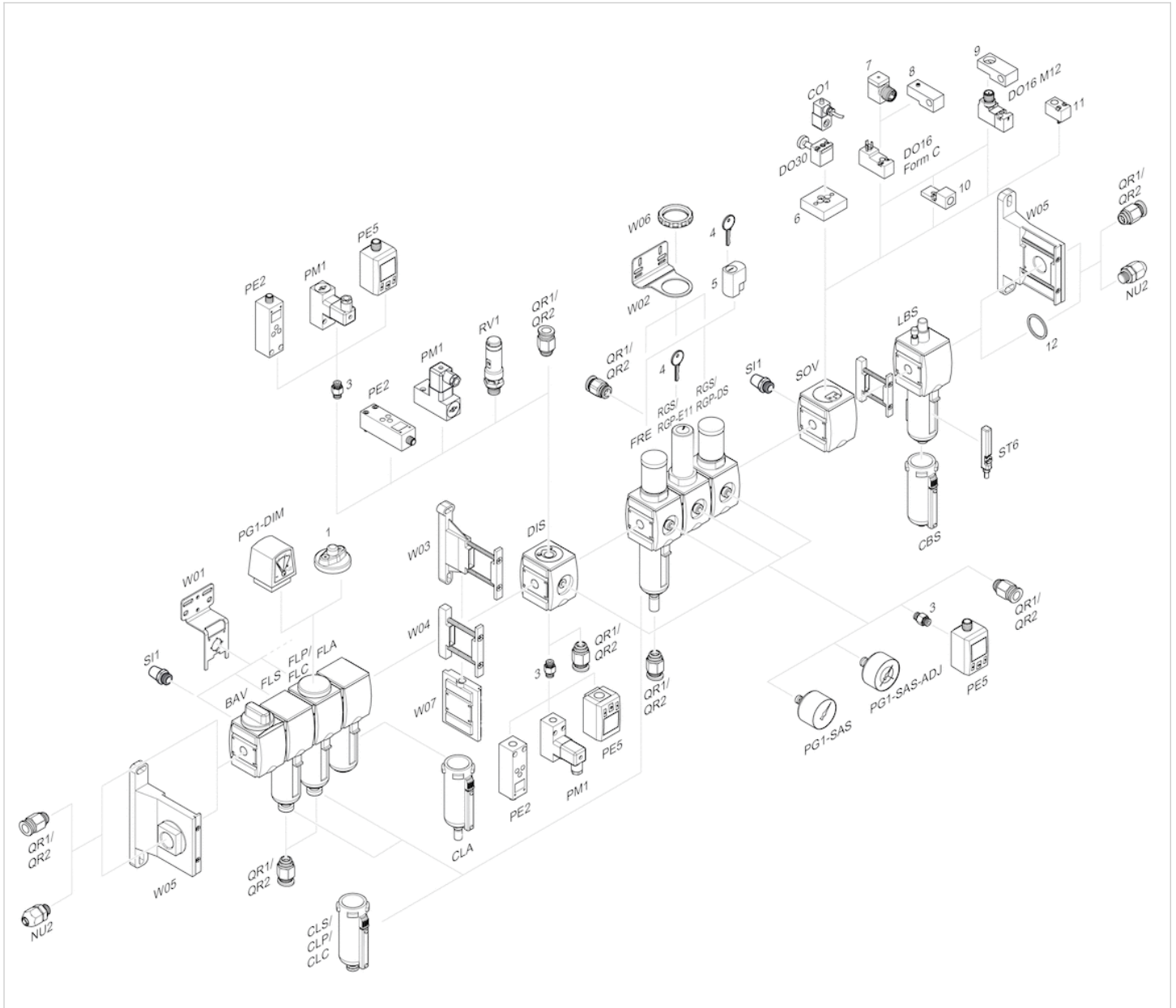

- 1 = contamination display
- 3 = Double nipple
- 4 = Key for E11 locking
- 5 = mortise lock
- 6 = Transition plate DO30
- 7 = Adapter, Series CON-VP
- 8 = Mounting aid DO16, form C
- 9 = Mounting aid DO16, M12
- 10 = Adapter for external pilot air
- 11 = Adapter pneumatic operation
- 12 = Sealing ring

Pre-filter, Series AS2-FLP

- G 1/4 G 3/8
- filter porosity 0.3 µm
- suitable for ATEX

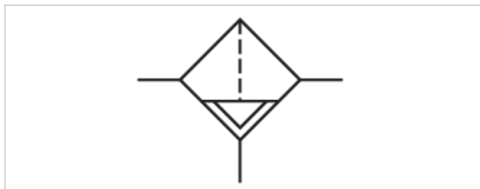

Version	Pre-filter, Can be assembled into blocks
Parts	Pre-filter
Mounting orientation	vertical
Certificates	suitable for ATEX
Working pressure min./max.	1.5 ... 16 bar
Ambient temperature min./max.	-10 ... 50 °C
Medium temperature min./max.	-10 ... 50 °C
Medium	Compressed air Neutral gases
Filter reservoir volume	12 cm ³
Filter element	exchangeable
filter porosity	0.3 µm
Condensate drain	See table below
Weight	See table below

Technical data

Part No.	Port	Flow Qn	Condensate drain
R412006018	G 1/4	400 l/min	semi-automatic, open without pressure
R412006019	G 1/4	400 l/min	fully automatic, open without pressure
R412006020	G 1/4	400 l/min	fully automatic, closed without pressure
R412006024	G 1/4	400 l/min	semi-automatic, open without pressure
R412006025	G 1/4	400 l/min	fully automatic, open without pressure
R412006026	G 1/4	400 l/min	fully automatic, closed without pressure
R412006027	G 3/8	400 l/min	semi-automatic, open without pressure
R412006028	G 3/8	400 l/min	fully automatic, open without pressure
R412006029	G 3/8	400 l/min	fully automatic, closed without pressure
R412006033	G 3/8	400 l/min	semi-automatic, open without pressure
R412006034	G 3/8	400 l/min	fully automatic, open without pressure
R412006035	G 3/8	400 l/min	fully automatic, closed without pressure

Part No.	Version	Weight	Fig.
R412006018	reservoir, polycarbonate, with PA protective guard	0.22 kg	Fig. 1
R412006019	reservoir, polycarbonate, with PA protective guard	0.263 kg	Fig. 2
R412006020	reservoir, polycarbonate, with PA protective guard	0.263 kg	Fig. 2
R412006024	reservoir, metal, with inspection glass	0.484 kg	Fig. 1
R412006025	reservoir, metal, with inspection glass	0.53 kg	Fig. 2
R412006026	reservoir, metal, with inspection glass	0.53 kg	Fig. 2
R412006027	reservoir, polycarbonate, with PA protective guard	0.263 kg	Fig. 3

Part No.	Version	Weight	Fig.
R412006028	reservoir, polycarbonate, with PA protective guard	0.263 kg	Fig. 4
R412006029	reservoir, polycarbonate, with PA protective guard	0.263 kg	Fig. 4
R412006033	reservoir, metal, with inspection glass	0.47 kg	Fig. 3
R412006034	reservoir, metal, with inspection glass	0.525 kg	Fig. 4
R412006035	reservoir, metal, with inspection glass	0.525 kg	Fig. 4

Nominal flow Q_n with secondary pressure $p_2 = 6$ bar at $\Delta p = 0.1$ bar

Suitable for use in Ex zones 1, 2, 21, 22.

Technical information

The pressure dew point must be at least 15 °C under ambient and medium temperature and may not exceed 3 °C .

Note: Polycarbonate reservoirs are susceptible to solvents, supplementary information can be found at "Customer information".

Suitable for use in Ex zones 1, 2, 21, 22.

A change in the flow direction (from air supply on the left to air supply on the right) occurs by rotating installation by 180° about the vertical axis. Please see the operating instructions for further details.

Recommended pre-filtering 5 µm

Max. achievable compressed air class acc. to ISO 8573-1:2010 2 : - : 3

Technical information

Material	
Housing	Polyamide
Front plate	Acrylonitrile butadiene styrene
Seals	Acrylonitrile butadiene rubber
Threaded bushing	Die cast zinc
Reservoir	Polycarbonate Die cast zinc
Protective guard	Polyamide
Filter insert	Impregnated paper

Dimensions

Dimensions in mm, Fig. 1

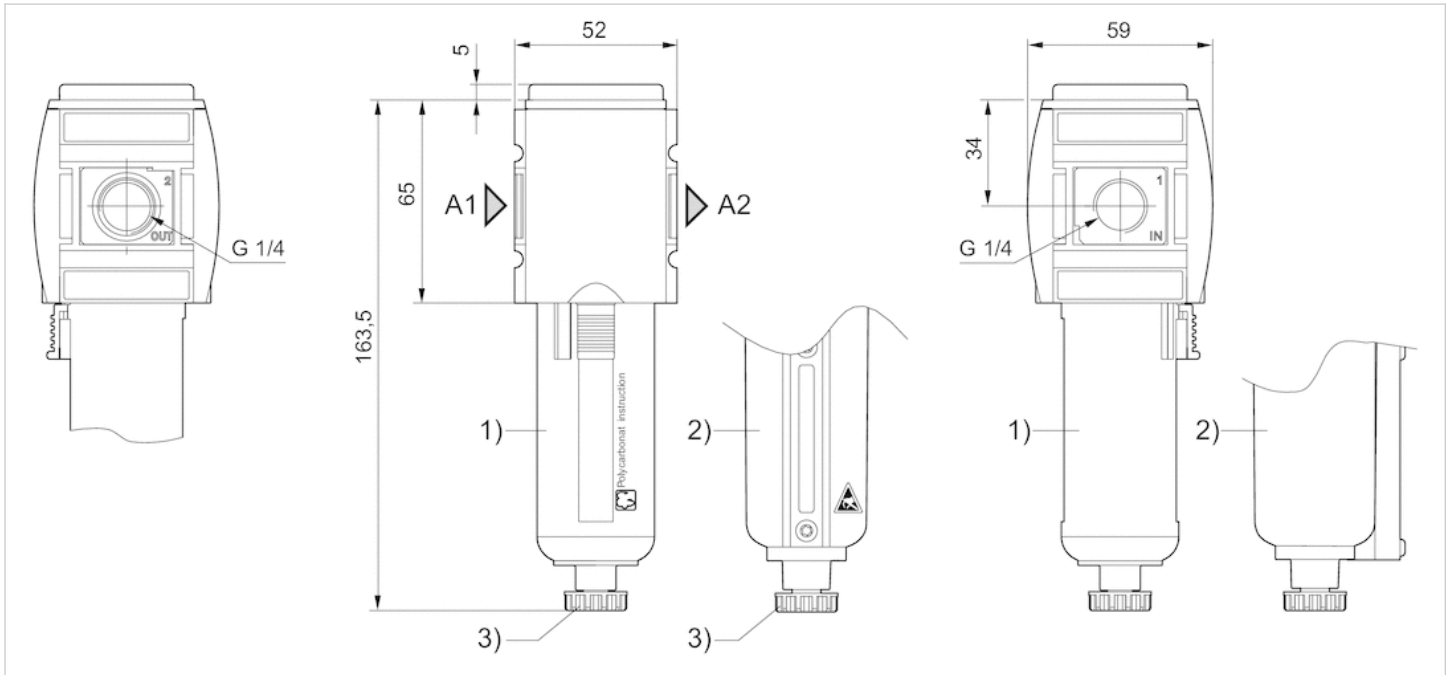

A1 = input

A2 = output

1) Plastic reservoir and protective guard with window

2) Metal reservoir with level indicator

3) Semi-automatic condensate drain

Dimensions in mm, Fig. 2

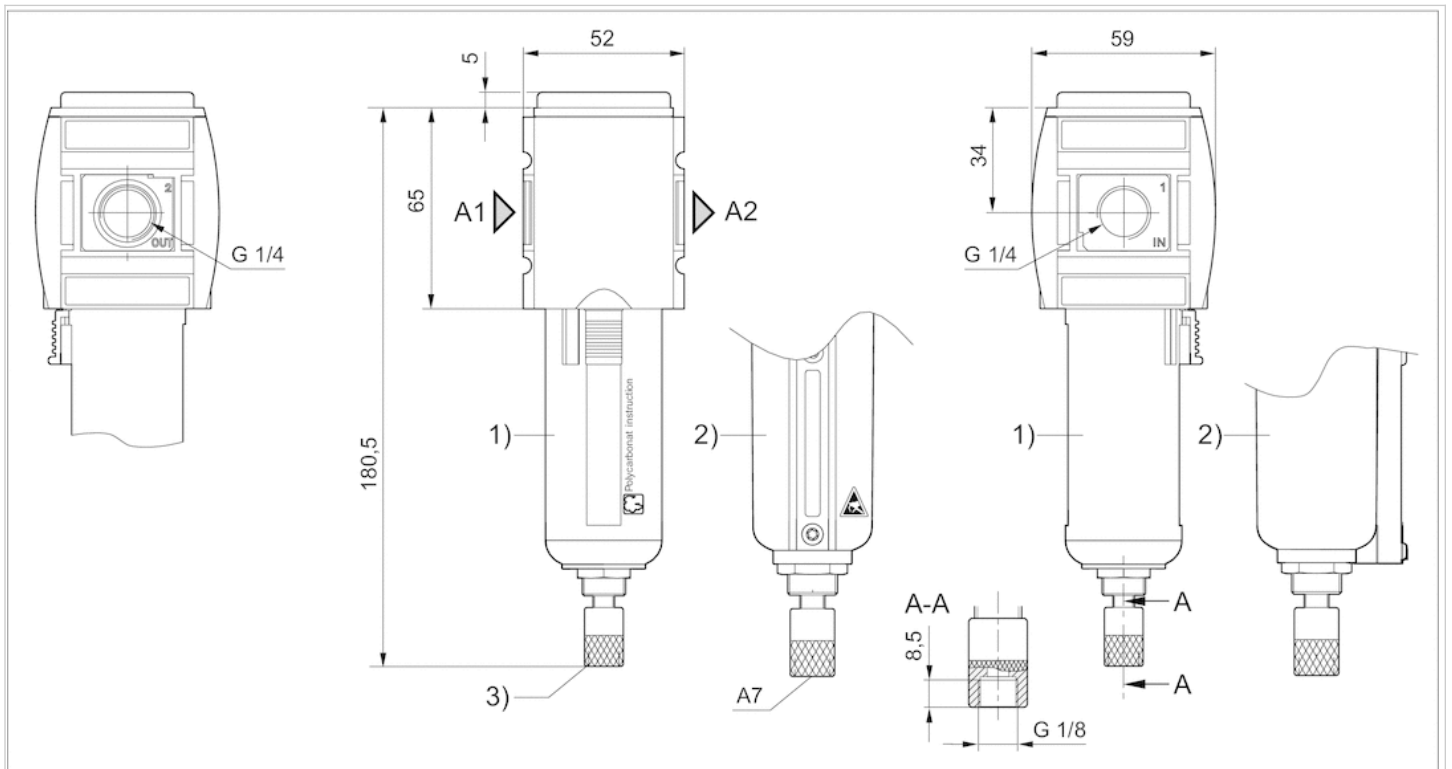

A1 = input

A2 = output

- A7 = condensate drain
- 1) Plastic reservoir and protective guard with window
 - 2) Metal reservoir with level indicator
 - 3) Fully automatic condensate drain

Dimensions in mm, Fig. 3

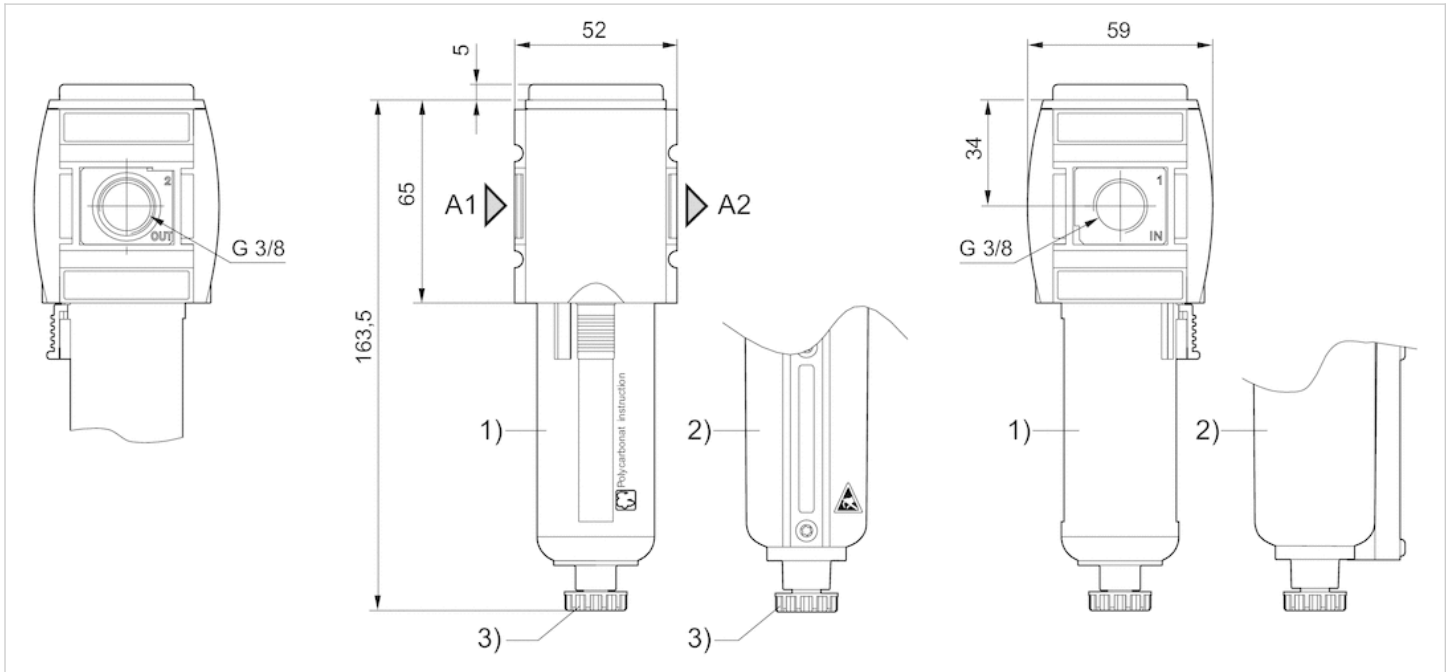

- A1 = input
 A2 = output
- 1) Plastic reservoir and protective guard with window
 - 2) Metal reservoir with level indicator
 - 3) Semi-automatic condensate drain

Dimensions in mm, Fig. 4

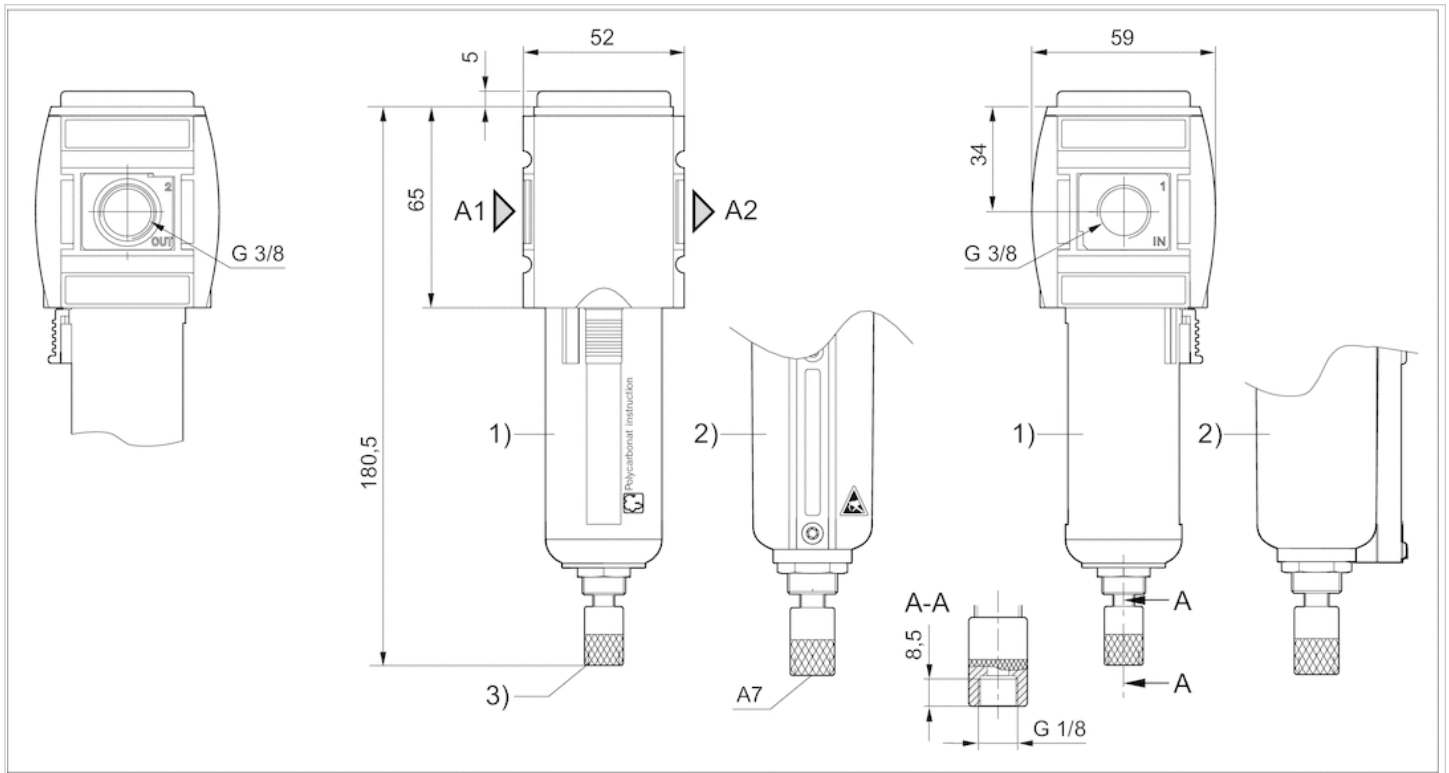

- A1 = input
- A2 = output
- A7 = condensate drain
- 1) Plastic reservoir and protective guard with window
- 2) Metal reservoir with level indicator
- 3) Fully automatic condensate drain

Diagrams

Flow rate characteristic

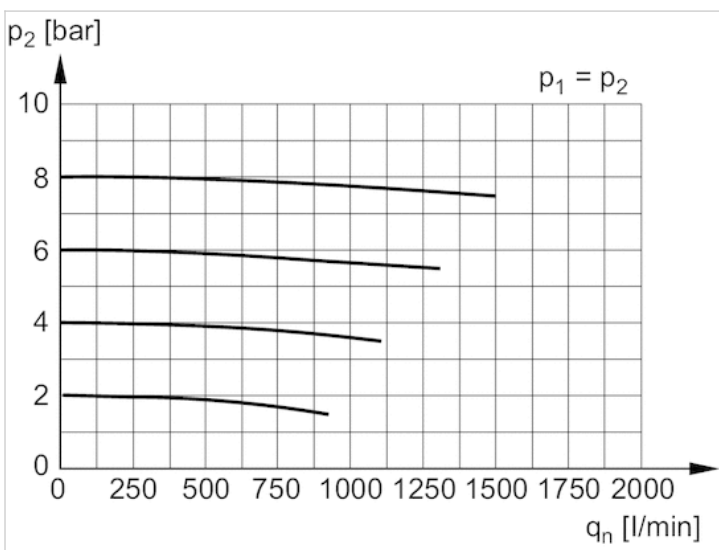

- p_1 = Working pressure
- p_2 = Secondary pressure
- q_n = Nominal flow

Accessories overview

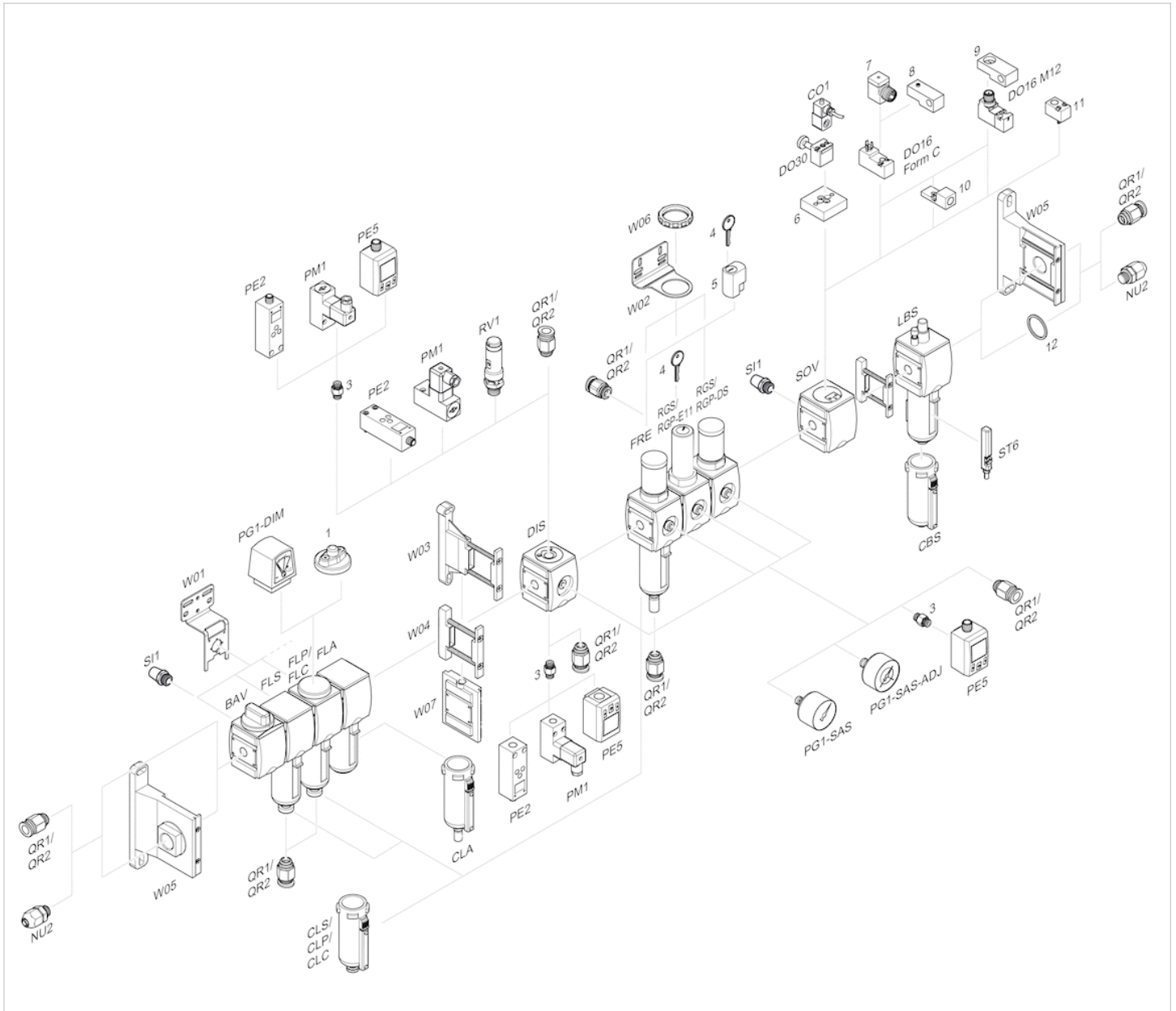

- 1 = contamination display
- 3 = Double nipple
- 4 = Key for E11 locking
- 5 = mortise lock
- 6 = Transition plate DO30
- 7 = Adapter, Series CON-VP
- 8 = Mounting aid DO16, form C
- 9 = Mounting aid DO16, M12
- 10 = Adapter for external pilot air
- 11 = Adapter pneumatic operation
- 12 = Sealing ring

Microfilter, Series AS2-FLC

- G 1/4 G 3/8
- filter porosity 0.01 µm
- suitable for ATEX

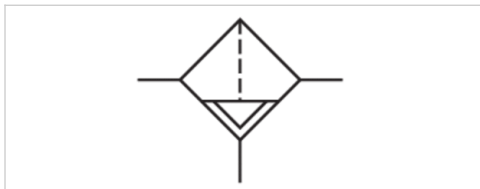

Version	Microfilter, Can be assembled into blocks
Parts	Microfilter
Mounting orientation	vertical
Certificates	suitable for ATEX
Working pressure min./max.	1.5 ... 16 bar
Ambient temperature min./max.	-10 ... 50 °C
Medium temperature min./max.	-10 ... 50 °C
Medium	Compressed air Neutral gases
Filter reservoir volume	12 cm ³
Filter element	exchangeable
filter porosity	0.01 µm
Condensate drain	See table below
Weight	See table below

Technical data

Part No.	Port	Flow Qn	Condensate drain
R412006036	G 1/4	350 l/min	semi-automatic, open without pressure
R412006037	G 1/4	350 l/min	fully automatic, open without pressure
R412006038	G 1/4	350 l/min	fully automatic, closed without pressure
R412006042	G 1/4	350 l/min	semi-automatic, open without pressure
R412006043	G 1/4	350 l/min	fully automatic, open without pressure
R412006044	G 1/4	350 l/min	fully automatic, closed without pressure
R412006045	G 3/8	350 l/min	semi-automatic, open without pressure
R412006046	G 3/8	350 l/min	fully automatic, open without pressure
R412006047	G 3/8	350 l/min	fully automatic, closed without pressure
R412006051	G 3/8	350 l/min	semi-automatic, open without pressure
R412006052	G 3/8	350 l/min	fully automatic, open without pressure
R412006053	G 3/8	350 l/min	fully automatic, closed without pressure

Part No.	Version	Weight	Fig.
R412006036	reservoir, polycarbonate, with PA protective guard	0.22 kg	Fig. 1
R412006037	reservoir, polycarbonate, with PA protective guard	0.263 kg	Fig. 2
R412006038	reservoir, polycarbonate, with PA protective guard	0.263 kg	Fig. 2
R412006042	reservoir, metal, with inspection glass	0.482 kg	Fig. 1
R412006043	reservoir, metal, with inspection glass	0.565 kg	Fig. 2
R412006044	reservoir, metal, with inspection glass	0.56 kg	Fig. 2
R412006045	reservoir, polycarbonate, with PA protective guard	0.22 kg	Fig. 3

Part No.	Version	Weight	Fig.
R412006046	reservoir, polycarbonate, with PA protective guard	0.263 kg	Fig. 4
R412006047	reservoir, polycarbonate, with PA protective guard	0.263 kg	Fig. 4
R412006051	reservoir, metal, with inspection glass	0.471 kg	Fig. 3
R412006052	reservoir, metal, with inspection glass	0.545 kg	Fig. 4
R412006053	reservoir, metal, with inspection glass	0.55 kg	Fig. 4

Nominal flow Q_n with secondary pressure $p_2 = 6$ bar at $\Delta p = 0.1$ bar

Suitable for use in Ex zones 1, 2, 21, 22.

Technical information

The pressure dew point must be at least 15 °C under ambient and medium temperature and may not exceed 3 °C .

Note: Polycarbonate reservoirs are susceptible to solvents, supplementary information can be found at "Customer information".

Suitable for use in Ex zones 1, 2, 21, 22.

A change in the flow direction (from air supply on the left to air supply on the right) occurs by rotating installation by 180° about the vertical axis. Please see the operating instructions for further details.

Recommended pre-filtering 0.3 µm

Max. achievable compressed air class acc. to ISO 8573-1:2010 1 : - : 2

Technical information

Material	
Housing	Polyamide
Front plate	Acrylonitrile butadiene styrene
Seals	Acrylonitrile butadiene rubber
Threaded bushing	Die cast zinc
Reservoir	Polycarbonate Die cast zinc
Protective guard	Polyamide
Filter insert	Borosilicate glass fiber

Dimensions

Dimensions in mm, Fig. 1

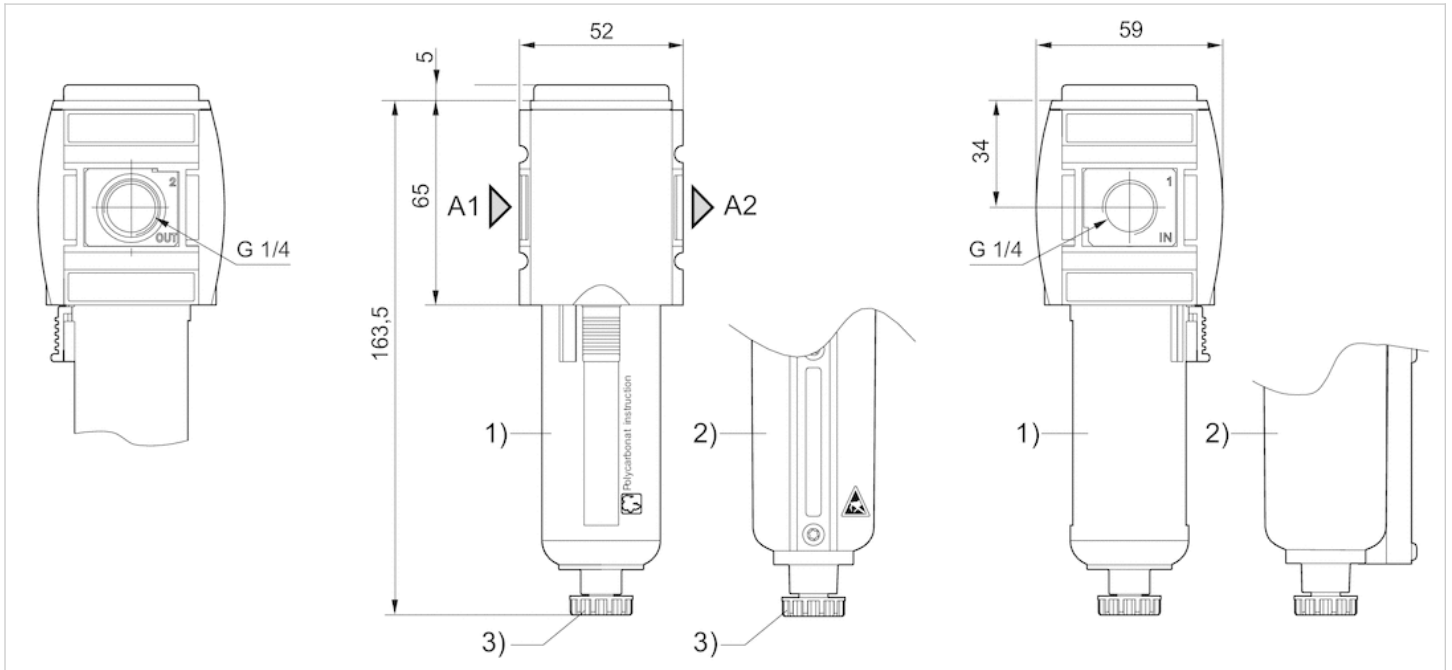

A1 = input

A2 = output

1) Plastic reservoir and protective guard with window

2) Metal reservoir with level indicator

3) Semi-automatic condensate drain

Dimensions in mm, Fig. 2

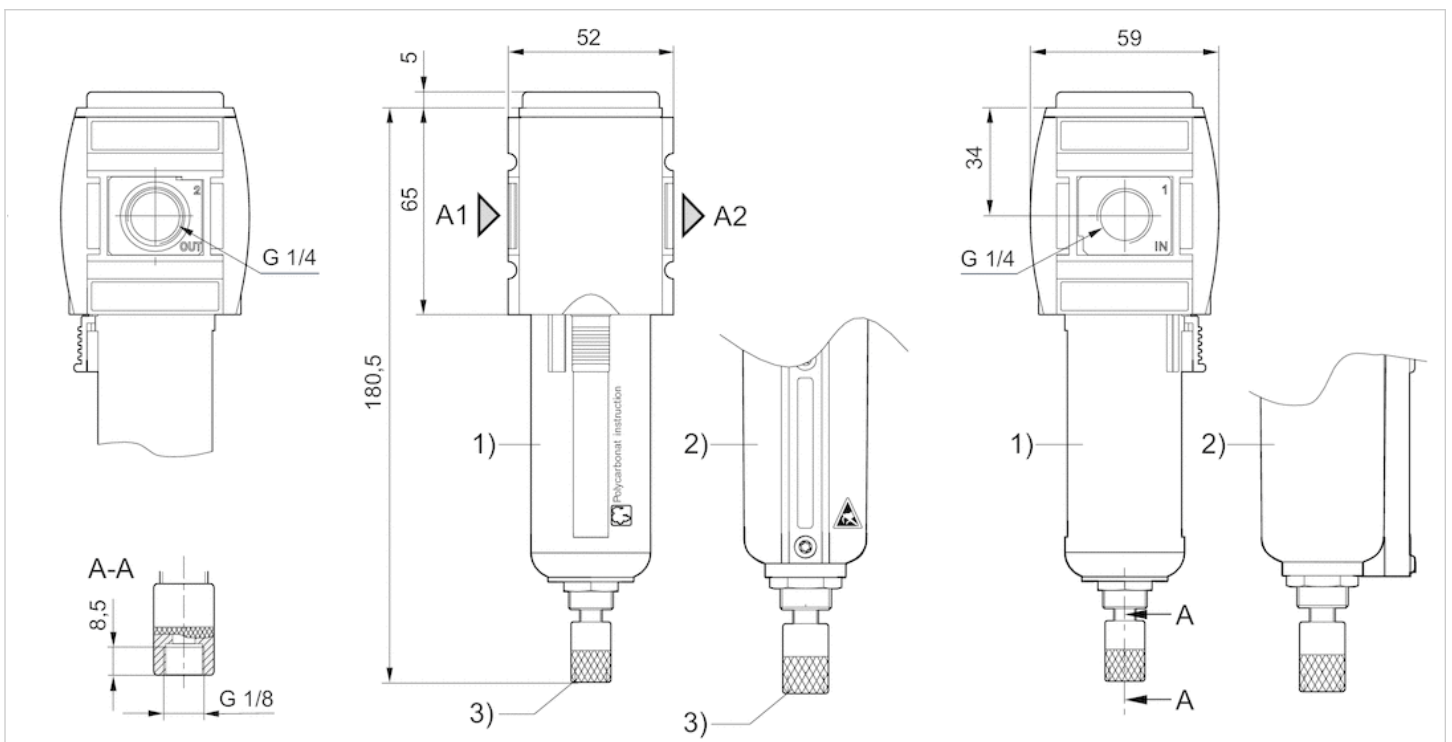

A1 = input

A2 = output

A7 = condensate drain

- 1) Plastic reservoir and protective guard with window
- 2) Metal reservoir with inspection glass
- 3) Fully automatic condensate drain

Dimensions in mm, Fig. 3

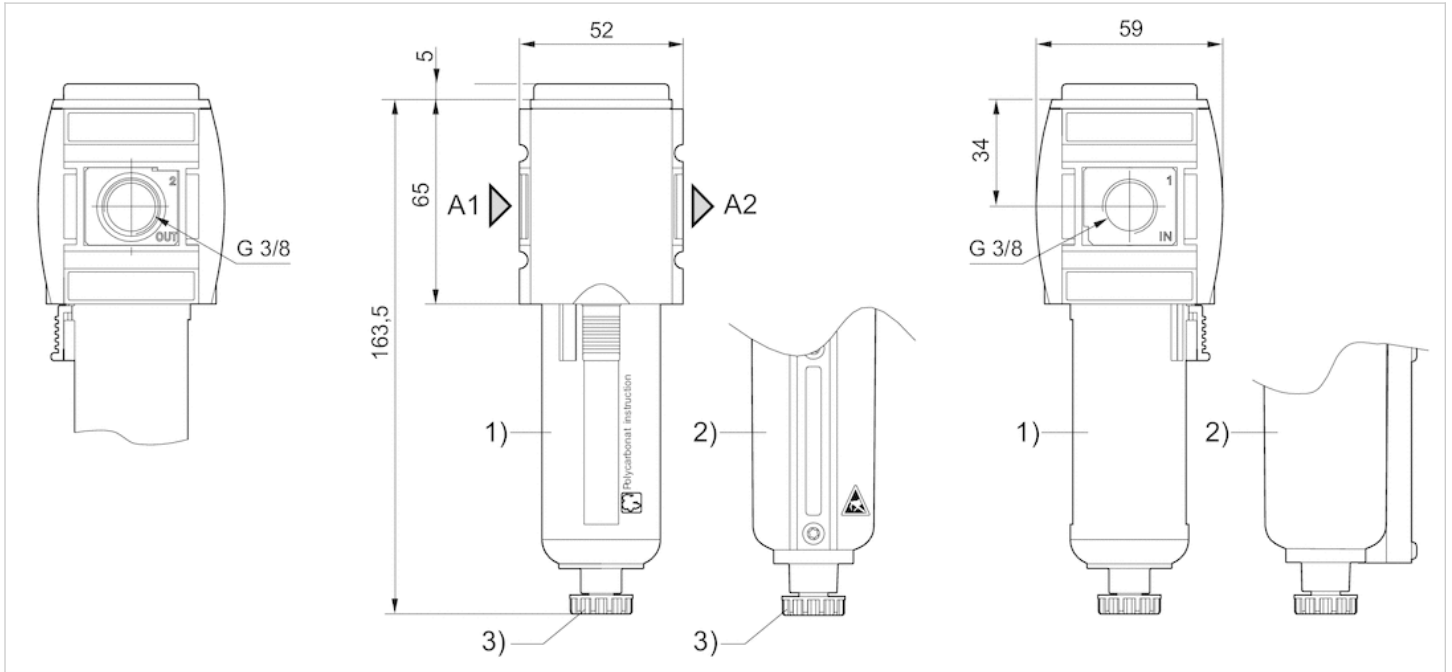

A1 = input

A2 = output

- 1) Plastic reservoir and protective guard with window
- 2) Metal reservoir with level indicator
- 3) Semi-automatic condensate drain

Dimensions in mm, Fig. 4

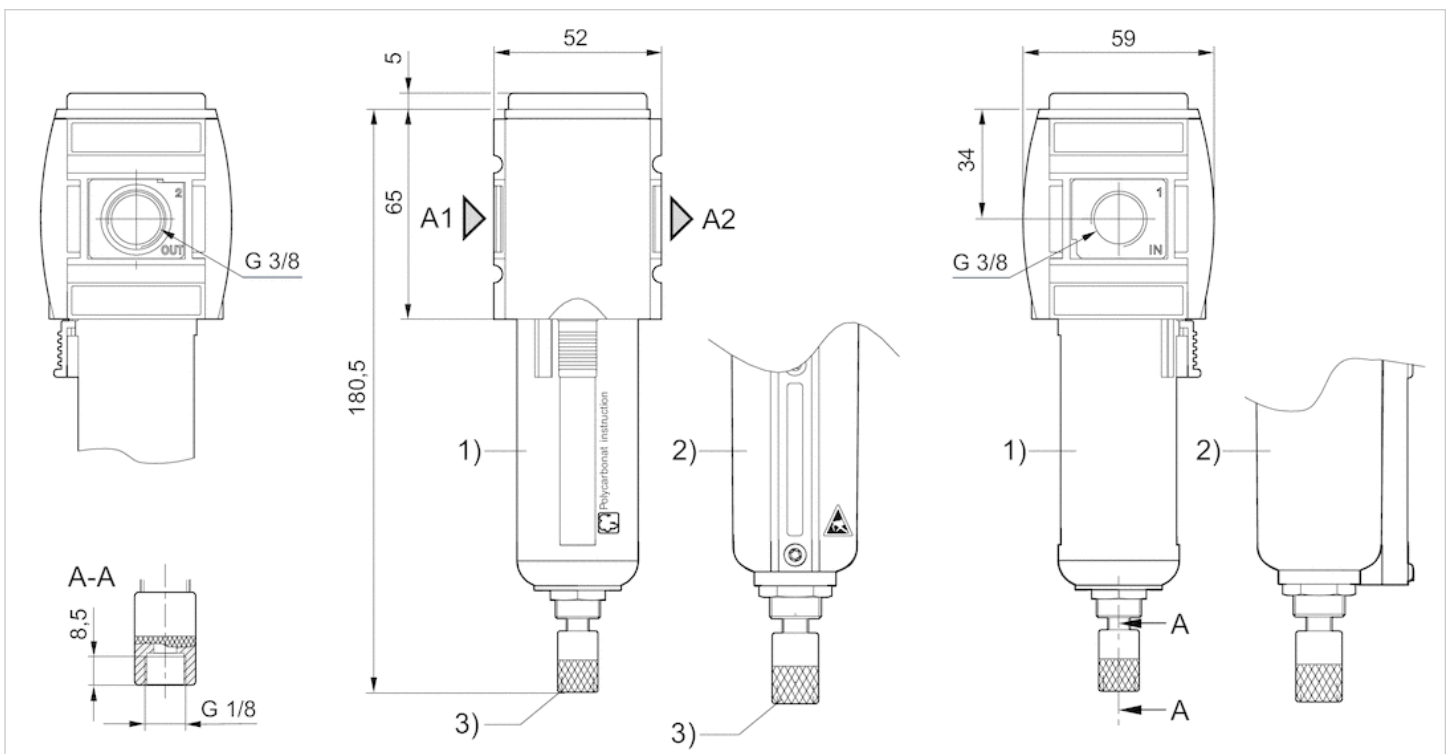

A1 = input

A2 = output

A7 = condensate drain

1) Plastic reservoir and protective guard with window

2) Metal reservoir with inspection glass

3) Fully automatic condensate drain

Diagrams

Flow rate characteristic

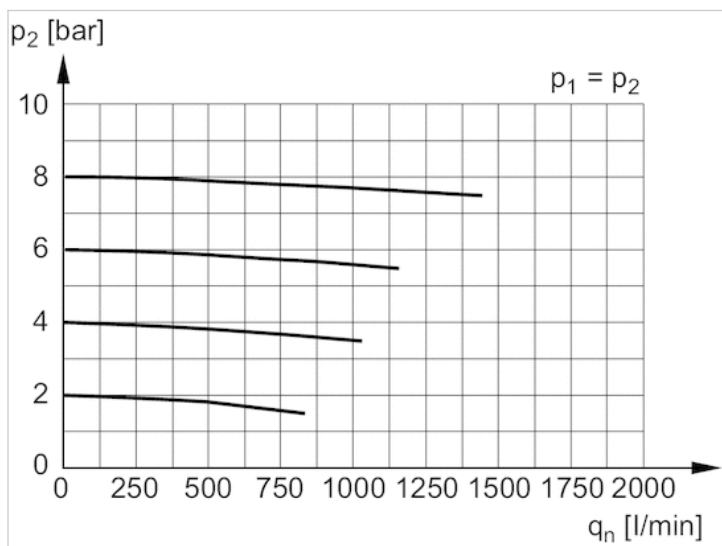

p_1 = Working pressure

p_2 = Secondary pressure

q_n = Nominal flow

Accessories overview

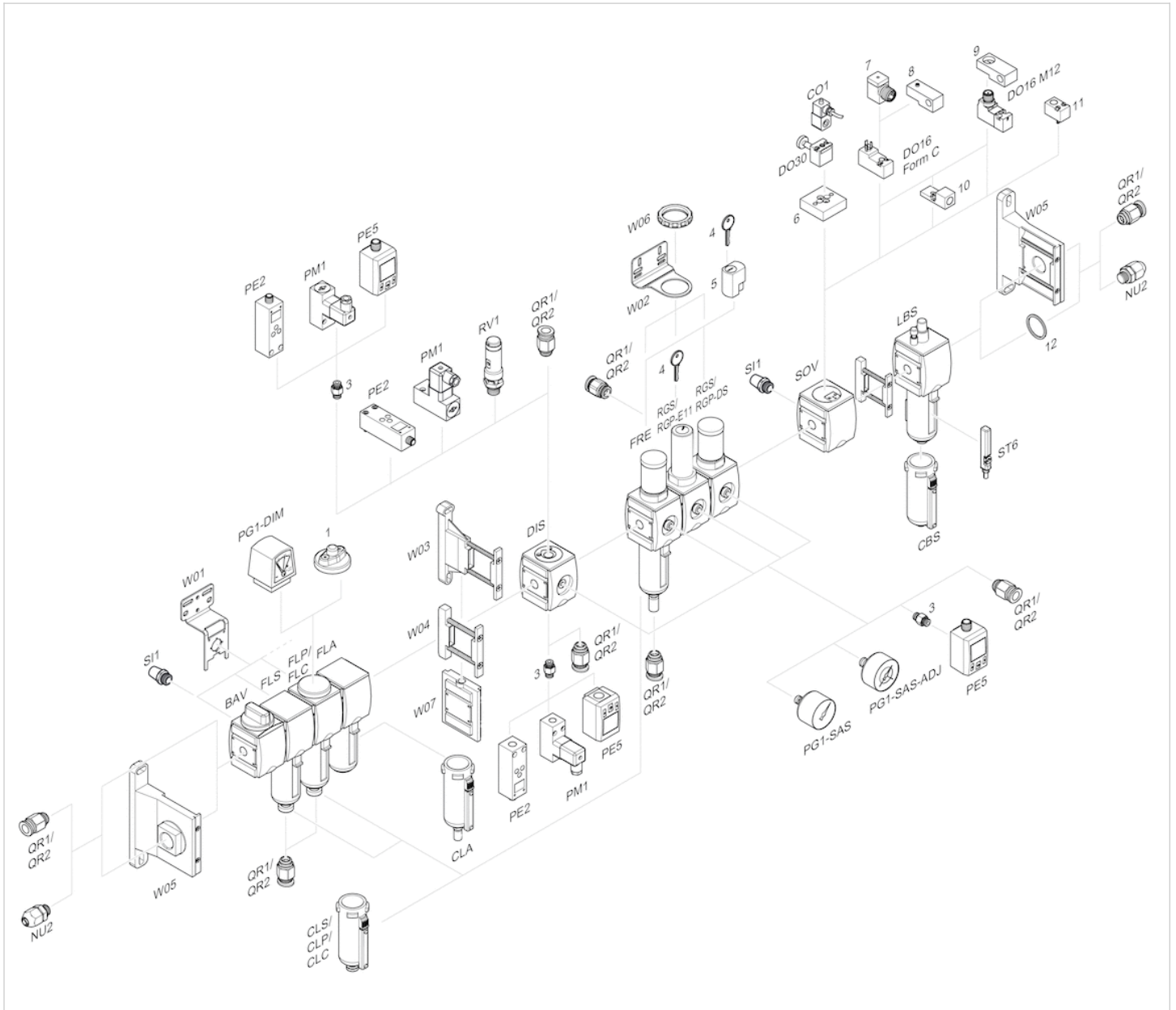

- 1 = contamination display
- 3 = Double nipple
- 4 = Key for E11 locking
- 5 = mortise lock
- 6 = Transition plate DO30
- 7 = Adapter, Series CON-VP
- 8 = Mounting aid DO16, form C
- 9 = Mounting aid DO16, M12
- 10 = Adapter for external pilot air
- 11 = Adapter pneumatic operation
- 12 = Sealing ring

Microfilter, Series AS2-FLC

- G 1/4 G 3/8
- filter porosity 0.01 µm
- contamination display integrated
- suitable for ATEX

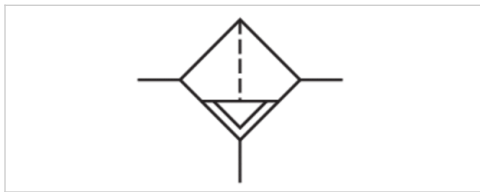

Version	Microfilter, Can be assembled into blocks
Parts	Microfilter
Mounting orientation	vertical
Certificates	suitable for ATEX
Working pressure min./max.	1.5 ... 16 bar
Ambient temperature min./max.	-10 ... 50 °C
Medium temperature min./max.	-10 ... 50 °C
Medium	Compressed air Neutral gases
Filter reservoir volume	12 cm ³
Filter element	exchangeable
filter porosity	0.01 µm
Condensate drain	See table below
contamination display	integrated
Weight	See table below

Technical data

Part No.	Port	Flow Qn	Condensate drain
R412006054	G 1/4	350 l/min	semi-automatic, open without pressure
R412006055	G 1/4	350 l/min	fully automatic, open without pressure
R412006056	G 1/4	350 l/min	fully automatic, closed without pressure
R412006060	G 1/4	350 l/min	semi-automatic, open without pressure
R412006061	G 1/4	350 l/min	fully automatic, open without pressure
R412006062	G 1/4	350 l/min	fully automatic, closed without pressure
R412006063	G 3/8	350 l/min	semi-automatic, open without pressure
R412006064	G 3/8	350 l/min	fully automatic, open without pressure
R412006065	G 3/8	350 l/min	fully automatic, closed without pressure
R412006069	G 3/8	350 l/min	semi-automatic, open without pressure
R412006070	G 3/8	350 l/min	fully automatic, open without pressure
R412006071	G 3/8	350 l/min	fully automatic, closed without pressure

Part No.	Version	Weight	Fig.
R412006054	reservoir, polycarbonate, with PA protective guard	0.22 kg	Fig. 1
R412006055	reservoir, polycarbonate, with PA protective guard	0.263 kg	Fig. 2
R412006056	reservoir, polycarbonate, with PA protective guard	0.263 kg	Fig. 2
R412006060	-	0.485 kg	Fig. 1
R412006061	-	0.564 kg	Fig. 2
R412006062	-	0.569 kg	Fig. 2

Part No.	Version	Weight	Fig.
R412006063	reservoir, polycarbonate, with PA protective guard	0.22 kg	Fig. 3
R412006064	reservoir, polycarbonate, with PA protective guard	0.263 kg	Fig. 4
R412006065	reservoir, polycarbonate, with PA protective guard	0.263 kg	Fig. 4
R412006069	-	0.474 kg	Fig. 3
R412006070	-	0.554 kg	Fig. 4
R412006071	-	0.559 kg	Fig. 4

Nominal flow Q_n with secondary pressure $p_2 = 6$ bar at $\Delta p = 0.1$ bar

Suitable for use in Ex zones 1, 2, 21, 22.

Technical information

The pressure dew point must be at least 15 °C under ambient and medium temperature and may not exceed 3 °C .

Note: Polycarbonate reservoirs are susceptible to solvents, supplementary information can be found at "Customer information".

Suitable for use in Ex zones 1, 2, 21, 22.

A change in the flow direction (from air supply on the left to air supply on the right) occurs by rotating installation by 180° about the vertical axis. Please see the operating instructions for further details.

Recommended pre-filtering 0.3 µm

Max. achievable compressed air class acc. to ISO 8573-1:2010 1 : - : 2

Technical information

Material	
Housing	Polyamide
Front plate	Acrylonitrile butadiene styrene
Seals	Acrylonitrile butadiene rubber
Threaded bushing	Die cast zinc
Reservoir	Polycarbonate Die cast zinc
Protective guard	Polyamide
Filter insert	Borosilicate glass fiber

Dimensions

Dimensions in mm, Fig. 1

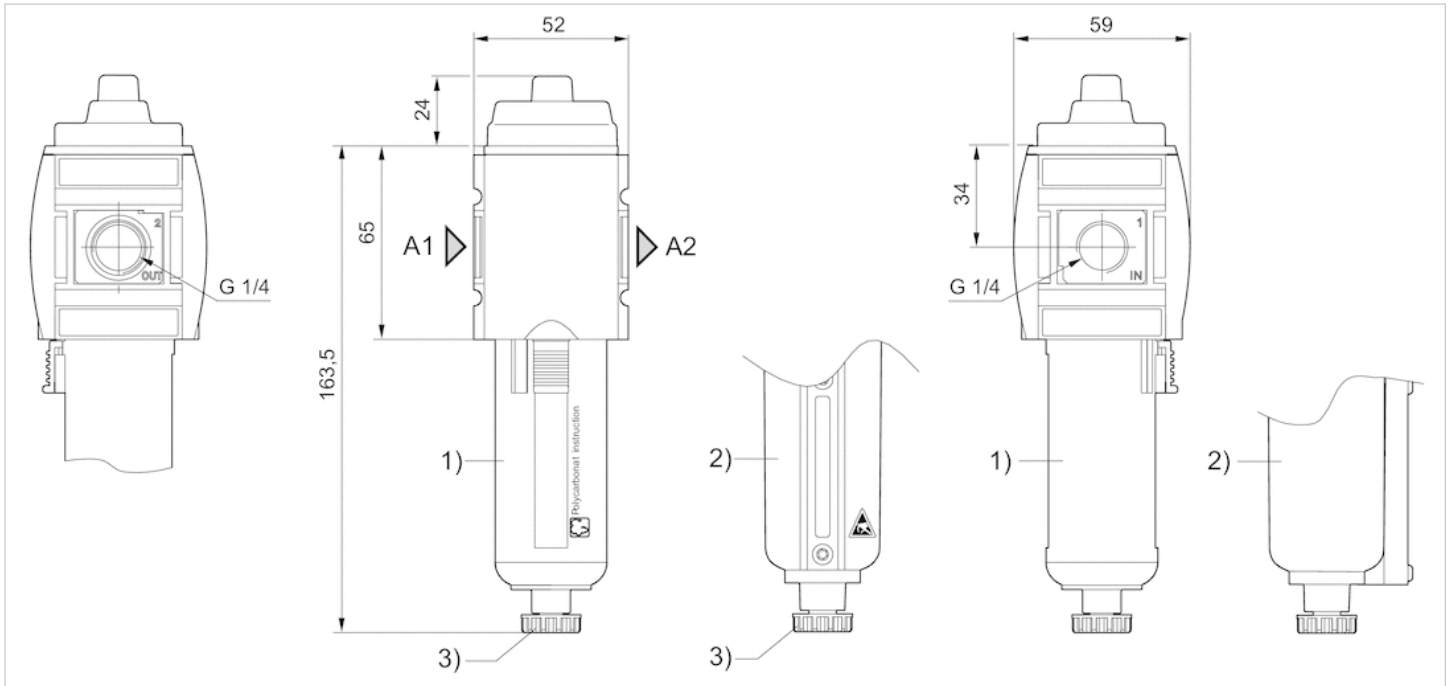

A1 = input

A2 = output

1) Plastic reservoir and protective guard with window

2) Metal reservoir with inspection glass

3) Semi-automatic condensate drain

Dimensions in mm, Fig. 2

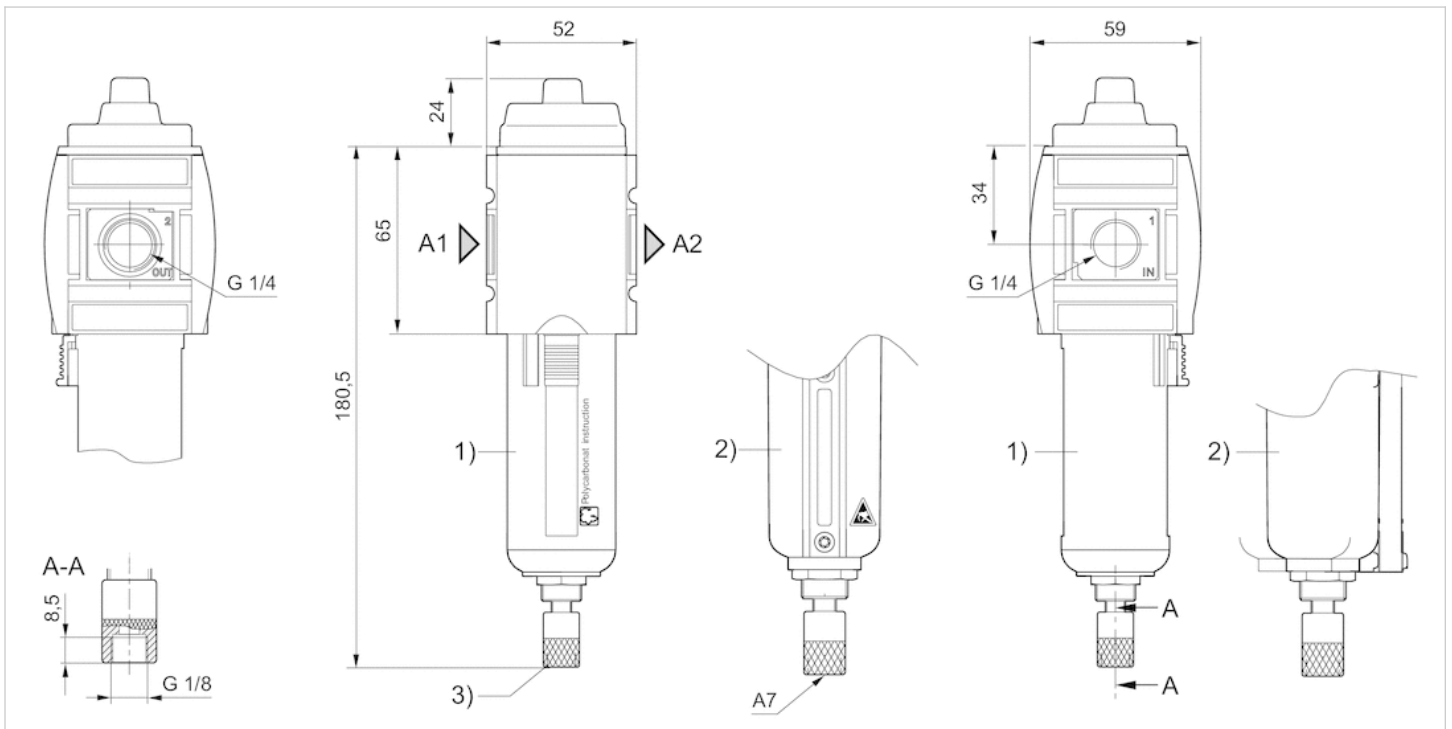

A1 = input

A2 = output

A7 = condensate drain

- 1) Plastic reservoir and protective guard with window
- 2) Metal reservoir with inspection glass
- 3) Fully automatic condensate drain

Dimensions in mm, Fig. 3

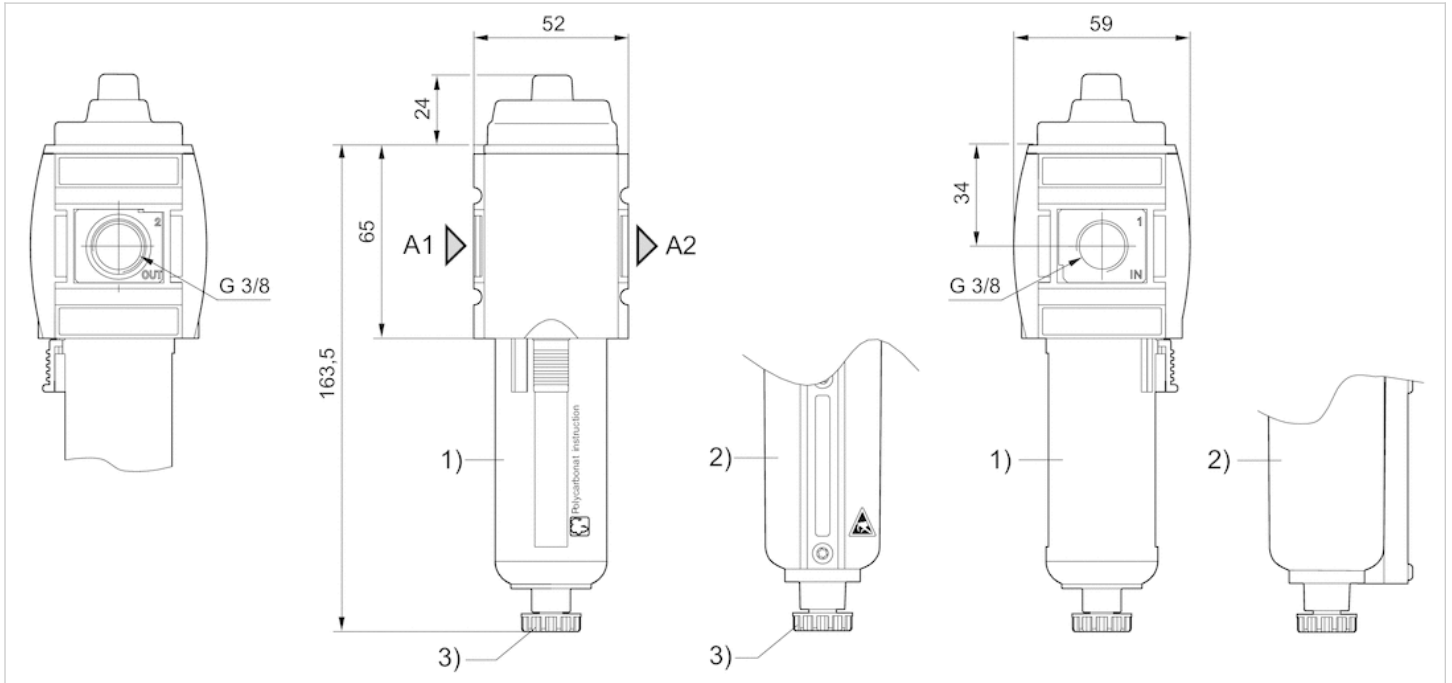

A1 = input

A2 = output

- 1) Plastic reservoir and protective guard with window
- 2) Metal reservoir with inspection glass
- 3) Semi-automatic condensate drain

Dimensions in mm, Fig. 4

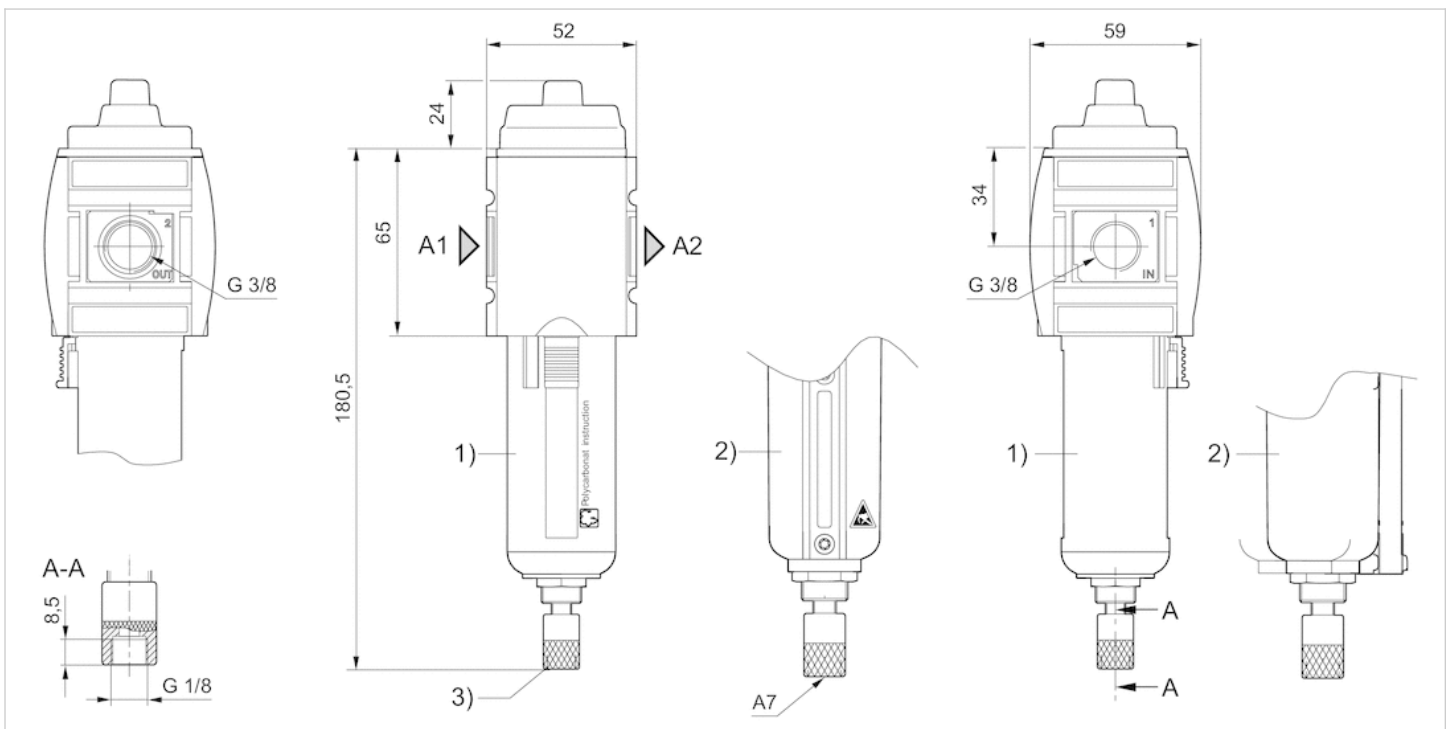

A1 = input

A2 = output

A7 = condensate drain

1) Plastic reservoir and protective guard with window

2) Metal reservoir with inspection glass

3) Fully automatic condensate drain

Diagrams

Flow rate characteristic

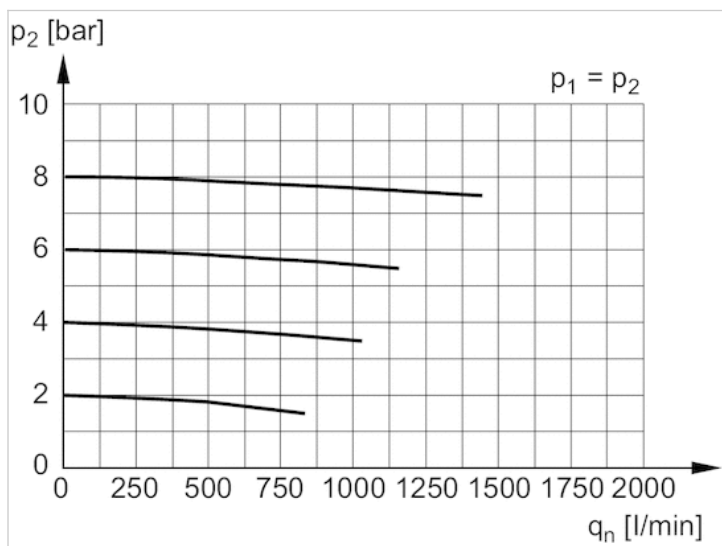

p_1 = Working pressure

p_2 = Secondary pressure

q_n = Nominal flow

Accessories overview

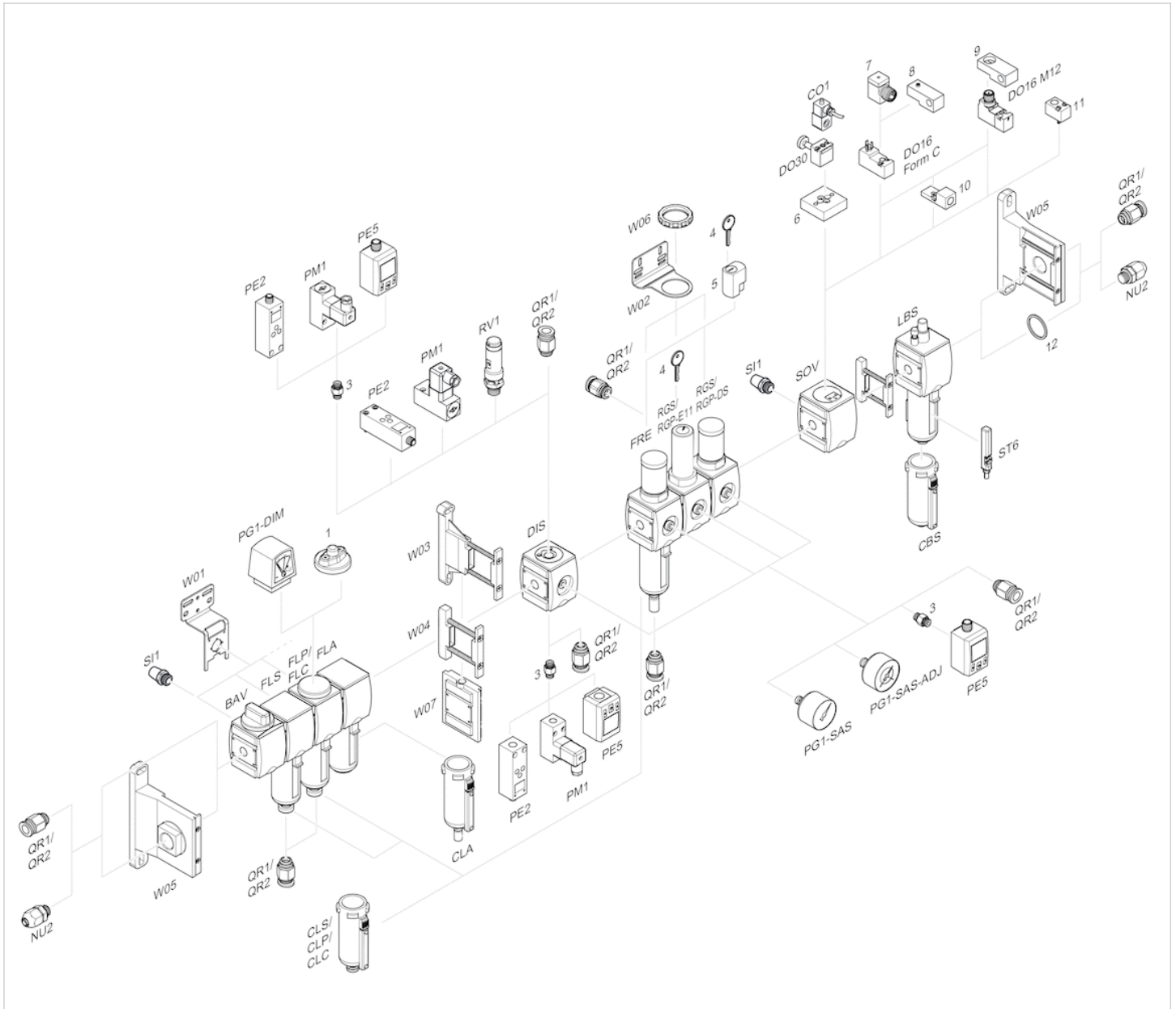

- 1 = contamination display
- 3 = Double nipple
- 4 = Key for E11 locking
- 5 = mortise lock
- 6 = Transition plate DO30
- 7 = Adapter, Series CON-VP
- 8 = Mounting aid DO16, form C
- 9 = Mounting aid DO16, M12
- 10 = Adapter for external pilot air
- 11 = Adapter pneumatic operation
- 12 = Sealing ring

Active carbon filter, Series AS2-FLA

- G 1/4 G 3/8

- suitable for ATEX

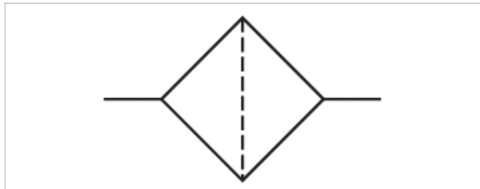

Version	Active carbon filter, Can be assembled into blocks
Parts	Active carbon filter
Mounting orientation	vertical
Certificates	suitable for ATEX
Working pressure min./max.	0 ... 16 bar
Ambient temperature min./max.	-10 ... 50 °C
Medium temperature min./max.	-10 ... 50 °C
Medium	Compressed air Neutral gases
Filter reservoir volume	12 cm ³
Filter element	exchangeable
Condensate drain	without
Weight	See table below

Technical data

Part No.	Port	Flow Qn	Version	Weight
R412006072	G 1/4	650 l/min	reservoir, polycarbonate, with PA protective guard	0.22 kg
R412006074	G 1/4	650 l/min	reservoir, metal, with inspection glass	0.454 kg
R412006075	G 3/8	650 l/min	reservoir, polycarbonate, with PA protective guard	0.22 kg
R412006077	G 3/8	650 l/min	reservoir, metal, with inspection glass	0.44 kg

Part No.	Fig.
R412006072	Fig. 1
R412006074	Fig. 2
R412006075	Fig. 3
R412006077	Fig. 4

Nominal flow Qn with secondary pressure p₂ = 6 bar at Δp = 0.1 bar

Suitable for use in Ex zones 1, 2, 21, 22.

Technical information

The pressure dew point must be at least 15 °C under ambient and medium temperature and may not exceed 3 °C .

Note: Polycarbonate reservoirs are susceptible to solvents, supplementary information can be found at "Customer information".

Suitable for use in Ex zones 1, 2, 21, 22.

A change in the flow direction (from air supply on the left to air supply on the right) occurs by rotating installation by 180° about the vertical axis. Please see the operating instructions for further details.

Recommended pre-filtering 0.01 μm

Max. achievable compressed air class acc. to ISO 8573-1:2010 - : - : 1

Technical information

Material	
Housing	Polyamide
Front plate	Acrylonitrile butadiene styrene
Seals	Acrylonitrile butadiene rubber
Threaded bushing	Die cast zinc
Reservoir	Polycarbonate Die cast zinc
Protective guard	Polyamide
Filter insert	Active carbon

Dimensions

Dimensions in mm, Fig. 1

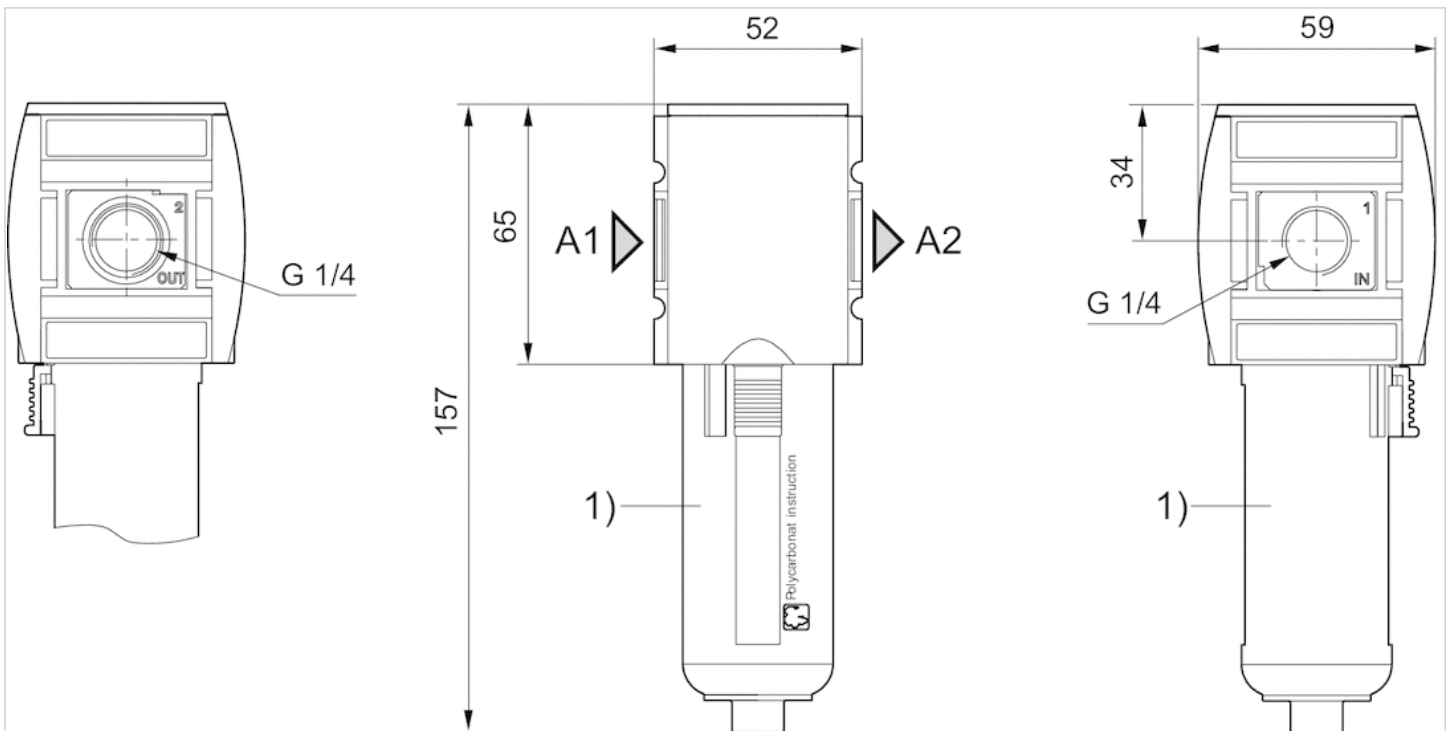

- A1 = input
- A2 = output
- 1) Plastic reservoir and protective guard with window

Dimensions in mm, Fig. 2

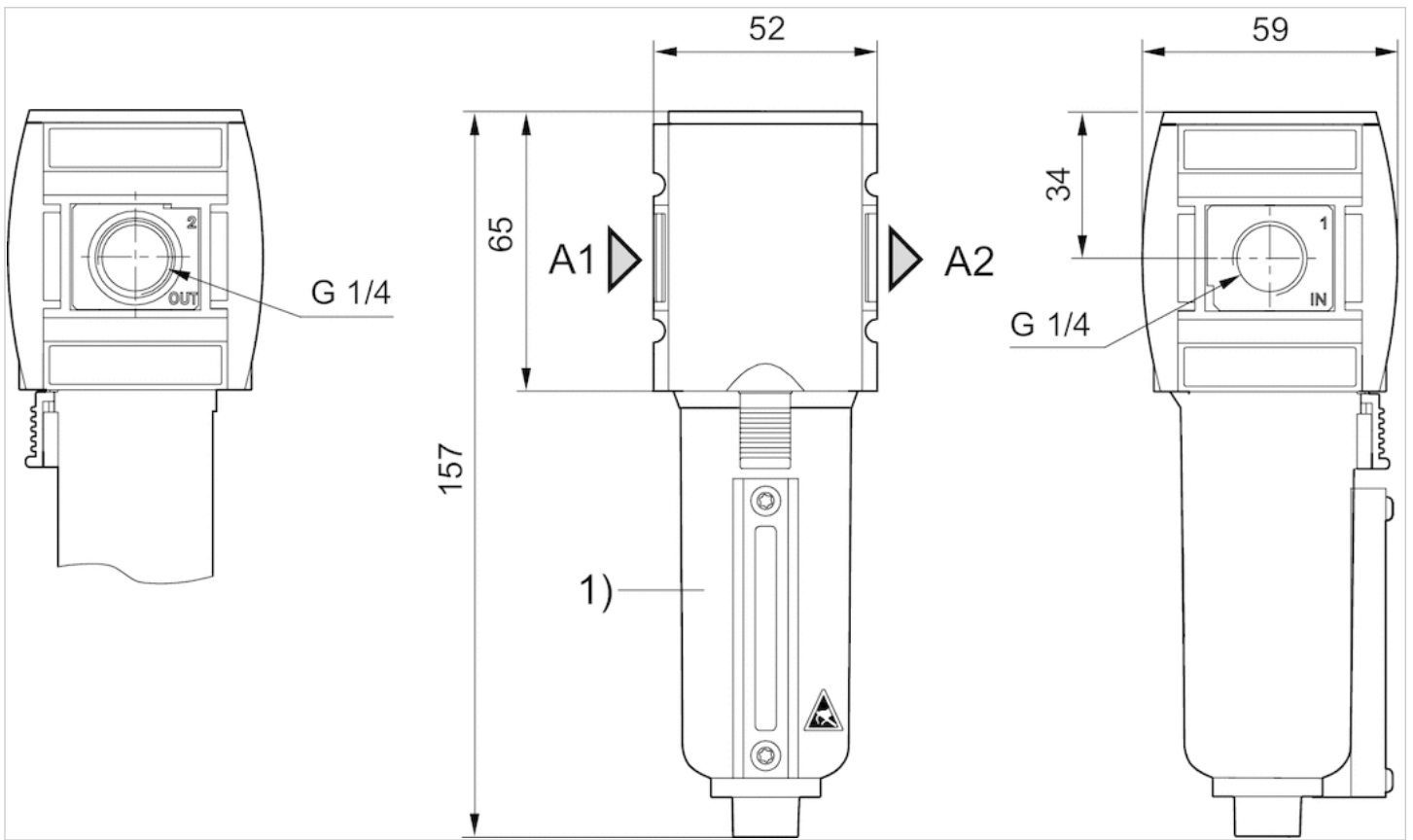

- A1 = input
- A2 = output
- 1) Metal reservoir with inspection glass

Dimensions in mm, Fig. 3

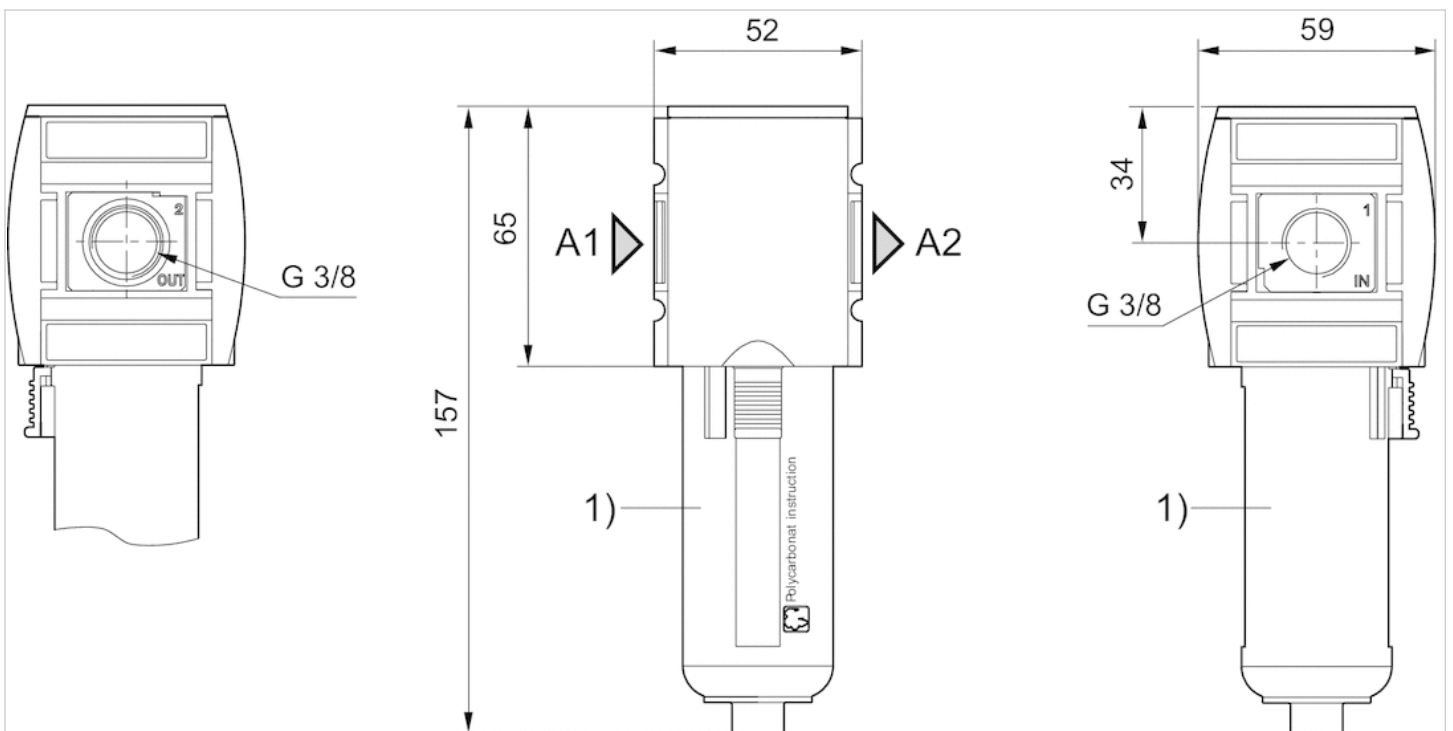

- A1 = input
- A2 = output

1) Plastic reservoir and protective guard with window

Dimensions in mm, Fig. 4

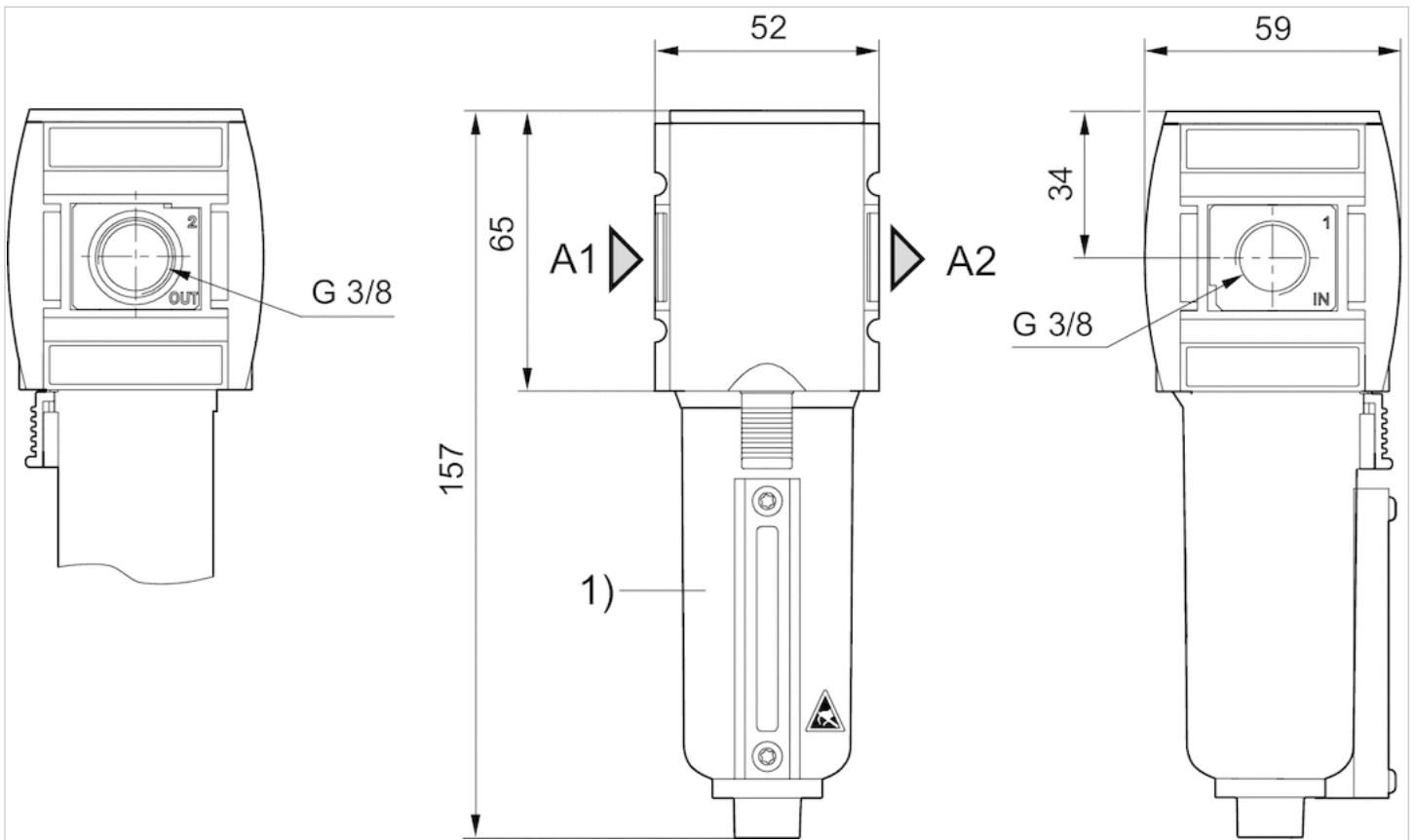

A1 = input

A2 = output

Metal reservoir with inspection glass

Diagrams

Flow rate characteristic

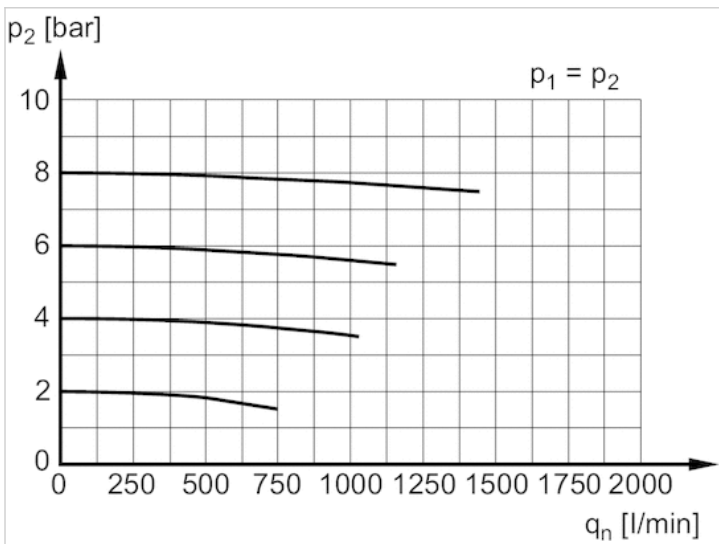

p_1 = Working pressure

p_2 = Secondary pressure

q_n = Nominal flow

Accessories overview

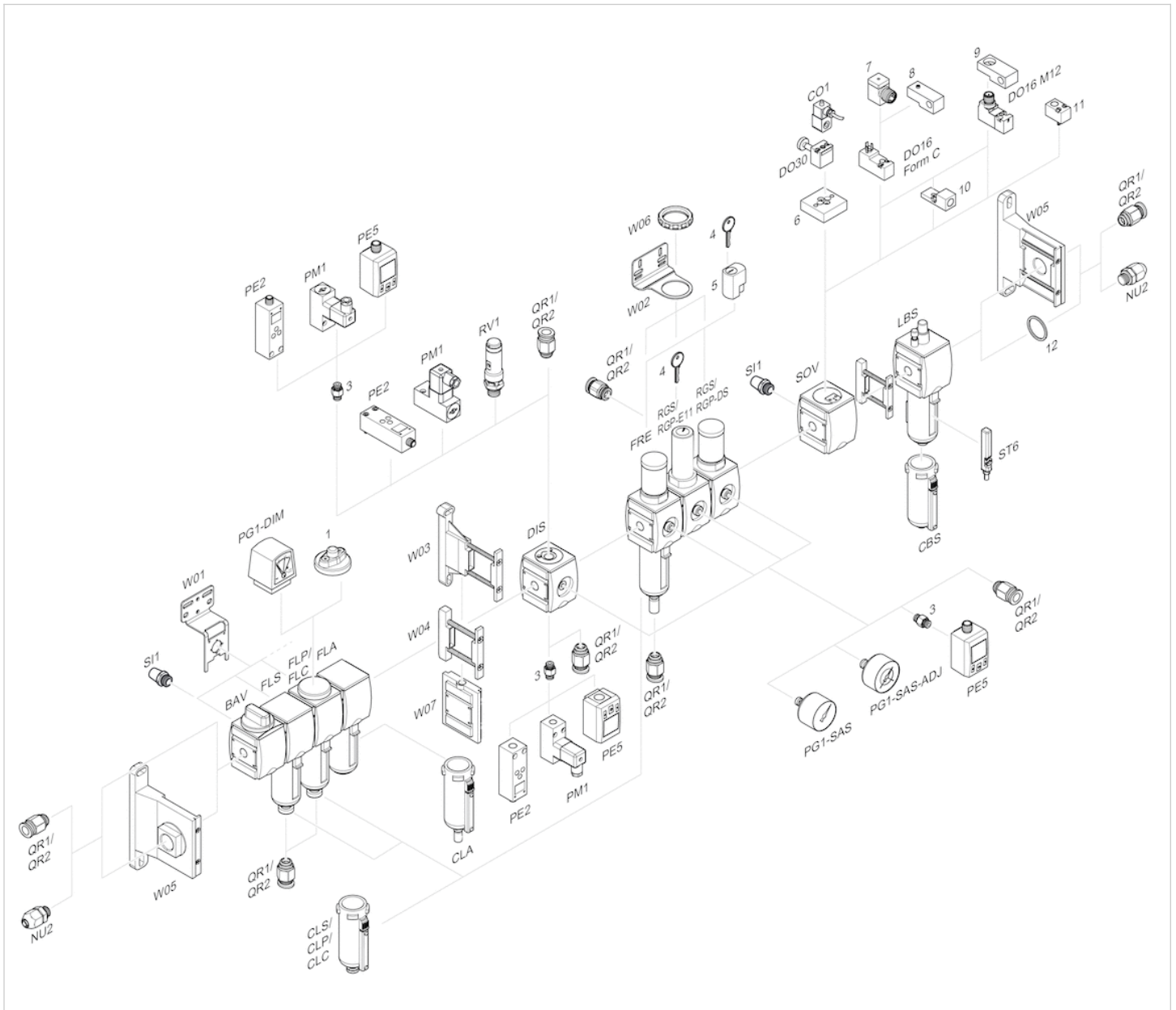

- 1 = contamination display
- 3 = Double nipple
- 4 = Key for E11 locking
- 5 = mortise lock
- 6 = Transition plate DO30
- 7 = Adapter, Series CON-VP
- 8 = Mounting aid DO16, form C
- 9 = Mounting aid DO16, M12
- 10 = Adapter for external pilot air
- 11 = Adapter pneumatic operation
- 12 = Sealing ring

Flow sensor, IO-Link, Series AF2

- 2 analog outputs, 2 switch outputs, 1 frequency output, 1 pulse output, IO-Link, With mounting
- Qn min. 5 l/min
- Qn max. 1590 l/min
- Electrical connection Plug, M12x1, 5-pin

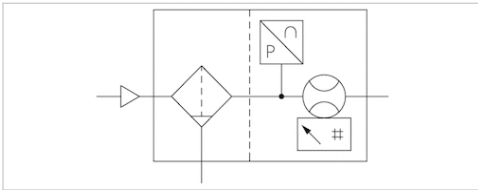

Certificates

Working pressure min./max.
Ambient temperature min./max.
Medium temperature min./max.
Medium

filter porosity

Display

Flow display unit

Pressure display unit

Temperature display unit

DC operating voltage min.

DC operating voltage max.

Max. power consumption *)

Response time

Protection class

Short circuit resistance

Shock resistance max.

Vibration resistance

Reproducibility

Weight

*)

CE declaration of conformity RoHS UL
(Underwriters Laboratories)

0 ... 16 bar

-20 ... 60 °C

-20 ... 60 °C

Compressed air Argon Nitrogen Helium
Carbon dioxide

5 µm

OLED

l/sec, l/min, m³/min, m³/h, ft³/s, m³/min

bar, psi

°C, °F

17 V DC

30 V DC

175 mA

10 ms

IP65, IP67 according to IEC 60529

short circuit resistant

30 g, 11 ms

1 g (10 - 2000 Hz) IEC 60068 - 2-6

± 1.5% of the measured value

1.23 kg

Current consumption without load

Technical data

Part No.	for series	Compressed air connection	Nominal flow Qn	Nominal flow Qn	Nominal flow Qn
			Min., standard	Max., standard	Min., extended
R412026834	AS2	G 3/8	5 l/min	1060 l/min	1060 l/min

Part No.	Nominal flow Qn
	Max., extended
R412026834	1590 l/min

Standard measurement range for flow measurement: compressed air 0.5 ... 100 m/s, extended measurement range: compressed air >100 ... 150 m/s, in accordance with ISO 8778, Flow display range: 0 ... 3180 l/min

Technical information

The pressure dew point must be at least 15 °C under ambient and medium temperature and may not exceed 3 °C .
 The protection class is only ensured when the plug is mounted properly. For detailed information, see operating instructions.
 The device is designed to be installed in AS series air preparation units or to be fitted as a stand-alone device using a W05 block assembly kit.
 Liquid oil or water must be separated via prefiltering. If it is not separated sufficiently, drifting may result.
 Precision- Standard measurement range: ±3% of measured value, + 0.3% of final value- Extended measurement range: ±8% of measured value, + 1% of final value
 The IO-Link device description (IODD) for the AF2 flow rate sensor is available for download in the Media Center.

Technical information

Material	
Housing	Polyamide, Polycarbonate
Seals	Fluorocaoutchouc

Dimensions

Dimensions in mm

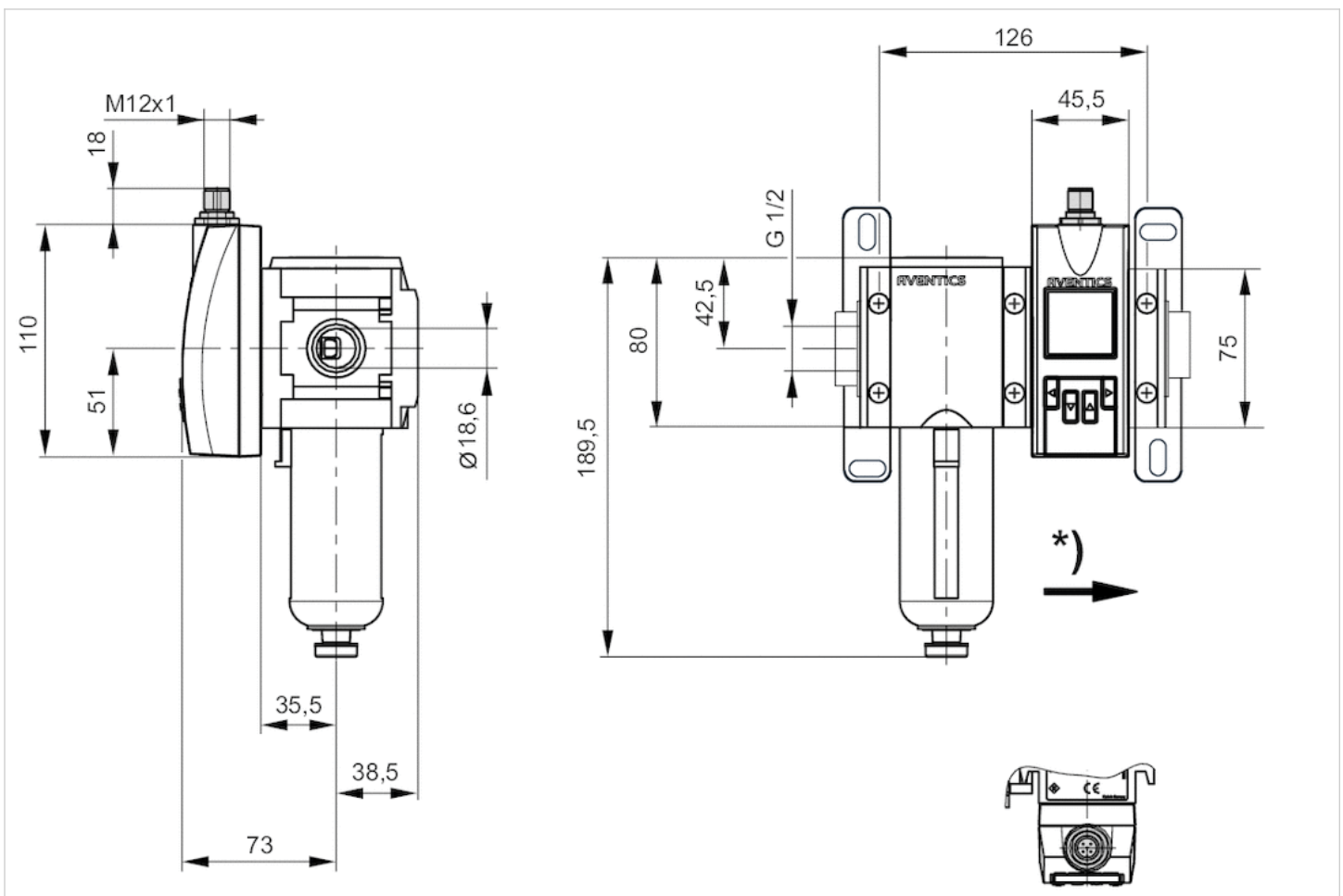

* Flow direction

Pin assignments

Pin assignments, M12x1, 5-pin

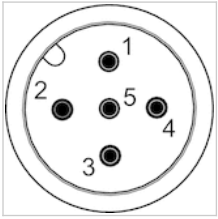

Pin	1	2	3
Allocation	L+	QA (output 4 ... 20 mA)	m = mass
	4	5	
	C/Q1 (IO-Link/switch output)	Analog output 4 ... 20 mA	

Flow sensor, Ethernet, Series AF2

- Ethernet, With mounting
- Qn min. 5 l/min
- Qn max. 1590 l/min
- Electrical connection Plug, M12x1, 8-pin

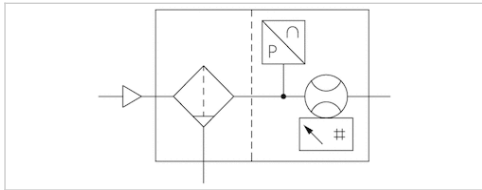

Certificates	CE declaration of conformity RoHS UL (Underwriters Laboratories)
Working pressure min./max.	0 ... 16 bar
Ambient temperature min./max.	-20 ... 60 °C
Medium temperature min./max.	-20 ... 60 °C
Medium	Compressed air Argon Nitrogen Helium Carbon dioxide
filter porosity	5 µm
Display	OLED
Flow display unit	l/sec, l/min, m³/min, m³/h, ft³/s, m³/min
Pressure display unit	bar, psi
Temperature display unit	°C, °F
DC operating voltage max.	45 V DC
Power consumption max.	12 W
Response time	10 ms
Protection class	IP65, IP67 according to IEC 60529
Shock resistance max.	30 g, 11 ms
Vibration resistance	1 g (10 - 2000 Hz) IEC 60068 - 2-6
Reproducibility	± 1.5% of the measured value
Weight	1.23 kg

Technical data

Part No.	for series	Compressed air connection	Nominal flow Qn	
			Min., standard	Max., standard
R412026837	AS2	G 3/8	5 l/min	1060 l/min

Part No.	Nominal flow Qn
	Max., extended
R412026837	1590 l/min

Standard measurement range for flow measurement: compressed air 0.5 ... 100 m/s, extended measurement range: compressed air >100 ... 150 m/s, in accordance with ISO 8778, Flow display range: 0 ... 3180 l/min

Technical information

The pressure dew point must be at least 15 °C under ambient and medium temperature and may not exceed 3 °C .
 The protection class is only ensured when the plug is mounted properly. For detailed information, see operating instructions.
 The device is designed to be installed in AS series air preparation units or to be fitted as a stand-alone device using a W05 block assembly kit.
 Liquid oil or water must be separated via prefiltering. If it is not separated sufficiently, drifting may result.
 Precision- Standard measurement range: ±3% of measured value, + 0.3% of final value- Extended measurement range: ±8% of measured value, + 1% of final value

Technical information

Material	
Housing	Polyamide, Polycarbonate
Seals	Fluorocaoutchouc

Dimensions

Dimensions in mm

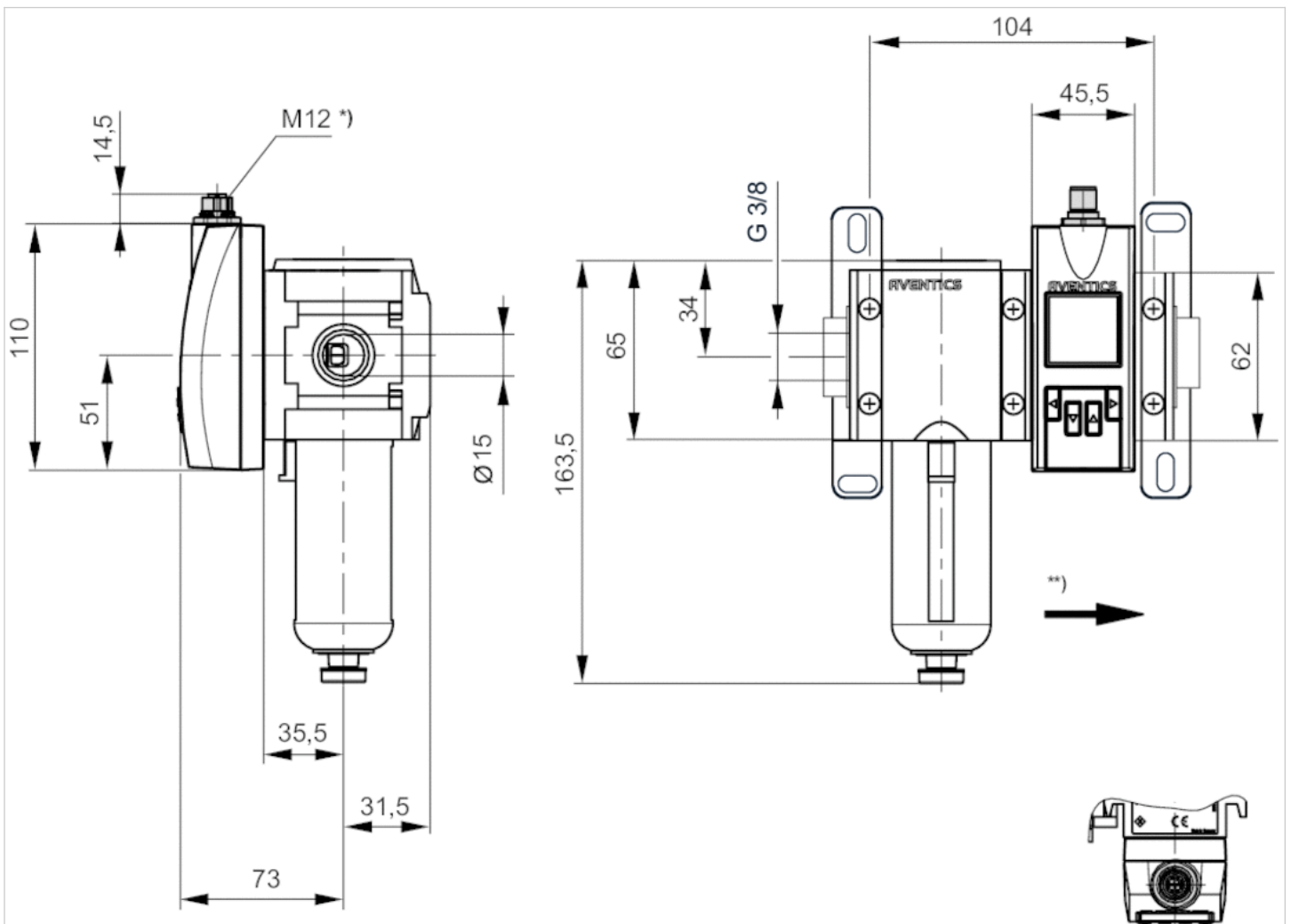

* Internal thread

** Flow direction

Pin assignments

Pin assignments, M12, X-coded

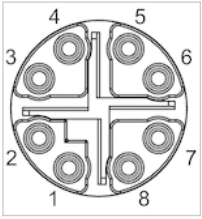

Pin	1	2	3	4	7	8	5
Color	WH / OG	OG	WH / GN	GN	WH / BU	BU	WH / BN
Function	TX(+) + POE	TX(-) + POE	RX(+) - POE	RX(-) - POE	POE+	POE+	POE-

							6
							BN
							POE-

Flow sensor, IO-Link, Series AF2

- 2 analog outputs, 2 switch outputs, 1 frequency output, 1 pulse output, IO-Link, Without mounting
- Qn min. 5 l/min
- Qn max. 1590 l/min
- Electrical connection Plug, M12x1, 5-pin

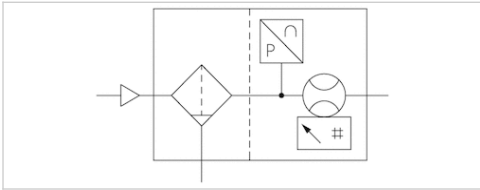

Certificates

Working pressure min./max.

Ambient temperature min./max.

Medium temperature min./max.

Medium

filter porosity

Display

Flow display unit

Pressure display unit

Temperature display unit

DC operating voltage min.

DC operating voltage max.

Max. power consumption *)

Response time

Protection class

Short circuit resistance

Shock resistance max.

Vibration resistance

Reproducibility

Weight

*)

CE declaration of conformity RoHS UL
(Underwriters Laboratories)

0 ... 16 bar

-20 ... 60 °C

-20 ... 60 °C

Compressed air Argon Nitrogen Helium
Carbon dioxide

5 µm

OLED

l/sec, l/min, m³/min, m³/h, ft³/s, m³/min

bar, psi

°C, °F

17 V DC

30 V DC

175 mA

10 ms

IP65, IP67 according to IEC 60529

short circuit resistant

30 g, 11 ms

1 g (10 - 2000 Hz) IEC 60068 - 2-6

± 1.5% of the measured value

0.85 kg

Current consumption without load

Technical data

Part No.	for series	Compressed air connection	Nominal flow Qn	Nominal flow Qn	Nominal flow Qn
			Min., standard	Max., standard	Min., extended
R412027176	AS2	G 3/8	5 l/min	1060 l/min	1060 l/min

Part No.	Nominal flow Qn
	Max., extended
R412027176	1590 l/min

Standard measurement range for flow measurement: compressed air 0.5 ... 100 m/s, extended measurement range: compressed air >100 ... 150 m/s, in accordance with ISO 8778, Flow display range: 0 ... 3180 l/min

Technical information

The pressure dew point must be at least 15 °C under ambient and medium temperature and may not exceed 3 °C .
 The protection class is only ensured when the plug is mounted properly. For detailed information, see operating instructions.
 The device is designed to be installed in AS series air preparation units or to be fitted as a stand-alone device using a W05 block assembly kit.
 Liquid oil or water must be separated via prefiltering. If it is not separated sufficiently, drifting may result.
 Precision- Standard measurement range: ±3% of measured value, + 0.3% of final value- Extended measurement range: ±8% of measured value, + 1% of final value
 The IO-Link device description (IODD) for the AF2 flow rate sensor is available for download in the Media Center.

Technical information

Material	
Housing	Polyamide, Polycarbonate
Seals	Fluorocaoutchouc

Dimensions

Dimensions in mm

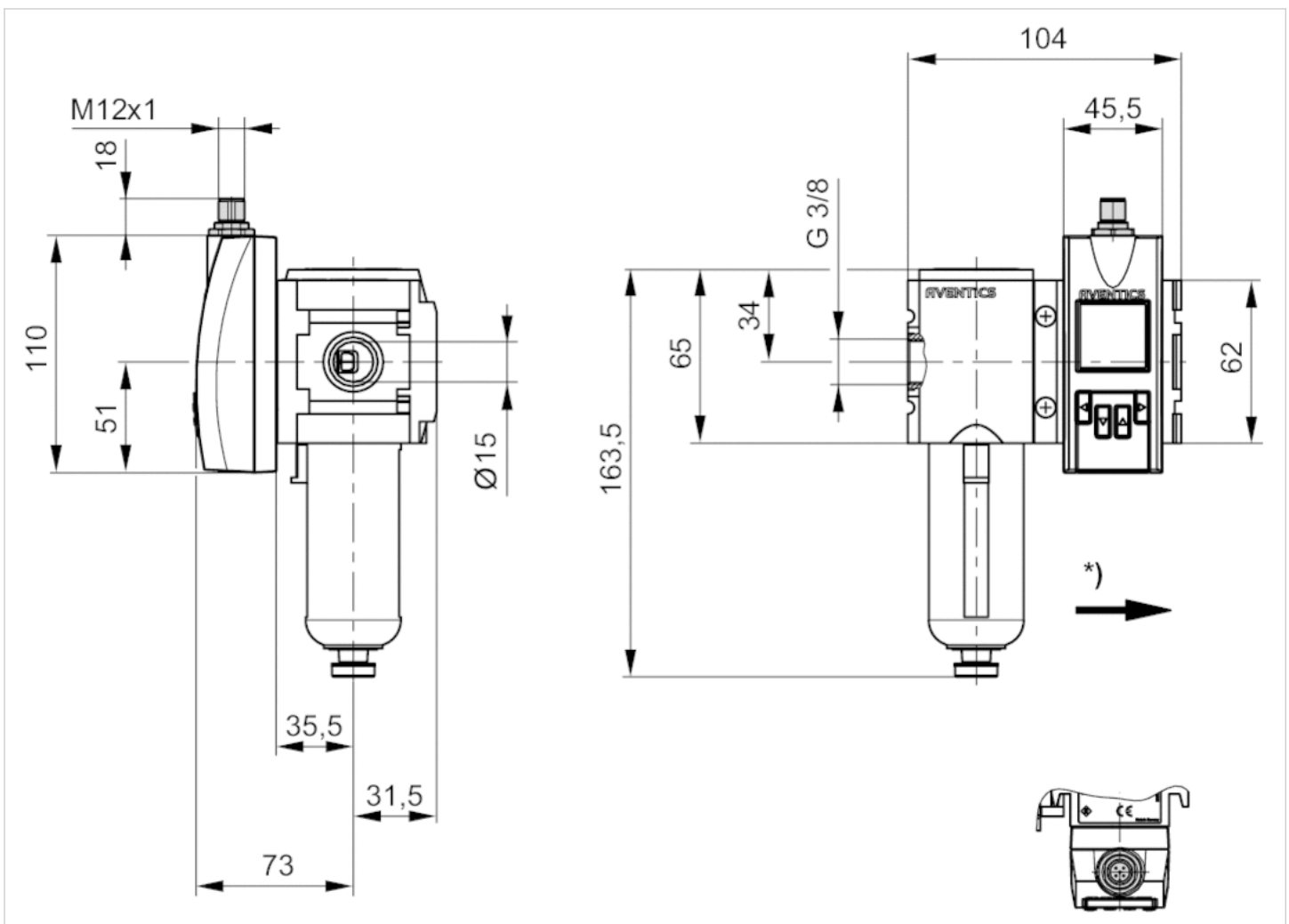

* Flow direction

Pin assignments

Pin assignments, M12x1, 5-pin

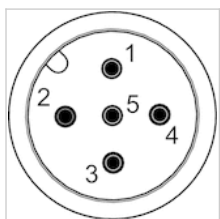

Pin	1	2	3
Allocation	L+	QA (output 4 ... 20 mA)	m = mass
	4	5	
	C/Q1 (IO-Link/switch output)	Analog output 4 ... 20 mA	

Flow sensor, Ethernet, Series AF2

- Ethernet, Without mounting
- Qn min. 5 l/min
- Qn max. 1590 l/min
- Electrical connection Plug, M12x1, 8-pin

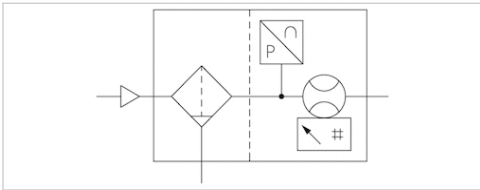

Certificates

Working pressure min./max.	0 ... 16 bar
Ambient temperature min./max.	-20 ... 60 °C
Medium temperature min./max.	-20 ... 60 °C
Medium	Compressed air Argon Nitrogen Helium Carbon dioxide
filter porosity	5 µm
Display	OLED
Flow display unit	l/sec, l/min, m³/min, m³/h, ft³/s, m³/min
Pressure display unit	bar, psi
Temperature display unit	°C, °F
DC operating voltage max.	45 V DC
Power consumption max.	12 W
Response time	10 ms
Protection class	IP65, IP67 according to IEC 60529
Shock resistance max.	30 g, 11 ms
Vibration resistance	1 g (10 - 2000 Hz) IEC 60068 - 2-6
Reproducibility	± 1.5% of the measured value
Weight	0.85 kg

Technical data

Part No.	for series	Compressed air connection	Nominal flow Qn	
			Min., standard	Max., standard
R412027179	AS2	G 3/8	5 l/min	1060 l/min

Part No.	Nominal flow Qn
	Max., extended
R412027179	1590 l/min

Standard measurement range for flow measurement: compressed air 0.5 ... 100 m/s, extended measurement range: compressed air >100 ... 150 m/s, in accordance with ISO 8778, Flow display range: 0 ... 3180 l/min

Technical information

The pressure dew point must be at least 15 °C under ambient and medium temperature and may not exceed 3 °C .

The protection class is only ensured when the plug is mounted properly. For detailed information, see operating instructions.

The device is designed to be installed in AS series air preparation units or to be fitted as a stand-alone device using a W05 block assembly kit.

Liquid oil or water must be separated via prefiltering. If it is not separated sufficiently, drifting may result.

Precision- Standard measurement range: ±3% of measured value, + 0.3% of final value- Extended measurement range: ±8% of measured value, + 1% of final value

Technical information

Material

Housing	Polyamide, Polycarbonate
Seals	Fluorocaoutchouc

Dimensions

Dimensions in mm

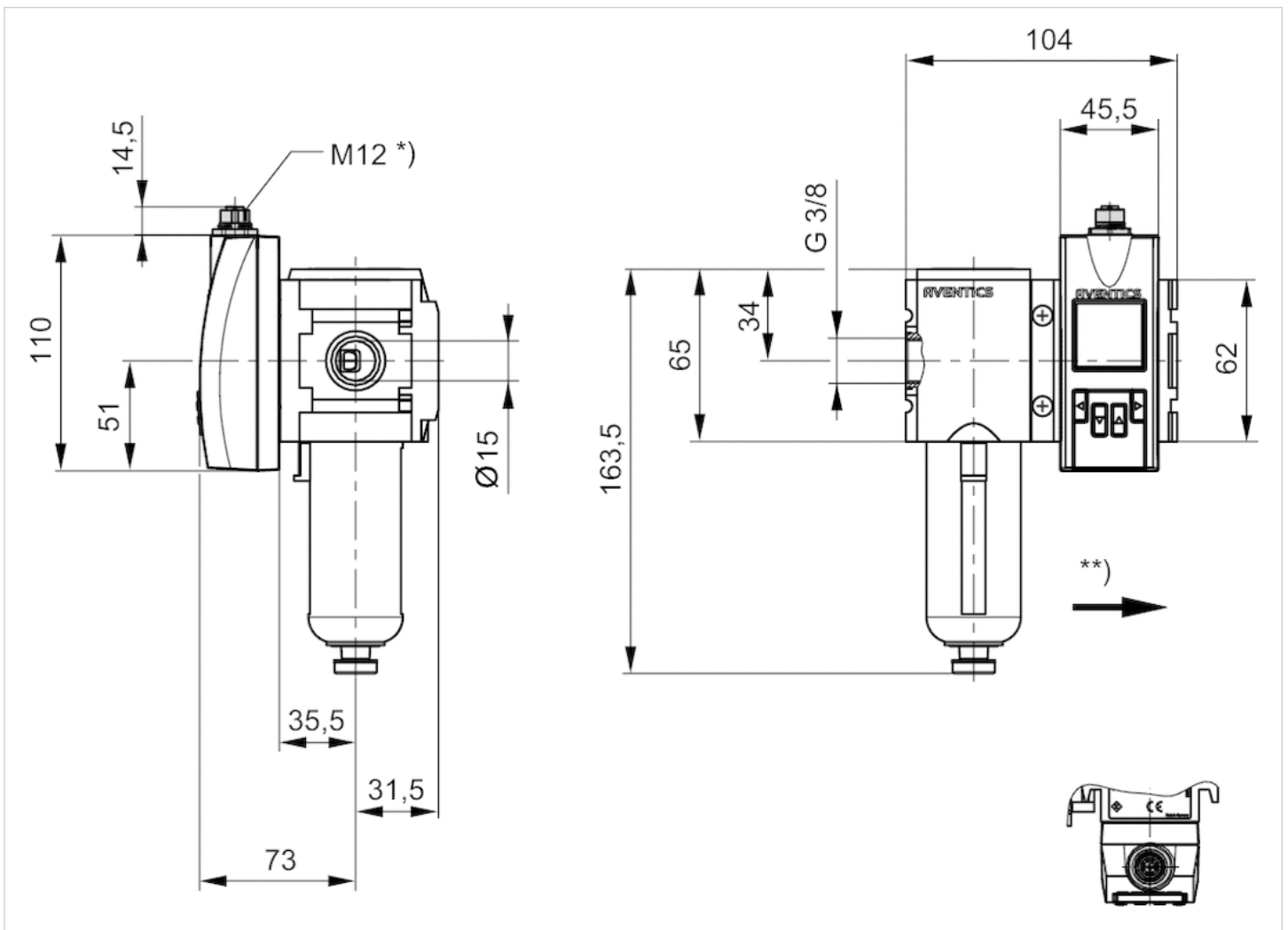

* Internal thread

** Flow direction

Pin assignments

Pin assignments, M12, X-coded

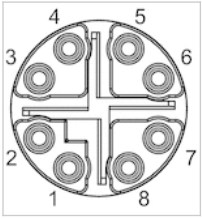

Pin	1	2	3	4	7	8	5
Color	WH / OG	OG	WH / GN	GN	WH / BU	BU	WH / BN
Function	TX(+) + POE	TX(-) + POE	RX(+) - POE	RX(-) - POE	POE+	POE+	POE-

							6
							BN
							POE-

Diaphragm-type dryer, Series AS2-ADD

- G 3/8

- suitable for ATEX

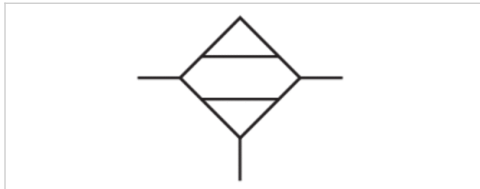

Version	Diaphragm-type dryer
Parts	Diaphragm-type dryer
Mounting orientation	vertical
Certificates	suitable for ATEX
Working pressure min./max.	4 ... 12.5 bar
Ambient temperature min./max.	2 ... 50 °C
Medium temperature min./max.	2 ... 50 °C
Medium	Compressed air Neutral gases
Filter element	not exchangeable
Lowering pressure dew point	20 °C
Weight	See table below

Technical data

Part No.	Port	Flow	Reservoir	Weight	Fig.	
		Qn				
R412006078	G 3/8	50 l/min	Aluminum	0.48 kg	Fig. 1	1)
R412006079	G 3/8	100 l/min	Aluminum	0.57 kg	Fig. 2	1)
R412006080	G 3/8	150 l/min	Aluminum	0.69 kg	Fig. 3	1)
R412006081	G 3/8	200 l/min	Aluminum	0.7 kg	Fig. 4	1)
R412006082	G 3/8	300 l/min	Aluminum	1.43 kg	Fig. 5	2)
R412006083	G 3/8	400 l/min	Aluminum	1.73 kg	Fig. 6	2)

1) Suitable for use in Ex zones 1, 2, 21, 22.

2) incl. distributor, Suitable for use in Ex zones 1, 2, 21, 22.

Technical information

The pressure dew point must be at least 15 °C under ambient and medium temperature and may not exceed 3 °C .

Notice: air may not contain condensate
 purge air approx. 12% of nominal flow Qn
 Suitable for use in Ex zones 1, 2, 21, 22.

A change in the flow direction (from air supply on the left to air supply on the right) occurs by rotating installation by 180° about the vertical axis. Please see the operating instructions for further details.

Recommended pre-filtering μm 5
 0.01 μm

Technical information

Material	
Housing	Polyamide
Front plate	Acrylonitrile butadiene styrene
Seal	Acrylonitrile butadiene rubber
Threaded bushing	Die cast zinc
Reservoir	Aluminum

Dimensions

Dimensions in mm, Fig. 1

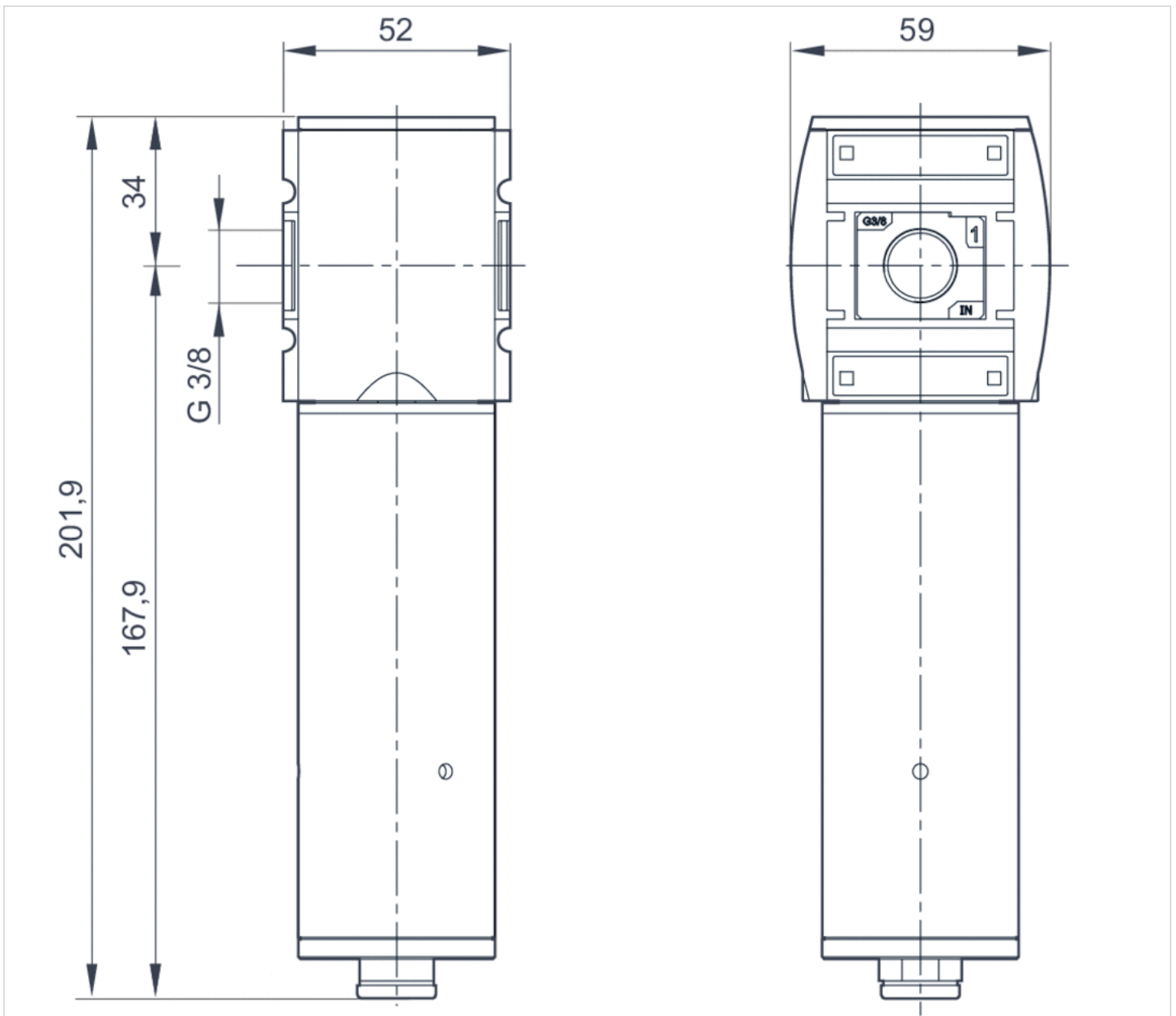

Dimensions in mm, Fig. 2

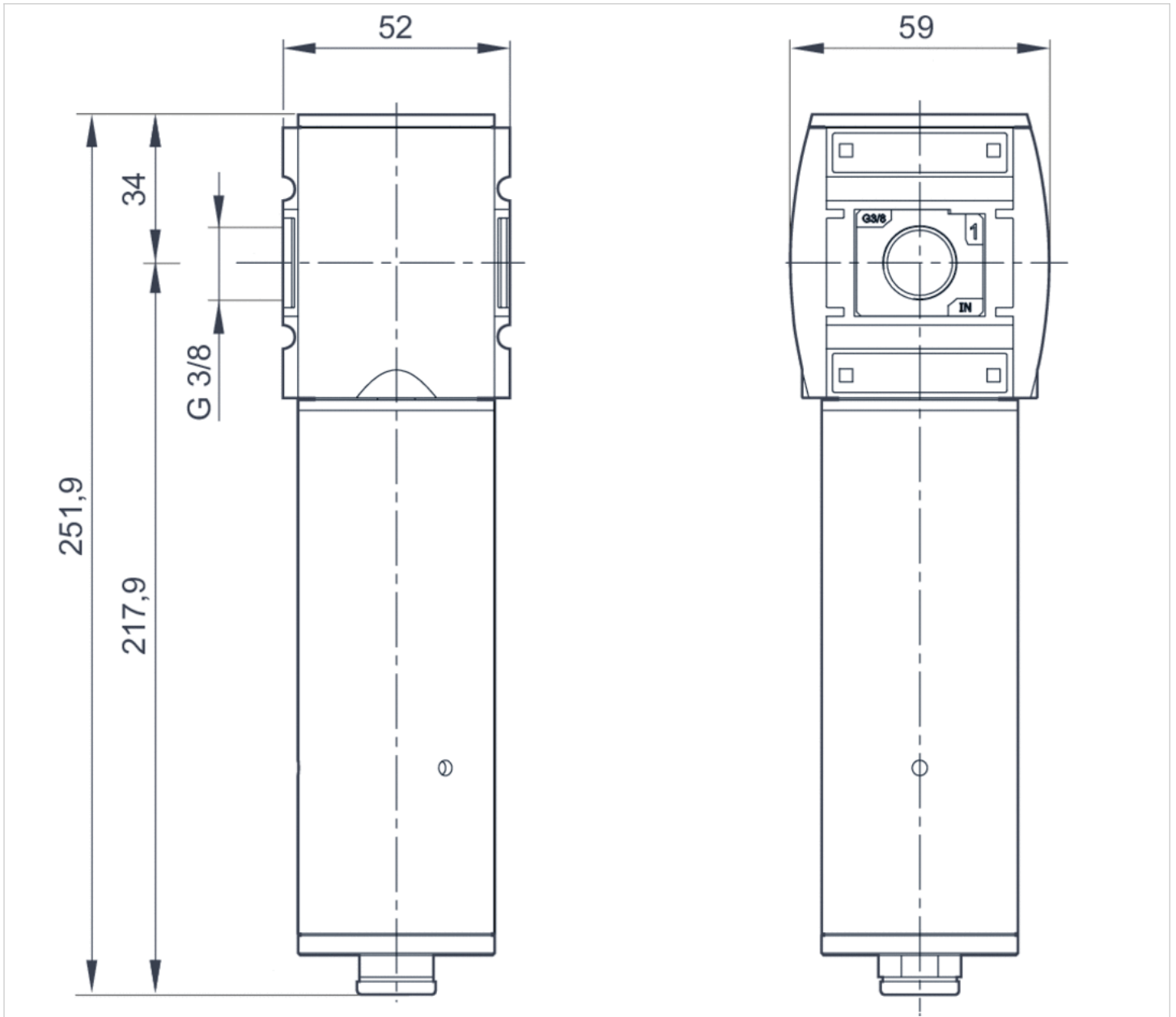

Dimensions in mm, Fig. 3

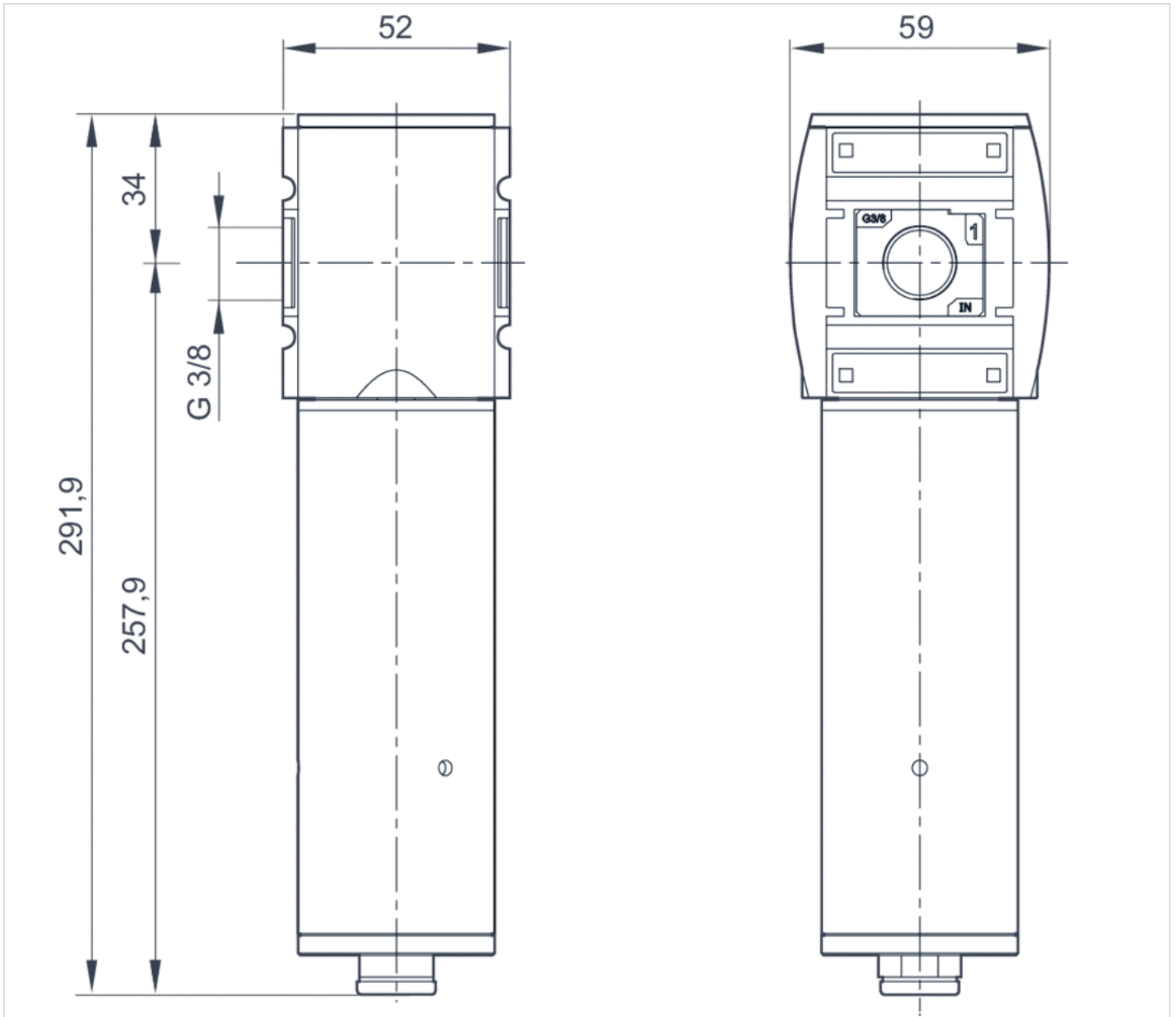

Dimensions in mm, Fig. 4

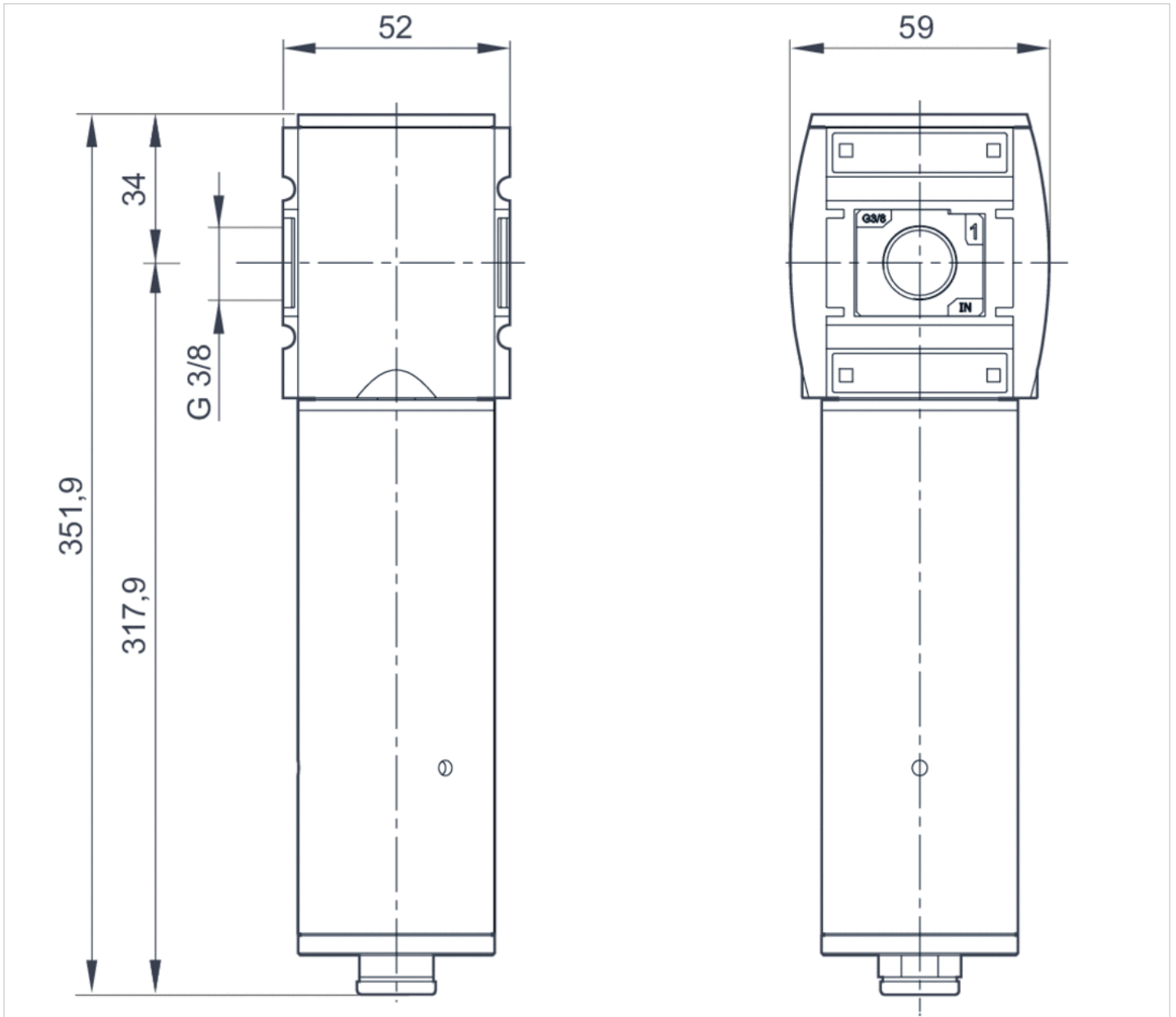

Dimensions in mm, Fig. 5

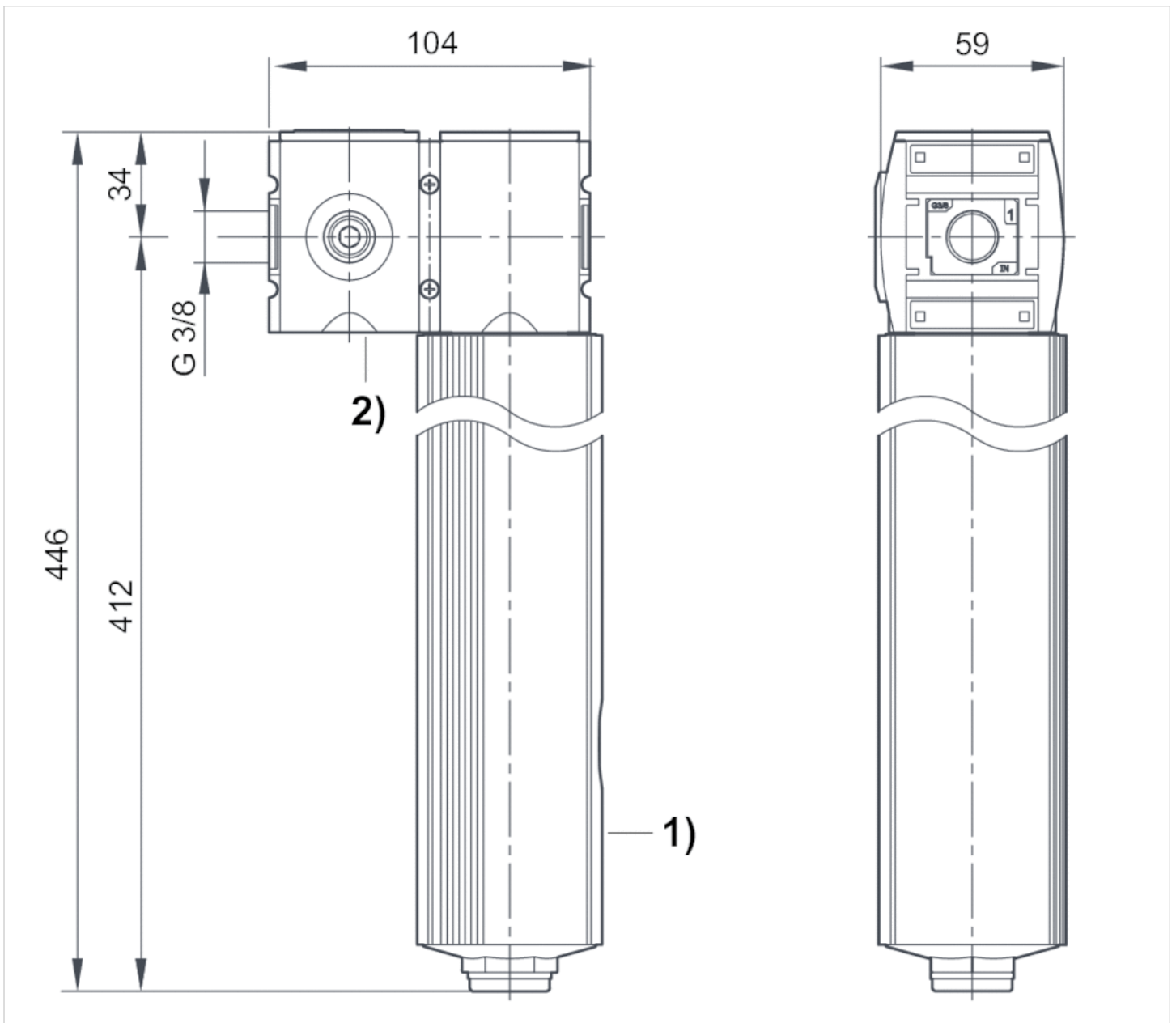

- 1) Diaphragm-type dryer
- 2) Incl. second distributor

Dimensions in mm, Fig. 6

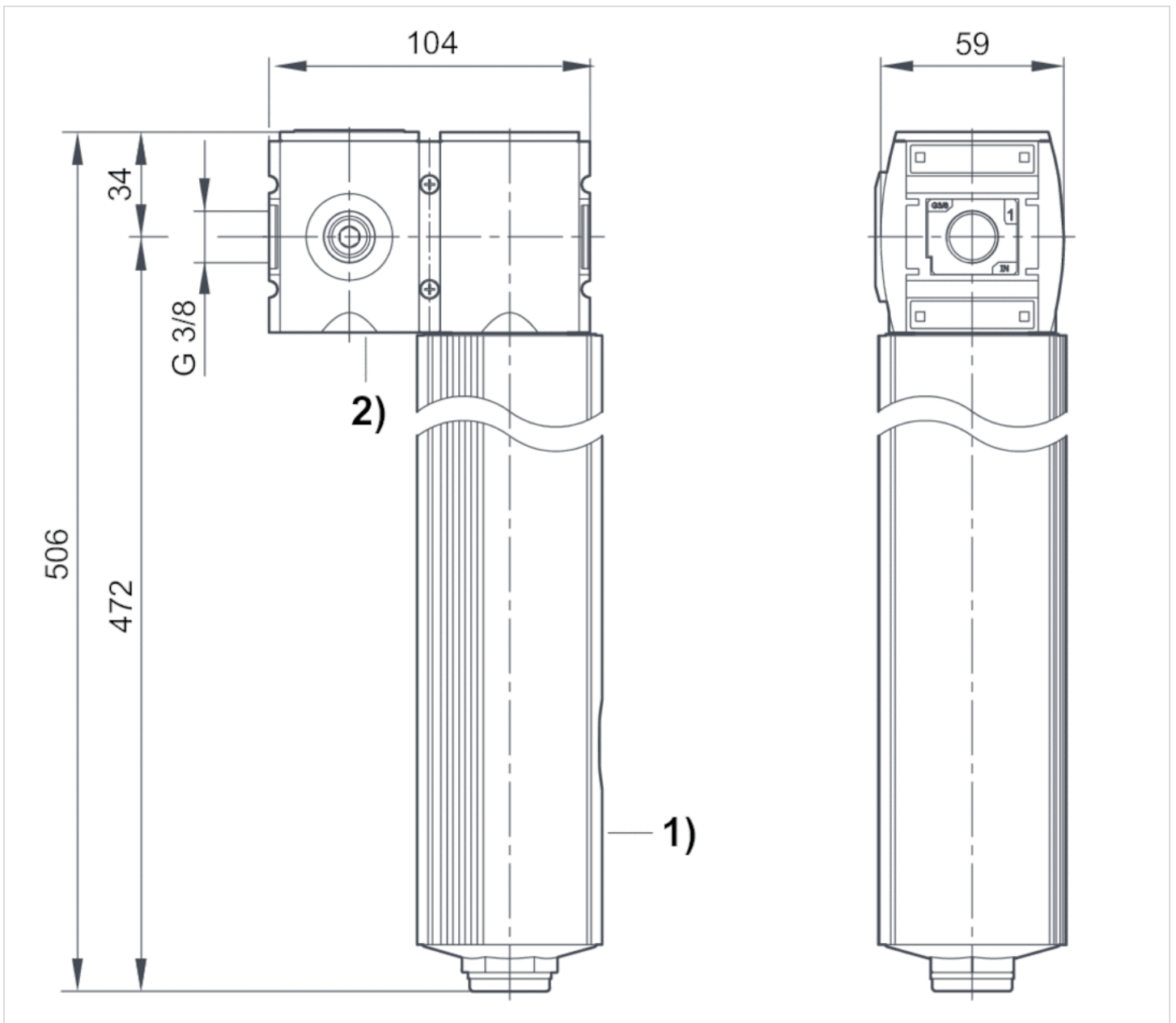

- 1) Diaphragm-type dryer
- 2) Incl. second distributor

Diagrams

performance charts

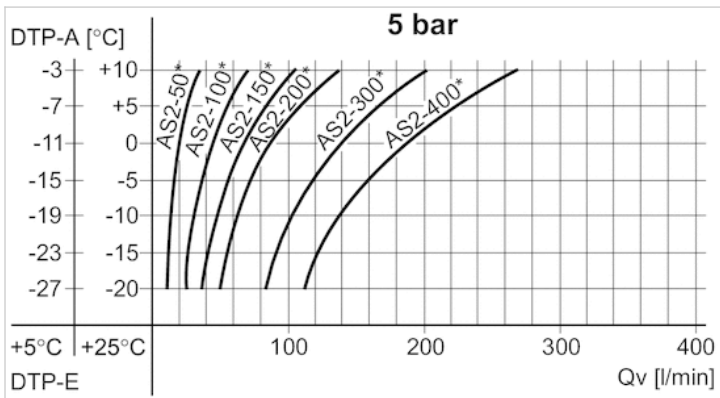

DTP-E: pressure dew point input
 DTP-A: pressure dew point output
 Qv: input flow rate (nominal flow rate Qn + purge air)
 * Nominal flow Qn

performance charts

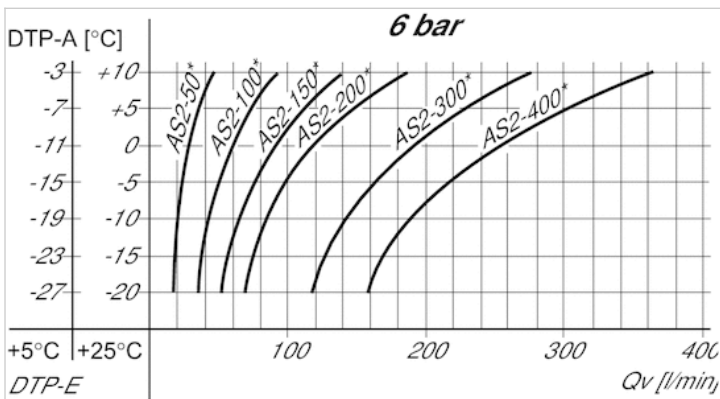

DTP-E: pressure dew point input
 DTP-A: pressure dew point output
 Qv: input flow rate (nominal flow rate Qn + purge air)
 * Nominal flow Qn

performance charts

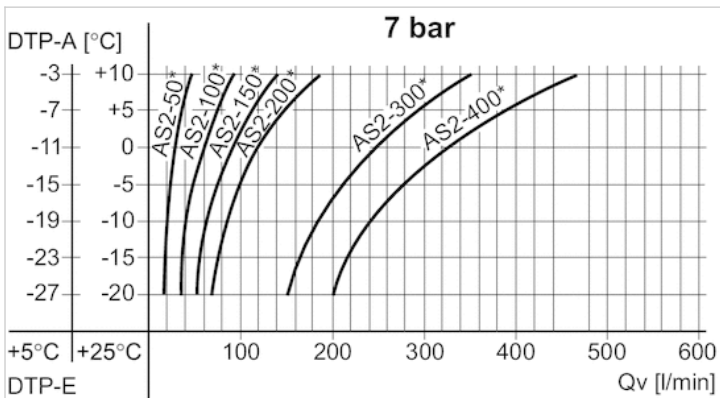

DTP-E: pressure dew point input
 DTP-A: pressure dew point output

Qv: input flow rate (nominal flow rate Qn + purge air)
 * Nominal flow Qn

performance charts

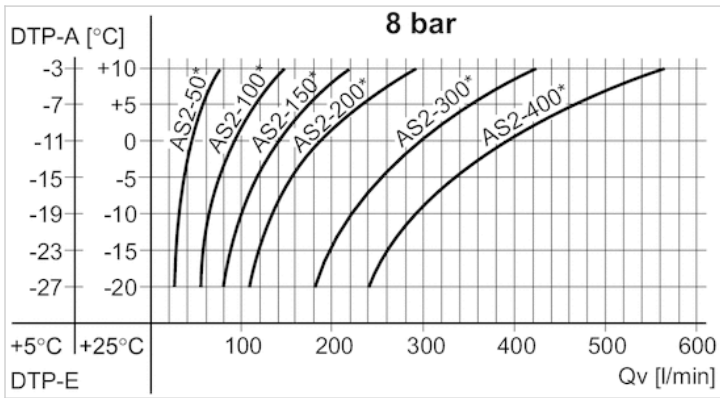

DTP-E: pressure dew point input
 DTP-A: pressure dew point output
 Qv: input flow rate (nominal flow rate Qn + purge air)
 * Nominal flow Qn

Example wanted:

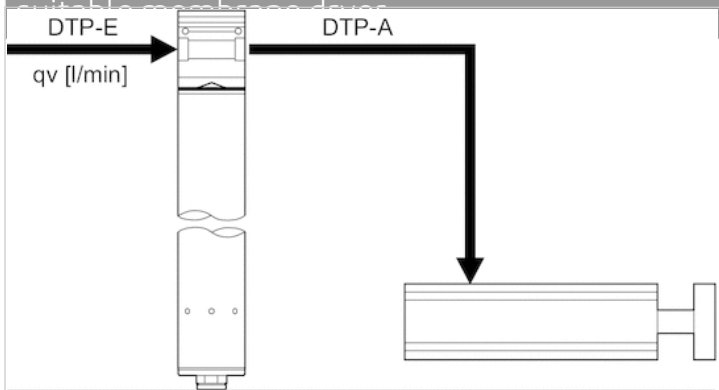

Example give values: Qn = 80 l/min, DTP-E = +5 (+25)°C

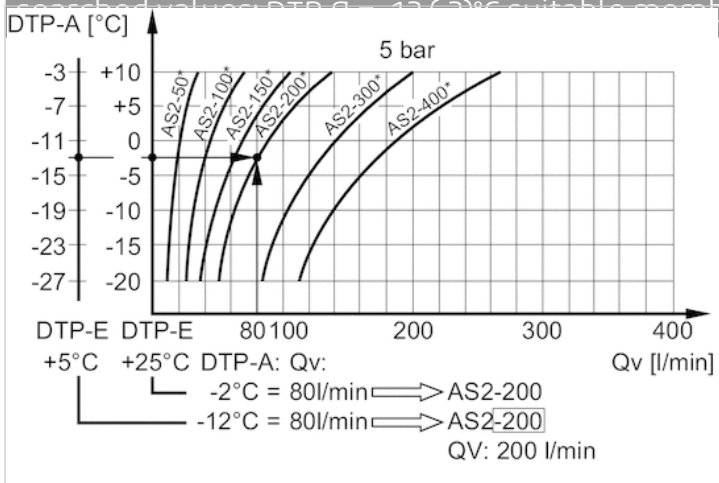

Result: membrane dryer series AS2-200
 (with a Qn of 200 l/min), part no. R412006081

* Nominal flow Qn

Accessories overview

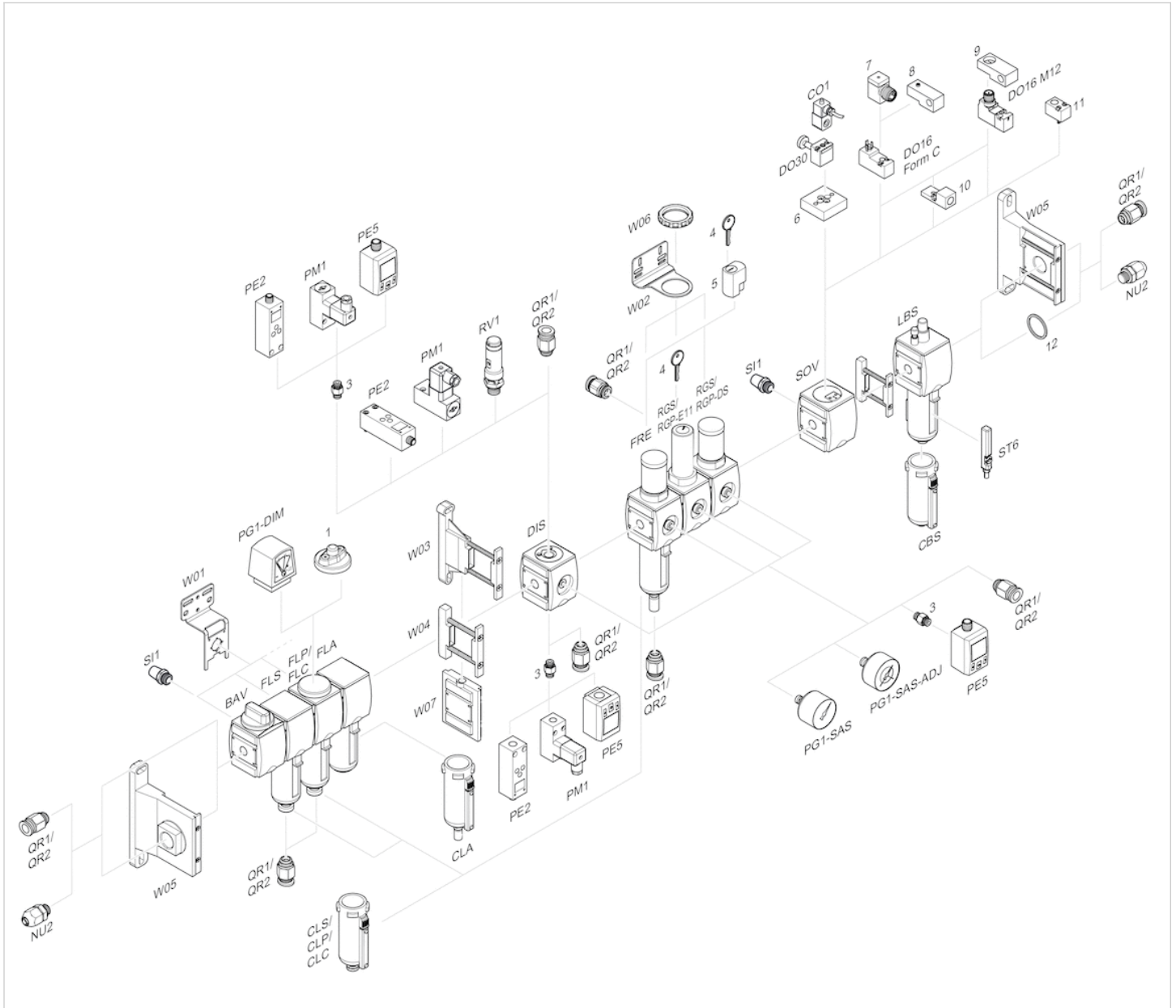

- 1 = contamination display
- 3 = Double nipple
- 4 = Key for E11 locking
- 5 = mortise lock
- 6 = Transition plate DO30
- 7 = Adapter, Series CON-VP
- 8 = Mounting aid DO16, form C
- 9 = Mounting aid DO16, M12
- 10 = Adapter for external pilot air
- 11 = Adapter pneumatic operation
- 12 = Sealing ring

Standard oil-mist lubricator, Series AS2-LBS

- G 1/4 G 3/8

- suitable for ATEX

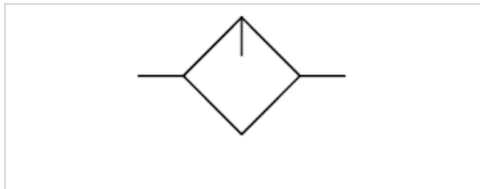

Version	Oil-mist lubricator, Can be assembled into blocks
Parts	Standard oil-mist lubricator
Mounting orientation	vertical
Certificates	suitable for ATEX
Working pressure min./max.	0.5 ... 16 bar
Ambient temperature min./max.	-10 ... 50 °C
Medium temperature min./max.	-10 ... 50 °C
Medium	Compressed air Neutral gases
Lubricator reservoir volume	40 cm ³
Type of filling	Semi-automatic oil filling during operation Manual oil filling
Weight	0.229 kg

Technical data

Part No.	Port	Nominal flow Qn	Material Reservoir	Protective guard
R412006225	G 1/4	2800 l/min	Polycarbonate	Polyamide
R412006226	G 1/4	2800 l/min	Polycarbonate	Polyamide
R412006229	G 1/4	2800 l/min	Die cast zinc with window	-
R412006231	G 3/8	3100 l/min	Polycarbonate	Polyamide
R412006232	G 3/8	3100 l/min	Polycarbonate	Polyamide
R412006235	G 3/8	3100 l/min	Die cast zinc with window	-

Part No.	Reservoir	Fig.	
R412006225	reservoir, PA, with PA protective guard	Fig. 1	1)
R412006226	reservoir, PA, with PA protective guard	Fig. 2	2)
R412006229	reservoir, metal, standard, with inspection glass	Fig. 3	1)
R412006231	reservoir, PA, with PA protective guard	Fig. 4	1)
R412006232	reservoir, PA, with PA protective guard	Fig. 5	2)
R412006235	reservoir, metal, standard, with inspection glass	Fig. 6	1)

Nominal flow Qn with secondary pressure p2 = 6 bar at Δp = 1 bar

1) Suitable for use in Ex zones 1, 2, 21, 22.

2) Electrical level detection, Suitable for use in Ex zones 1, 2, 21, 22.

Technical information

The pressure dew point must be at least 15 °C under ambient and medium temperature and may not exceed 3 °C .
 Electrical level detection only with ST6 sensor with reed contact, sensor holder included in the scope of the delivery.
 Sensor not included in scope of delivery, sensor installation prepared.

The entire preset drip quantity enters the pressure system.

Manual oil filling possible during operation at a maximum operating pressure of 10 bar.

Suitable for use in Ex zones 1, 2, 21, 22.

Note: Polycarbonate reservoirs are susceptible to solvents, supplementary information can be found at "Customer information".

A change in the flow direction (from air supply on the left to air supply on the right) occurs by rotating installation by 180° about the vertical axis. Please see the operating instructions for further details.

Oil dosing at 1000 l/min 1-2 drops

Technical information

Material	
Housing	Polyamide
Front plate	Acrylonitrile butadiene styrene
Seals	Acrylonitrile butadiene rubber
Threaded bushing	Die cast zinc
Reservoir	Polycarbonate Die cast zinc
Protective guard	Polyamide

Dimensions

Dimensions in mm, Fig. 1

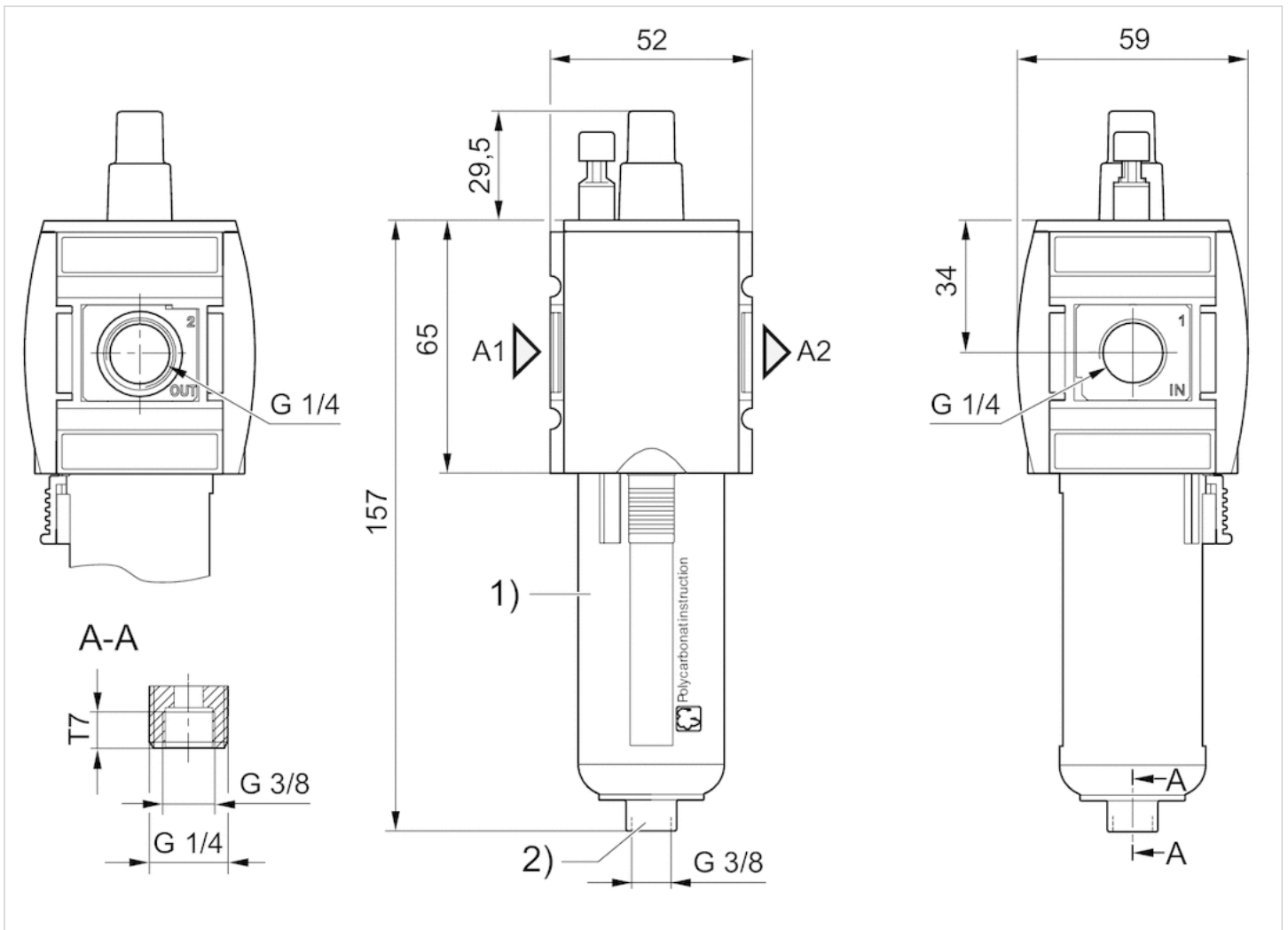

A1 = input

A2 = output

1) Plastic reservoir and protective guard with window

2) Port for semi-automatic oil filling

Dimensions in mm, Fig. 2

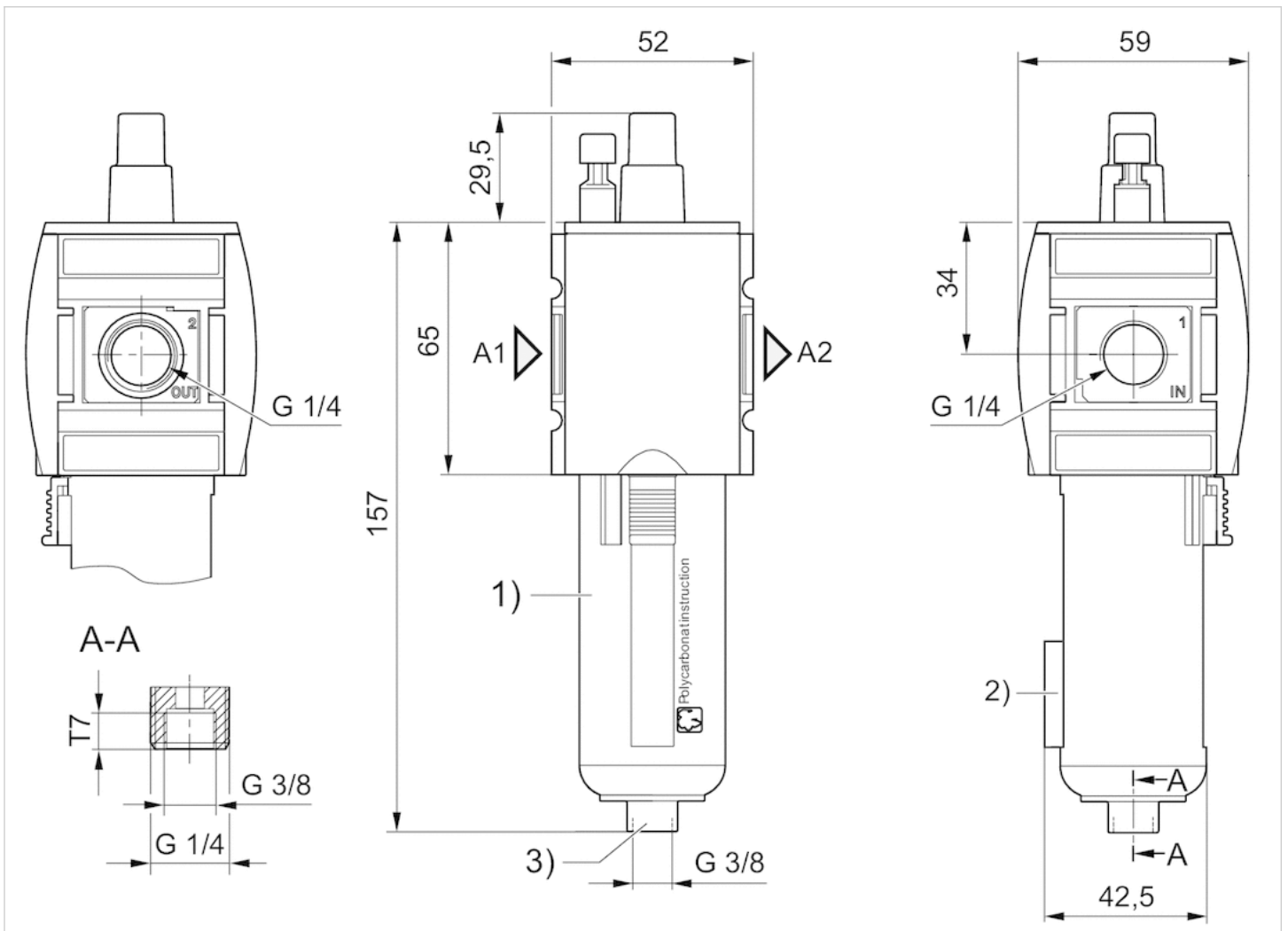

- A1 = input
- A2 = output
- 1) Plastic reservoir and protective guard with window
- 2) Holder for sensor
- 3) Port for semi-automatic oil filling

Dimensions in mm, Fig. 3

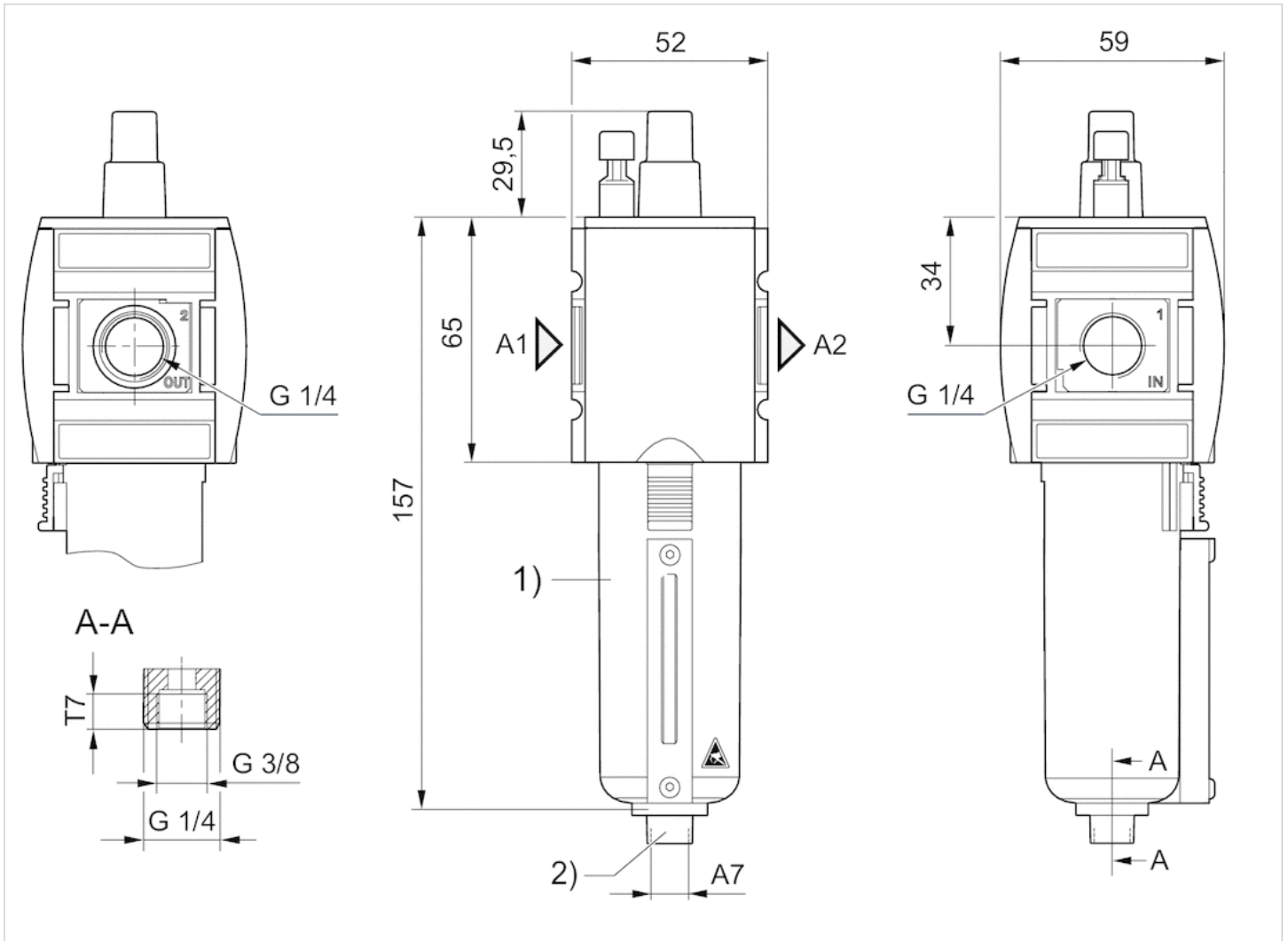

- A1 = input
- A2 = output
- 1) Metal reservoir with inspection glass
- 2) Port for semi-automatic oil filling

Dimensions in mm, Fig. 4

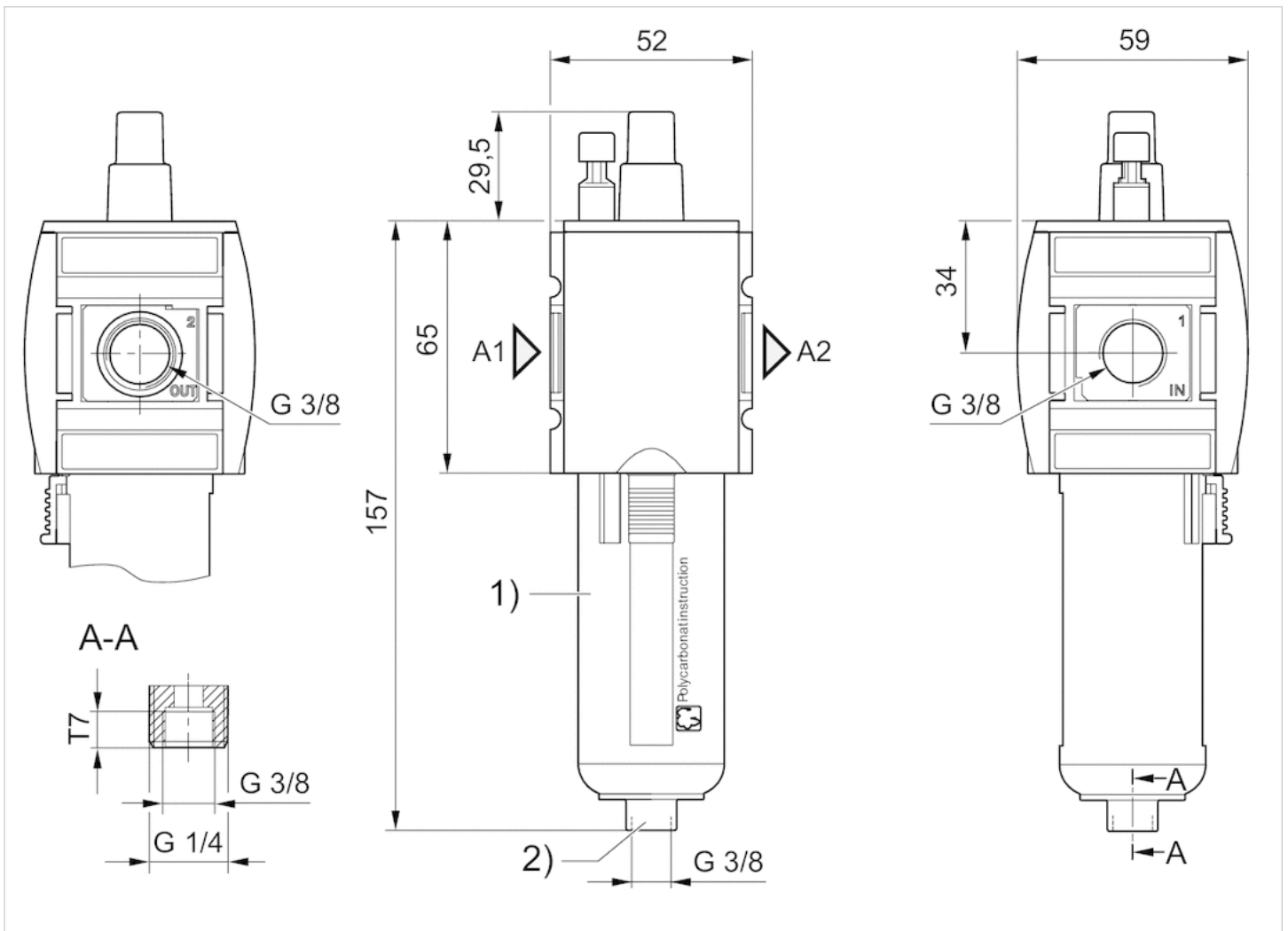

- A1 = input
- A2 = output
- 1) Plastic reservoir and protective guard with window
- 2) Port for semi-automatic oil filling

Dimensions in mm, Fig. 5

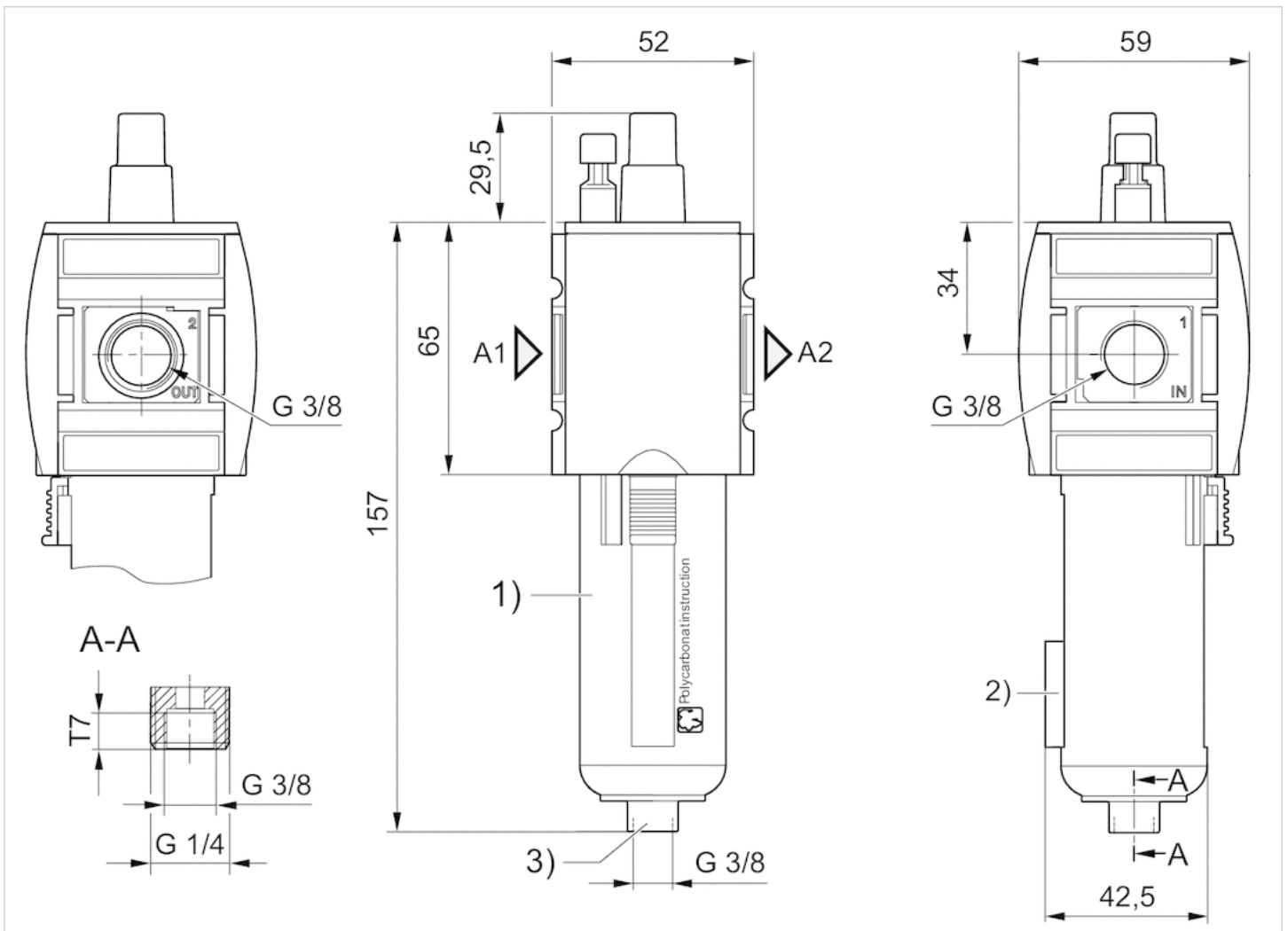

- A1 = input
- A2 = output
- 1) Plastic reservoir and protective guard with window
- 2) Holder for sensor
- 3) Port for semi-automatic oil filling

Dimensions in mm, Fig. 6

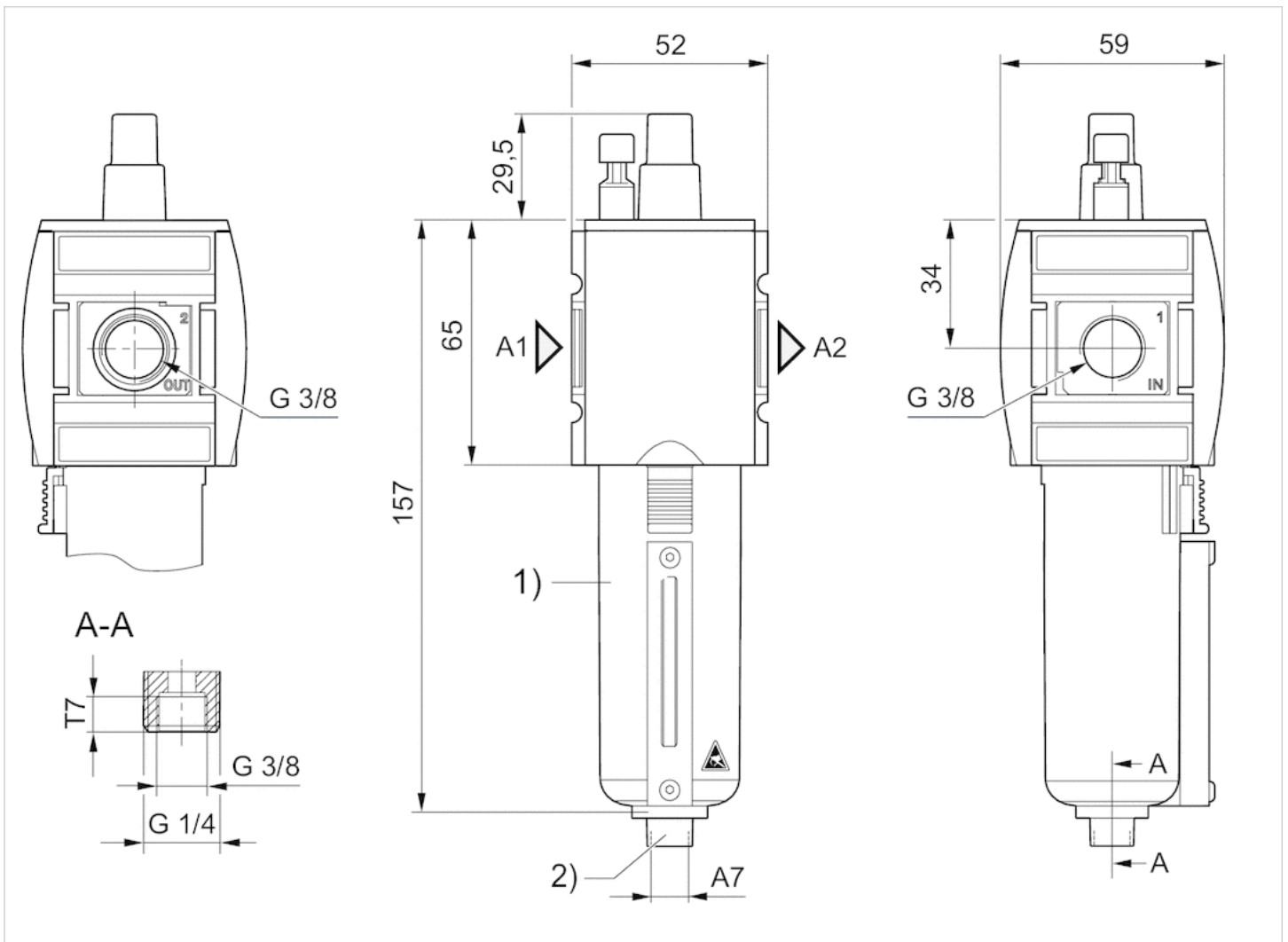

- A1 = input
- A2 = output
- 1) Metal reservoir with inspection glass
- 2) Port for semi-automatic oil filling

Diagrams

Lubricator activation margin

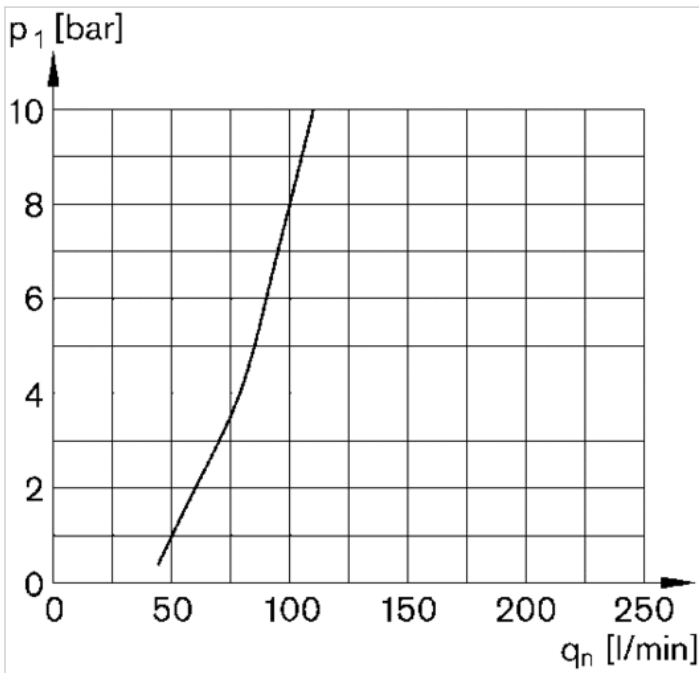

p_1 = working pressure
 q_n = nominal flow

Flow rate characteristic

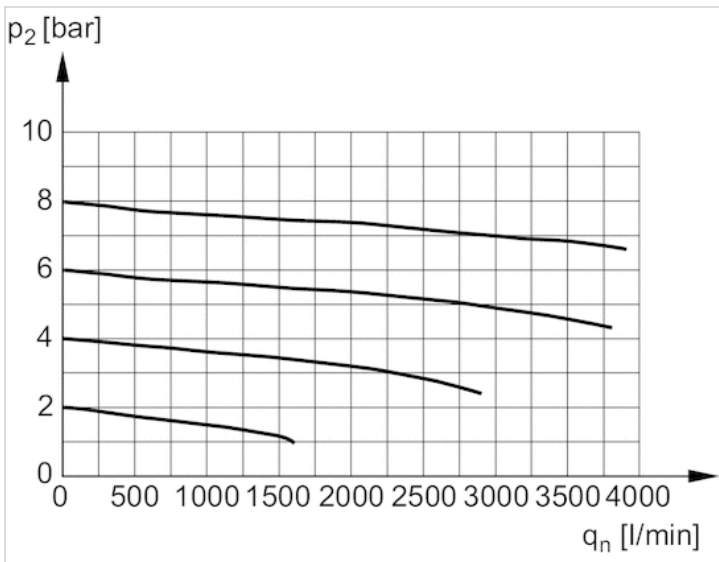

p_2 = secondary pressure
 q_n = nominal flow

Accessories overview

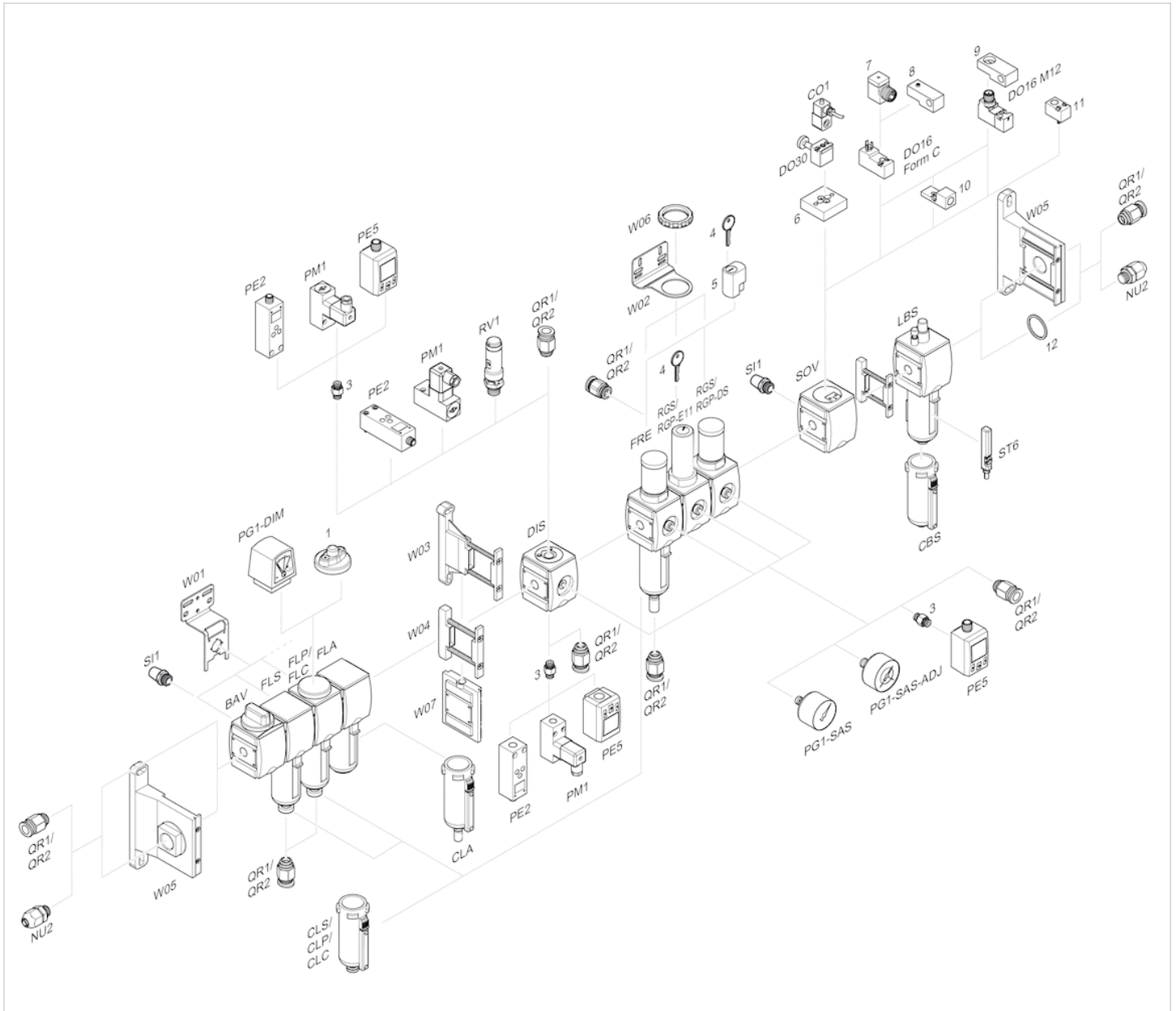

- 1 = contamination display
- 3 = Double nipple
- 4 = Key for E11 locking
- 5 = mortise lock
- 6 = Transition plate DO30
- 7 = Adapter, Series CON-VP
- 8 = Mounting aid DO16, form C
- 9 = Mounting aid DO16, M12
- 10 = Adapter for external pilot air
- 11 = Adapter pneumatic operation
- 12 = Sealing ring















Filling unit, electrically operated, Series AS2-SSU

- adjustable filling time
- Compressed air connection G 1/4 G 3/8
- Pipe connection
- suitable for ATEX
- ATEX optional



Version	Poppet valve, Can be assembled into blocks
Parts	Filling valve, 3/2-directional valve, electrically operated
Nominal flow	1300 l/min
Nominal flow 1 ▶ 2	1300 l/min
Nominal flow 2 ▶ 3	380 l/min
Working pressure min./max.	2.5 ... 10 bar
Medium	Compressed air Neutral gases
Medium temperature min./max.	-10 ... 50 °C
Ambient temperature min./max.	-10 ... 50 °C
Pilot	Internal
Sealing principle	Soft sealing
Max. particle size	25 µm
Protection class acc. to DIN EN 61140 with plug	IP65
Duty cycle	100 %
Weight	0.424 kg

Technical data

Part No.			Compressed air connection input	Compressed air connection output	Exhaust
R412006277		—	G 1/4	G 1/4	G 1/4
R412006286		—	G 1/4	G 1/4	G 1/4
R412006282		—	G 3/8	G 3/8	G 1/4
R412006278			G 1/4	G 1/4	G 1/4
R412006279			G 1/4	G 1/4	G 1/4
R412006280			G 1/4	G 1/4	G 1/4
R412006283			G 3/8	G 3/8	G 1/4
R412006285			G 3/8	G 3/8	G 1/4
R412006383			G 1/4	G 1/4	G 1/4

Part No.	Operational voltage	Operational voltage	Operational voltage
	DC	AC 50 Hz	AC 60 Hz
R412006277	-	-	-
R412006286	-	-	-
R412006282	-	-	-
R412006278	24 V	-	-
R412006279	-	110 V	110 V
R412006280	-	220 V	230 V
R412006283	24 V	-	-
R412006285	-	220 V	230 V
R412006383	24 V	-	-

Part No.	Power consumption	Holding power	Holding power	Switch-on power
	DC	AC 50 Hz	AC 60 Hz	AC 50 Hz
R412006277	-	-	-	-
R412006286	-	-	-	-
R412006282	-	-	-	-
R412006278	2 W	-	-	-
R412006279	-	1.6 VA	1.4 VA	2.2 VA
R412006280	-	1.6 VA	1.4 VA	2.2 VA
R412006283	2 W	-	-	-
R412006285	-	1.6 VA	1.4 VA	2.2 VA
R412006383	2 W	-	-	-

Part No.	Switch-on power	Electrical connection	Connector standard
	AC 60 Hz	Pilot valve	
R412006277	-	-	-
R412006286	-	-	-
R412006282	-	-	-
R412006278	-	Plug, ISO 15217, form C	ISO 15217
R412006279	1.6 VA	Plug, ISO 15217, form C	ISO 15217
R412006280	1.6 VA	Plug, ISO 15217, form C	ISO 15217
R412006283	-	Plug, ISO 15217, form C	ISO 15217
R412006285	1.6 VA	Plug, ISO 15217, form C	ISO 15217
R412006383	-	Plug, M12x1	-

Part No.	basic valve with electrical connector
R412006277	Basic valve without pilot valve
R412006286	Basic valve without pilot valve, with CNOMO subbase
R412006282	Basic valve without pilot valve
R412006278	Basic valve with pilot valve
R412006279	Basic valve with pilot valve
R412006280	Basic valve with pilot valve
R412006283	Basic valve with pilot valve
R412006285	Basic valve with pilot valve
R412006383	Basic valve with pilot valve

Part No.	Reverse polarity protection	Fig.	
R412006277	-	Fig. 1	1)
R412006286	-	Fig. 3	1)
R412006282	-	Fig. 2	1)
R412006278	Protected against polarity reversal	Fig. 4	2)
R412006279	Protected against polarity reversal	Fig. 4	2)
R412006280	Protected against polarity reversal	Fig. 4	2)
R412006283	Protected against polarity reversal	Fig. 5	2)
R412006285	Protected against polarity reversal	Fig. 5	2)
R412006383	-	Fig. 6	3)

Nominal flow Q_n with secondary pressure $p_2 = 6$ bar at $\Delta p = 1$ bar

- 1) Suitable for use in Ex zones 1, 2, 21, 22.
- 2) IP65
- 3) With adjustment screw lock, IP65

Technical information

The pressure dew point must be at least 15 °C under ambient and medium temperature and may not exceed 3 °C .

A change in the flow direction (from air supply on the left to air supply on the right) occurs by rotating installation by 180° about the vertical axis. Please see the operating instructions for further details.

ATEX optional: The ATEX ID depends on the selected pilot valve.

Do not position filling valves or filling units upstream of open consumers, such as nozzles, air barriers, air curtains, since these may prevent through connection of components.

The filling valve builds up pressure slowly in the pneumatic systems, i.e. prevents a sudden pressure build-up during a recommissioning after a mains pressure failure or avoids emergency OFF switching. This allows dangerous abrupt cylinder motions to be avoided.

Technical information

Material	
Housing	Polyamide
Front plate	Acrylonitrile butadiene styrene
Seals	Acrylonitrile butadiene rubber
Threaded bushing	Die cast zinc

Dimensions

Dimensions in mm, Fig. 1

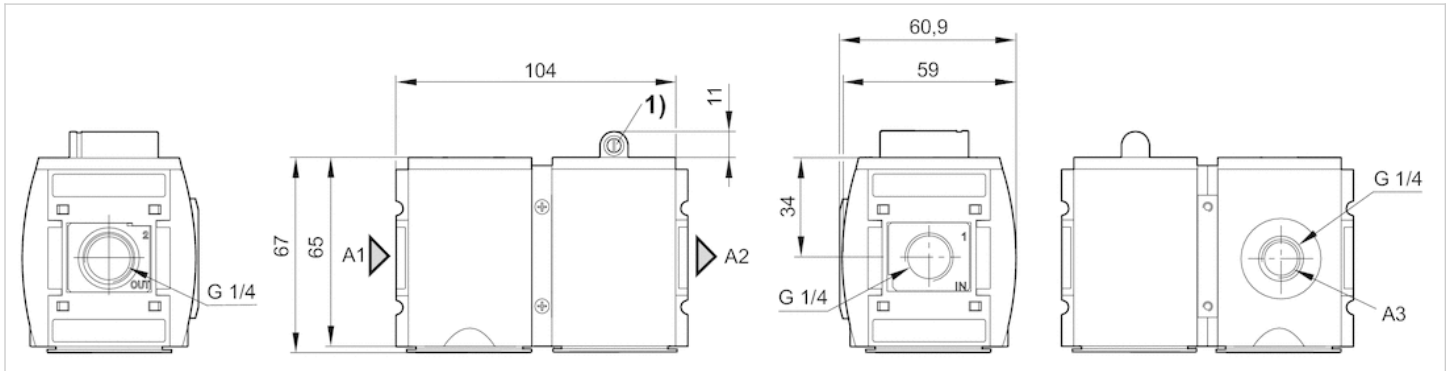

- A1 = input
- A2 = output
- A3 = ventilation port
- 1) Adjustment screw for filling time

Dimensions in mm, Fig. 2

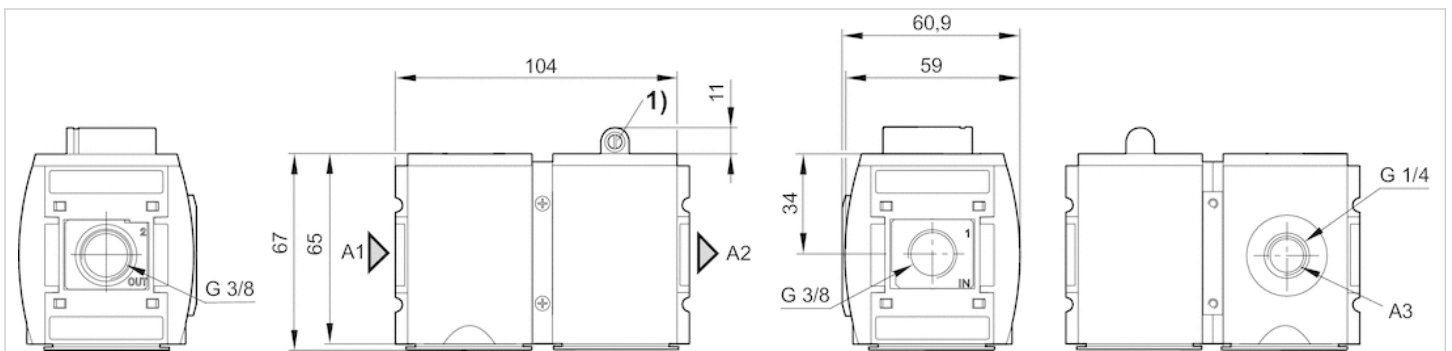

- A1 = input
- A2 = output
- A3 = ventilation port
- 1) Adjustment screw for filling time

Dimensions in mm, Fig. 3

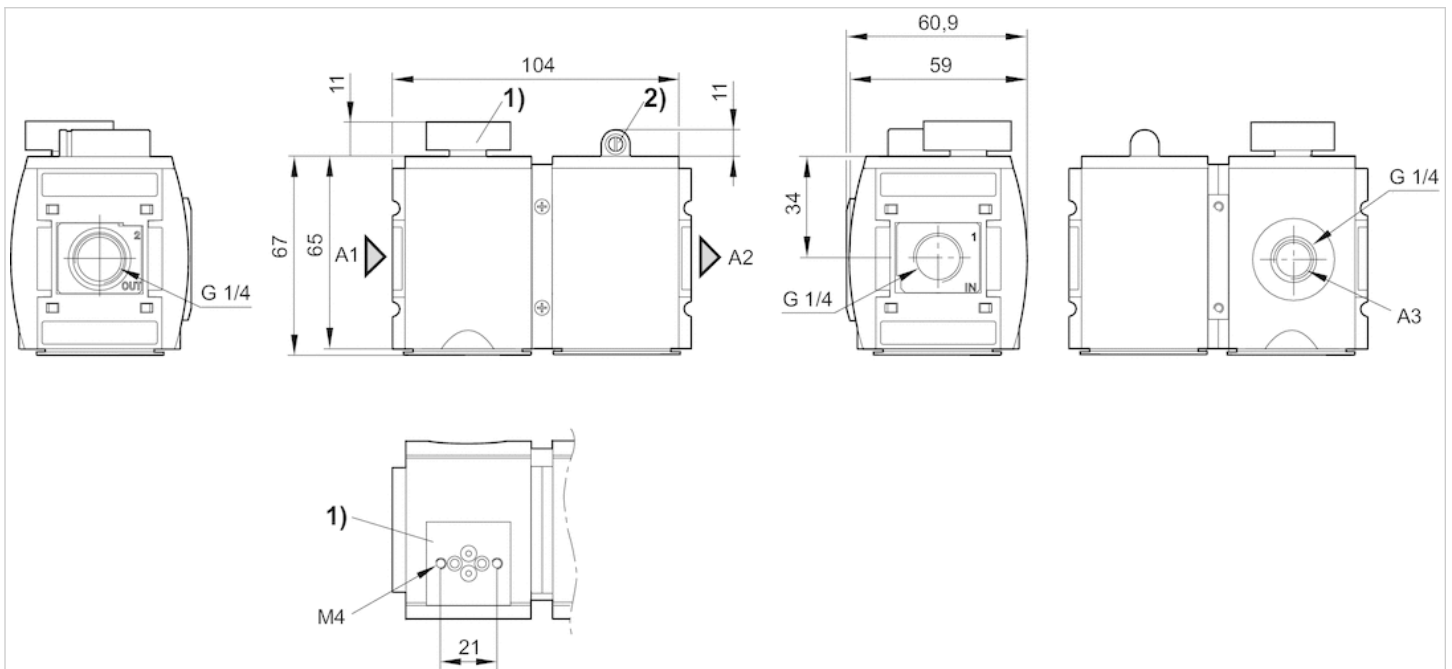

- A1 = input
- A2 = output
- A3 = ventilation port
- 1) Transition plate with CNOMO porting configuration for pilot valve DO30
- 2) Adjustment screw for filling time

Dimensions in mm, Fig. 4

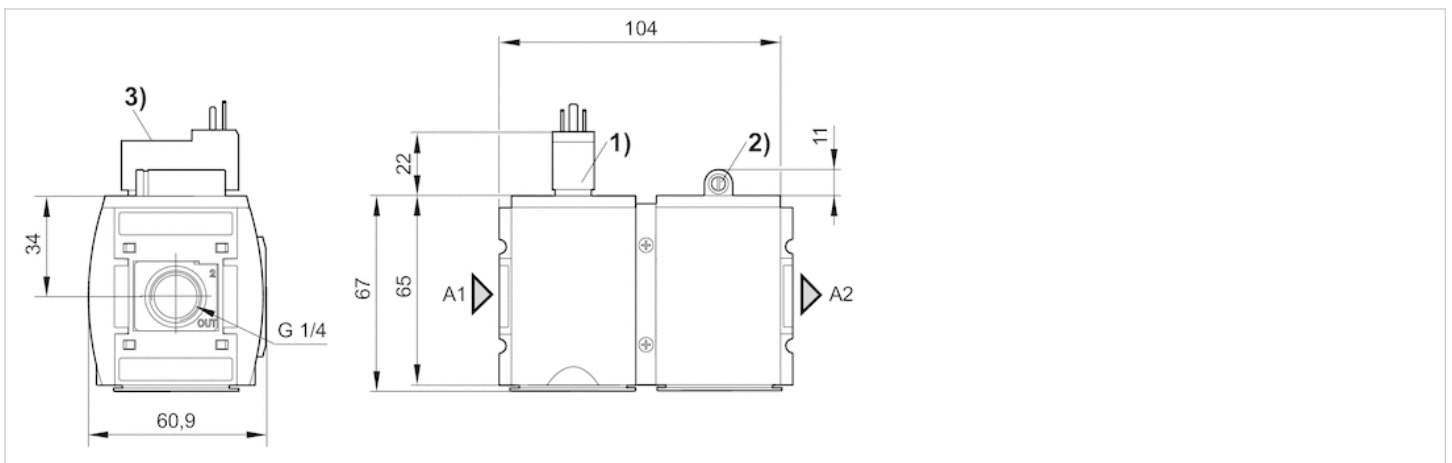

- A1 = input
- A2 = output
- 1) Connection for valve plug connector according to ISO 15217 (form C)
- 2) Adjustment screw for filling time
- 3) Manual override

Dimensions in mm, Fig. 5

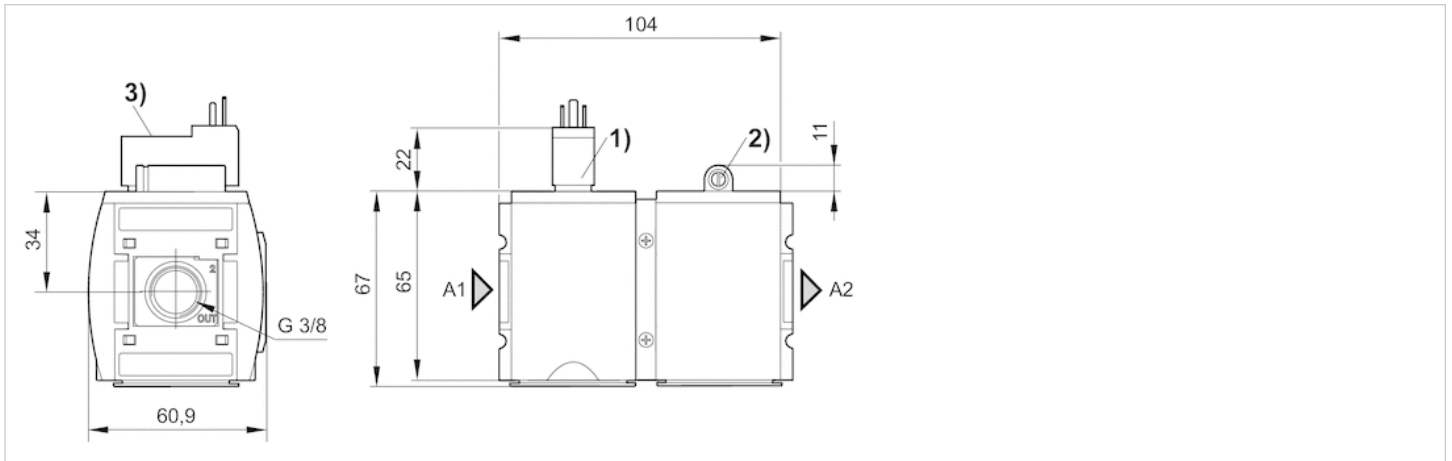

- A1 = input
- A2 = output
- 1) Connection for valve plug connector according to ISO 15217 (form C)
- 2) Adjustment screw for filling time
- 3) Manual override

Dimensions in mm, Fig. 6

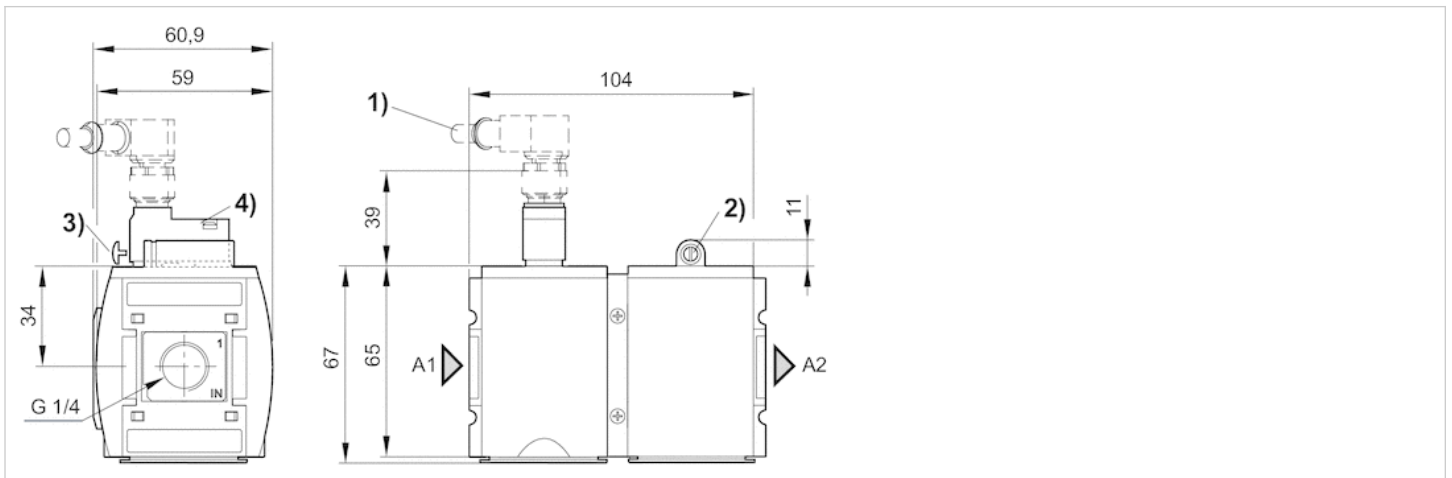

- A1 = input
- A2 = output
- 1) Port for plug M12x1
- 2) Adjustment screw for filling time
- 3) Adjustment screw lock
- 4) Manual override

Diagrams

secondary pressure while filling

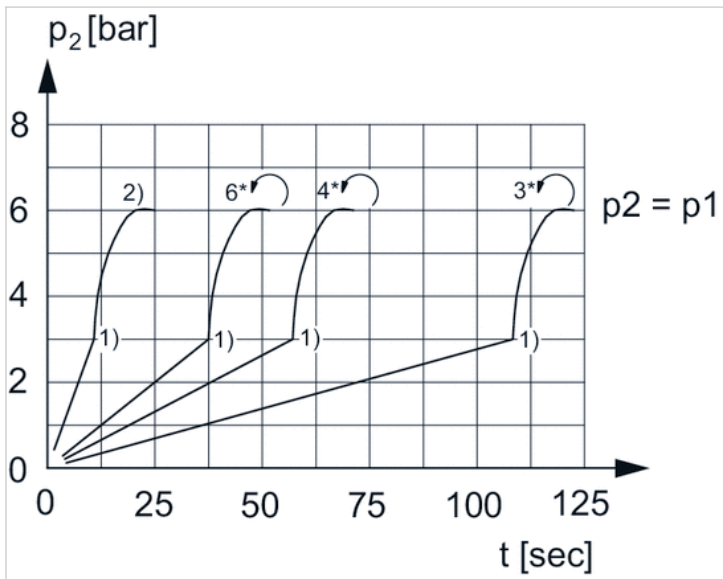

p1 = working pressure

p2 = secondary pressure

t = filling time, adjustable via adjustment screw (throttle)

1) Switching point: adjustable filling time, fixed change-over pressure $\approx 0.5 \times p1$ (50%)

2) Throttle fully opened

* Adjustment screw rotations

Flow rate characteristic

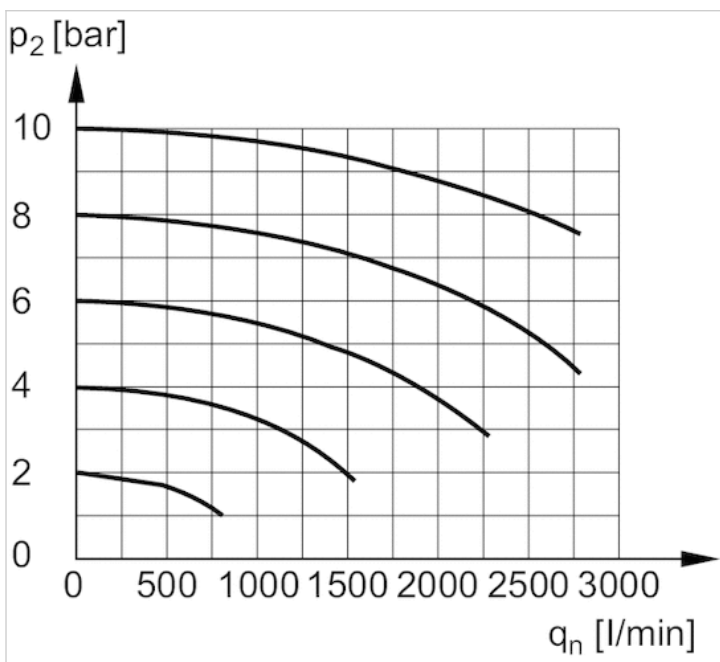

p2 = secondary pressure

qn = nominal flow

Pin assignments

Pin assignment M12x1

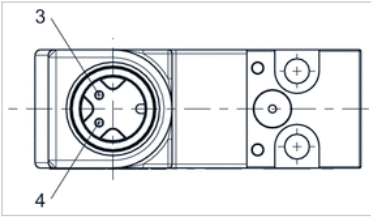

- 3: +/-
- 4: +/-

Accessories overview

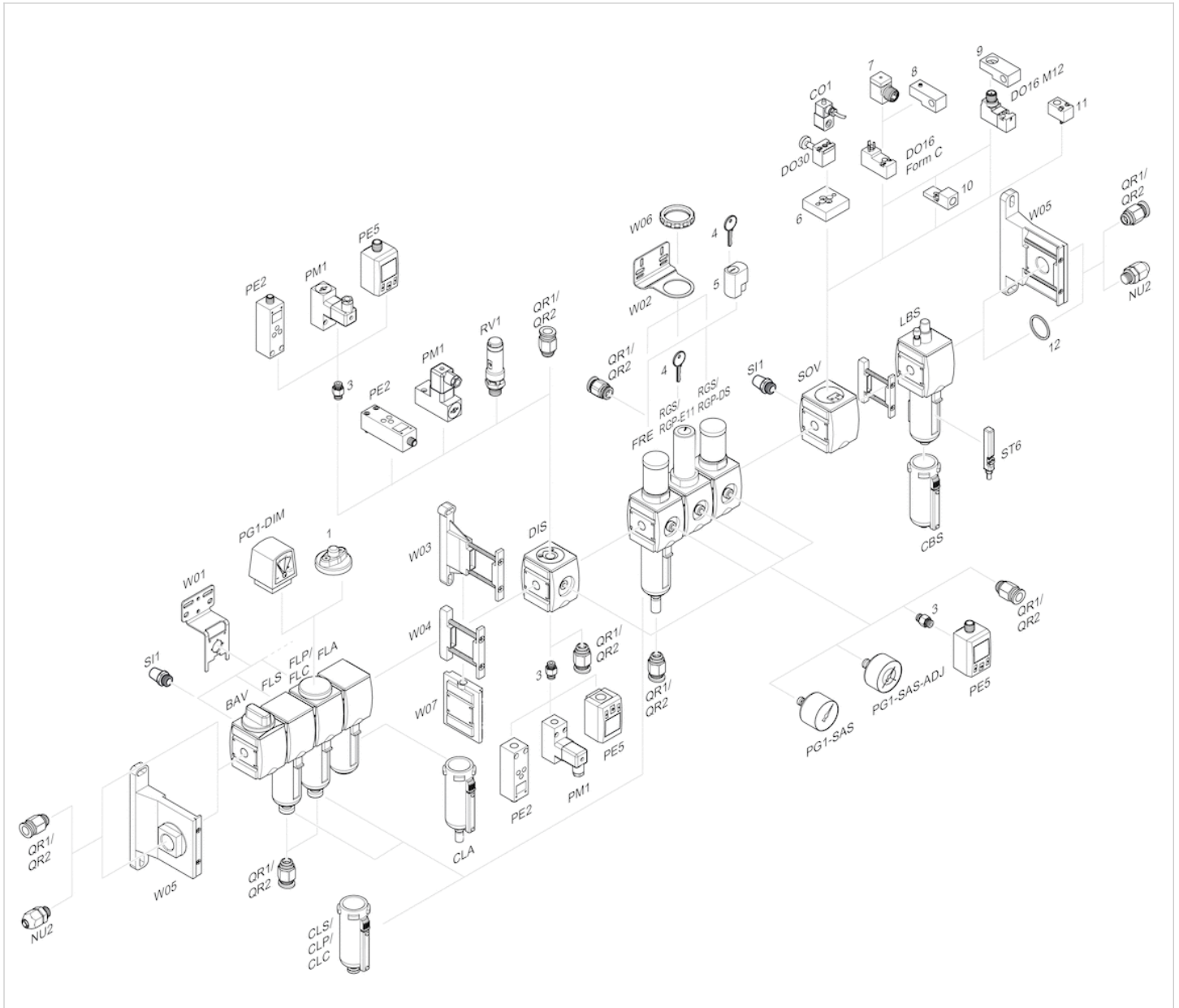

1 = contamination display

- 3 = Double nipple
- 4 = Key for E11 locking
- 5 = mortise lock
- 6 = Transition plate DO30
- 7 = Adapter, Series CON-VP
- 8 = Mounting aid DO16, form C
- 9 = Mounting aid DO16, M12
- 10 = Adapter for external pilot air
- 11 = Adapter pneumatic operation
- 12 = Sealing ring

Filling unit, electrically operated, Series AS2-SSU

- With electrical priority circuit, adjustable filling time.
- Compressed air connection G 1/4
- Pipe connection
- Electrical connection: Plug, M12x1

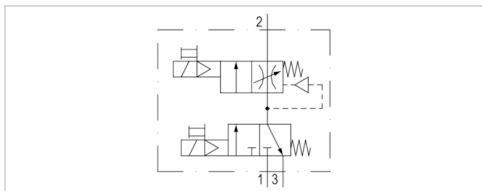

Version	Poppet valve, Can be assembled into blocks
Parts	Filling valve, 3/2-directional valve, electrically operated
Nominal flow	2000 l/min
Nominal flow 1 ▶ 2	2000 l/min
Nominal flow 2 ▶ 3	380 l/min
Working pressure min./max.	2.5 ... 10 bar
Medium	Compressed air Neutral gases
Medium temperature min./max.	-10 ... 50 °C
Ambient temperature min./max.	-10 ... 50 °C
Pilot	Internal
Sealing principle	Soft sealing
Max. particle size	25 µm
Protection class acc. to DIN EN 61140 with plug	IP65
Duty cycle	100 %
Weight	0.424 kg

Technical data

Part No.		Compressed air connection input	Compressed air connection output	Exhaust
R412006384		G 1/4	G 1/4	G 1/4

Part No.	Operational voltage	Power consumption	Electrical connection
		DC	Pilot valve
R412006384	DC 24 V	DC 2 W	Plug, M12x1

Part No.	basic valve with electrical connector
R412006384	Basic valve with pilot valve

Nominal flow Qn with secondary pressure p2 = 6 bar at Δp = 1 bar, With adjustment screw lock

Technical information

The pressure dew point must be at least 15 °C under ambient and medium temperature and may not exceed 3 °C .
A change in the flow direction (from air supply on the left to air supply on the right) occurs by rotating installation by 180° about the vertical axis. Please see the operating instructions for further details.

For unthrottled operation, the filling valve must be permanently electrically actuated.

Actuating the electric priority circuit disrupts the slow pressure build-up and pressure p1 is immediately applied.

The filling valve builds up pressure slowly in the pneumatic systems, i.e. prevents a sudden pressure build-up during a recommissioning after a mains pressure failure or avoids emergency OFF switching. This allows dangerous abrupt cylinder motions to be avoided.

Technical information

Material	
Housing	Polyamide
Front plate	Acrylonitrile butadiene styrene
Seals	Acrylonitrile butadiene rubber
Threaded bushing	Die cast zinc

Dimensions

Dimensions in mm

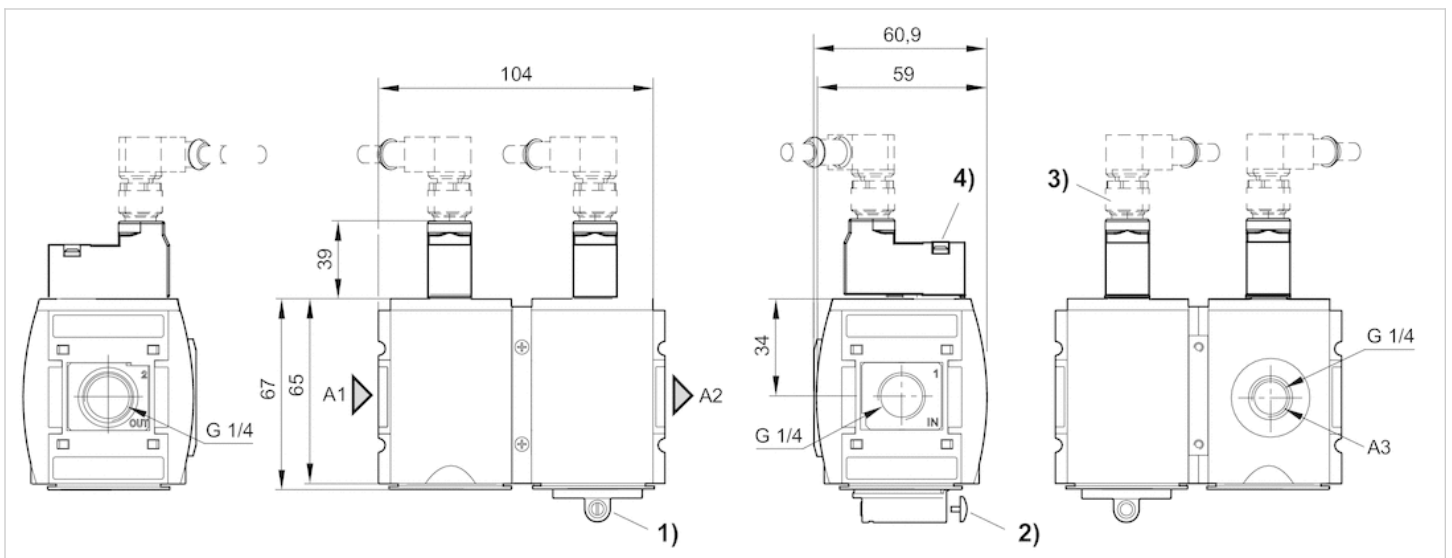

A1 = input

A2 = output

A3 = ventilation port

1) Adjustment screw for filling time

2) Adjustment screw lock

3) plug M12

4) Manual override

Diagrams

secondary pressure while filling

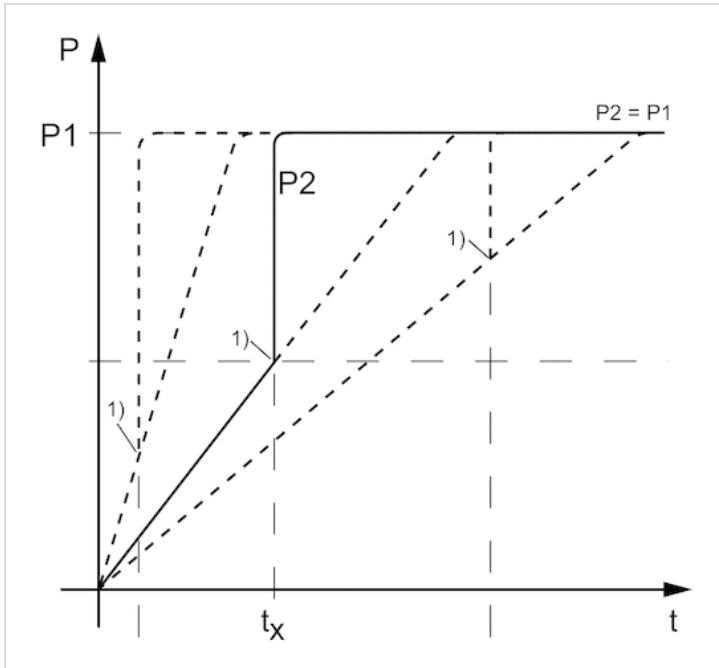

p_1 = working pressure
 p_2 = secondary pressure
 t = filling time
 t_x = switchover time
 1) Electrically triggered switching point
 Filling time adjustable via adjustment screw (throttle)

Flow rate characteristic

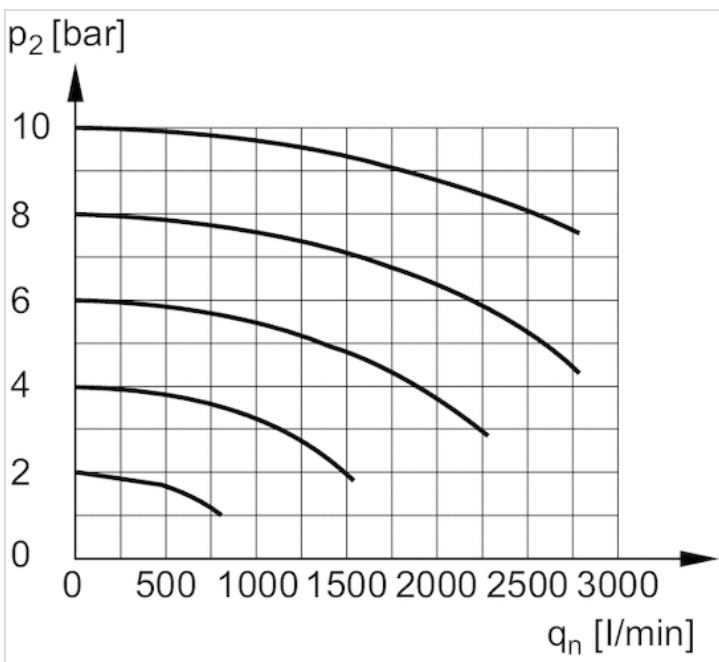

p_2 = secondary pressure
 q_n = nominal flow

Pin assignments

Pin assignment M12x1

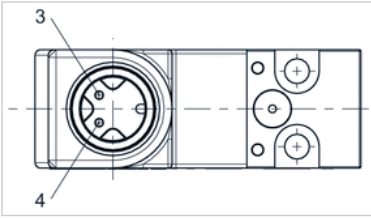

- 3: +/-
- 4: +/-

Accessories overview

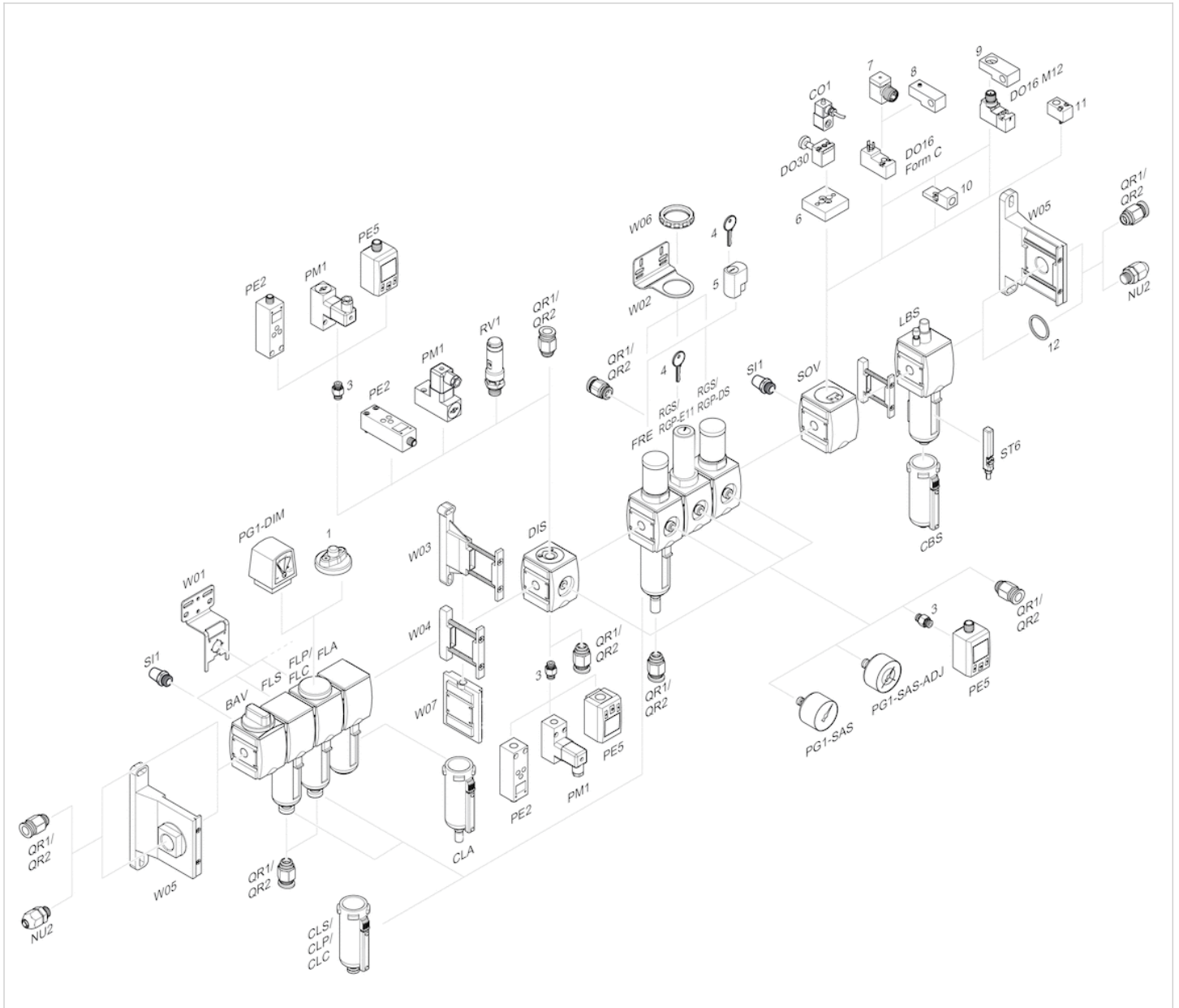

1 = contamination display

- 3 = Double nipple
- 4 = Key for E11 locking
- 5 = mortise lock
- 6 = Transition plate DO30
- 7 = Adapter, Series CON-VP
- 8 = Mounting aid DO16, form C
- 9 = Mounting aid DO16, M12
- 10 = Adapter for external pilot air
- 11 = Adapter pneumatic operation
- 12 = Sealing ring

Filling unit, pneumatically operated, Series AS2-SSU

- adjustable filling time
- Compressed air connection G 3/8 G 1/4
- Pipe connection
- suitable for ATEX

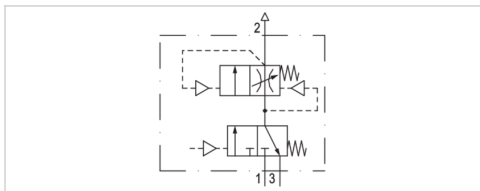

Version	Poppet valve, Can be assembled into blocks
Pilot	Internal
Sealing principle	Soft sealing
Certificates	suitable for ATEX
Working pressure min./max.	0 ... 16 bar
Control pressure min./max.	2.5 ... 16 bar
Ambient temperature min./max.	-10 ... 50 °C
Medium temperature min./max.	-10 ... 50 °C
Medium	Compressed air Neutral gases
Max. particle size	40 µm
Weight	0.424 kg

The delivered product varies from that in the illustration. See the drawing for an exact description.

Technical data

Part No.	Port	Pilot connection	Exhaust	Flow	Flow	Flow	Fig.	
				Qn	Qn 1►2	Qn 2►3		
R412006281	G 3/8	G 1/8	G 1/4	2000 l/min	2000 l/min	380 l/min	Fig. 1	1)
R412006276	G 1/4	G 1/8	G 1/4	2000 l/min	2000 l/min	380 l/min	Fig. 2	1)
R412006289	G 1/4	G 1/4	G 1/4	2000 l/min	2000 l/min	380 l/min	Fig. 2	2)

Nominal flow Qn with secondary pressure p2 = 6 bar at Δp = 1 bar

1) Suitable for use in Ex zones 1, 2, 21, 22.

2) With adjustment screw lock, Suitable for use in Ex zones 1, 2, 21, 22.

Technical information

The pressure dew point must be at least 15 °C under ambient and medium temperature and may not exceed 3 °C .

The filling valve builds up pressure slowly in the pneumatic systems, i.e. prevents a sudden pressure build-up during a recommissioning after a mains pressure failure or avoids emergency OFF switching. This allows dangerous abrupt cylinder motions to be avoided.

Technical information

Material	
Housing	Polyamide
Front plate	Acrylonitrile butadiene styrene
Seals	Acrylonitrile butadiene rubber
Threaded bushing	Die cast zinc

Dimensions

Dimensions in mm, Fig. 1

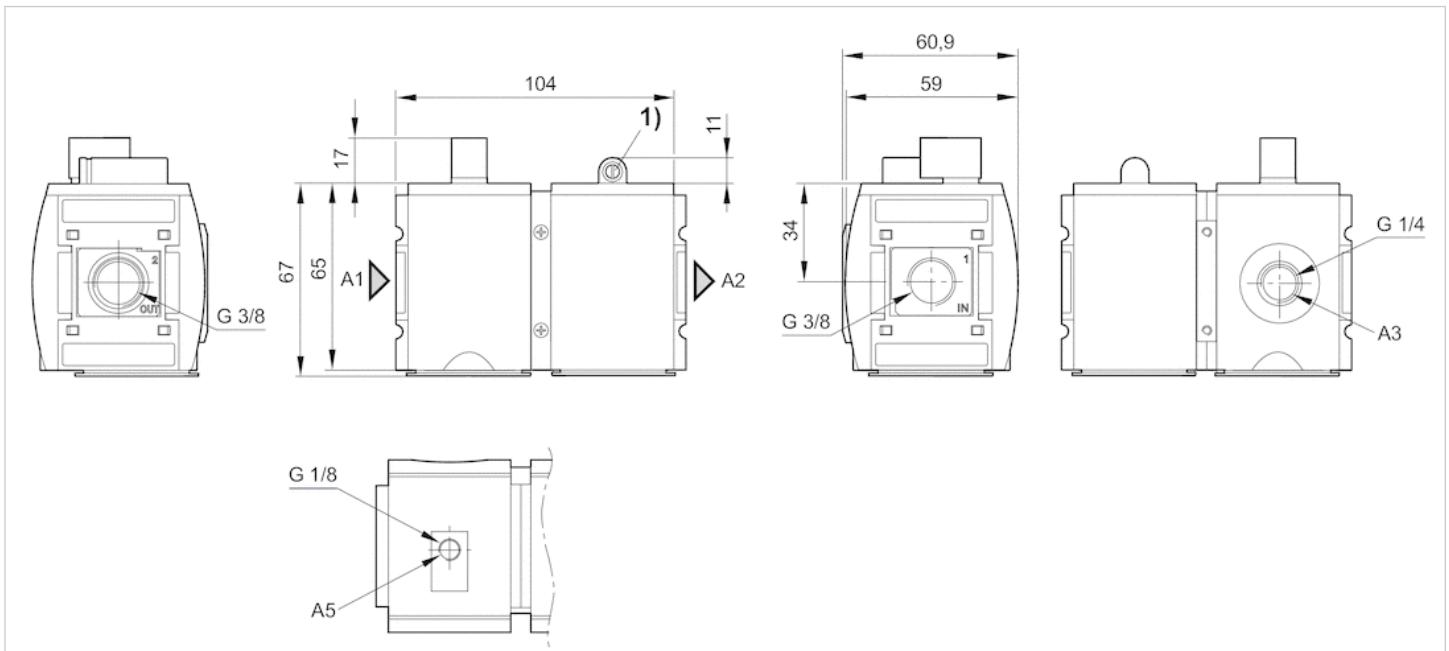

- A1 = input
- A2 = output
- A3 = ventilation port
- A5 = control pressure connection
- 1) Adjustment screw for filling time

Dimensions in mm, Fig. 2

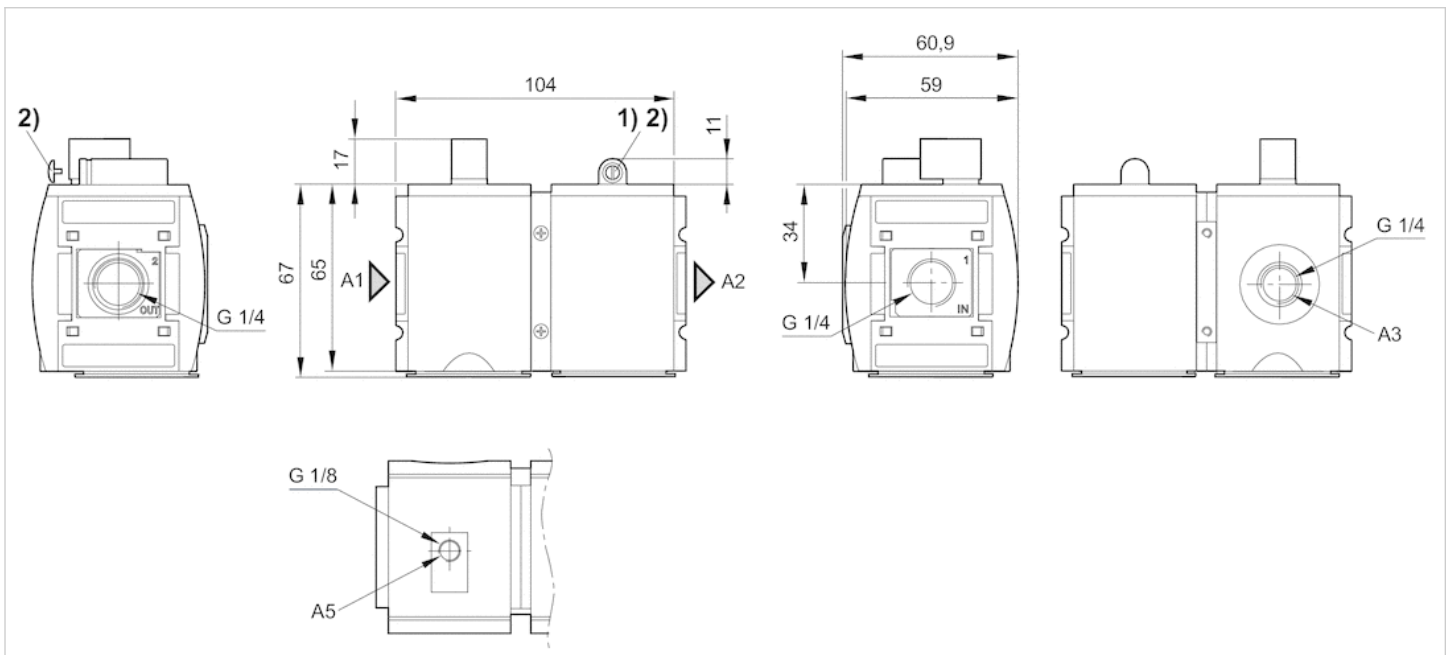

- A1 = input
- A2 = output
- A3 = ventilation port
- A5 = control pressure connection
- 1) Adjustment screw for filling time
- 2) Adjustment screw lock

Diagrams

Secondary pressure while filling

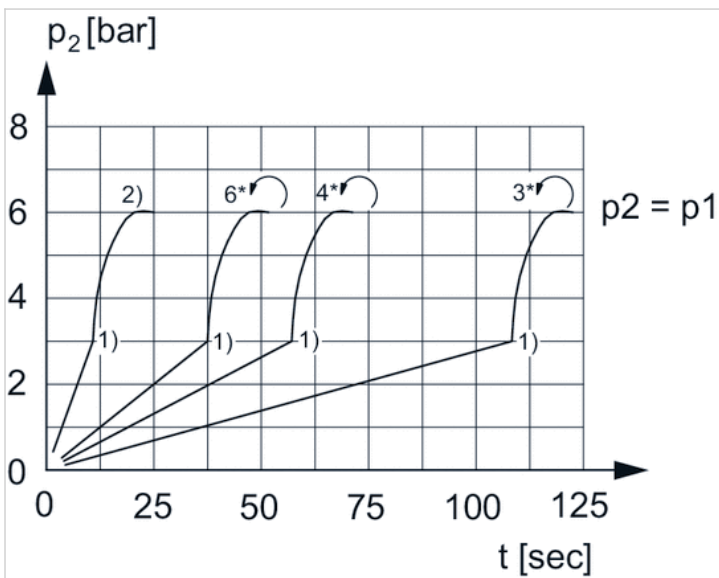

- p1 = working pressure
- p2 = secondary pressure
- t = filling time, adjustable via adjustment screw (throttle)
- 1) Switching point: adjustable filling time, fixed change-over pressure $\approx 0.5 \times p1$ (50%)
- 2) Throttle fully opened
- * Adjustment screw rotations

Flow rate characteristic

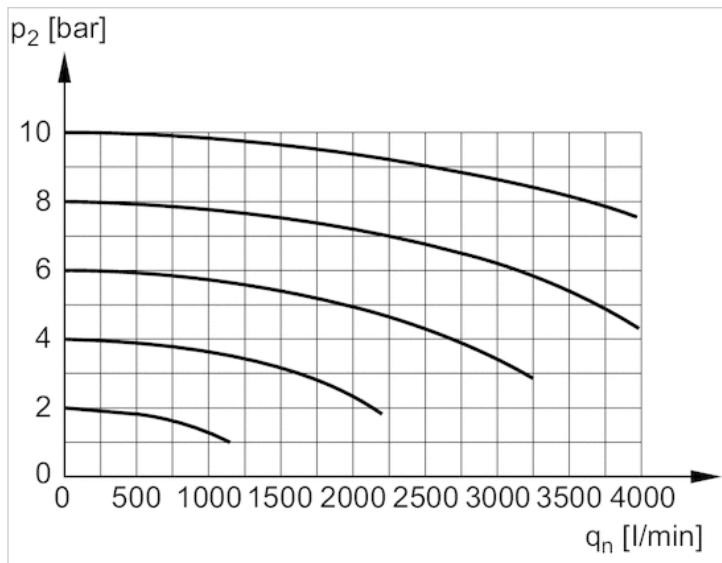

p_2 = secondary pressure

q_n = nominal flow

Accessories overview

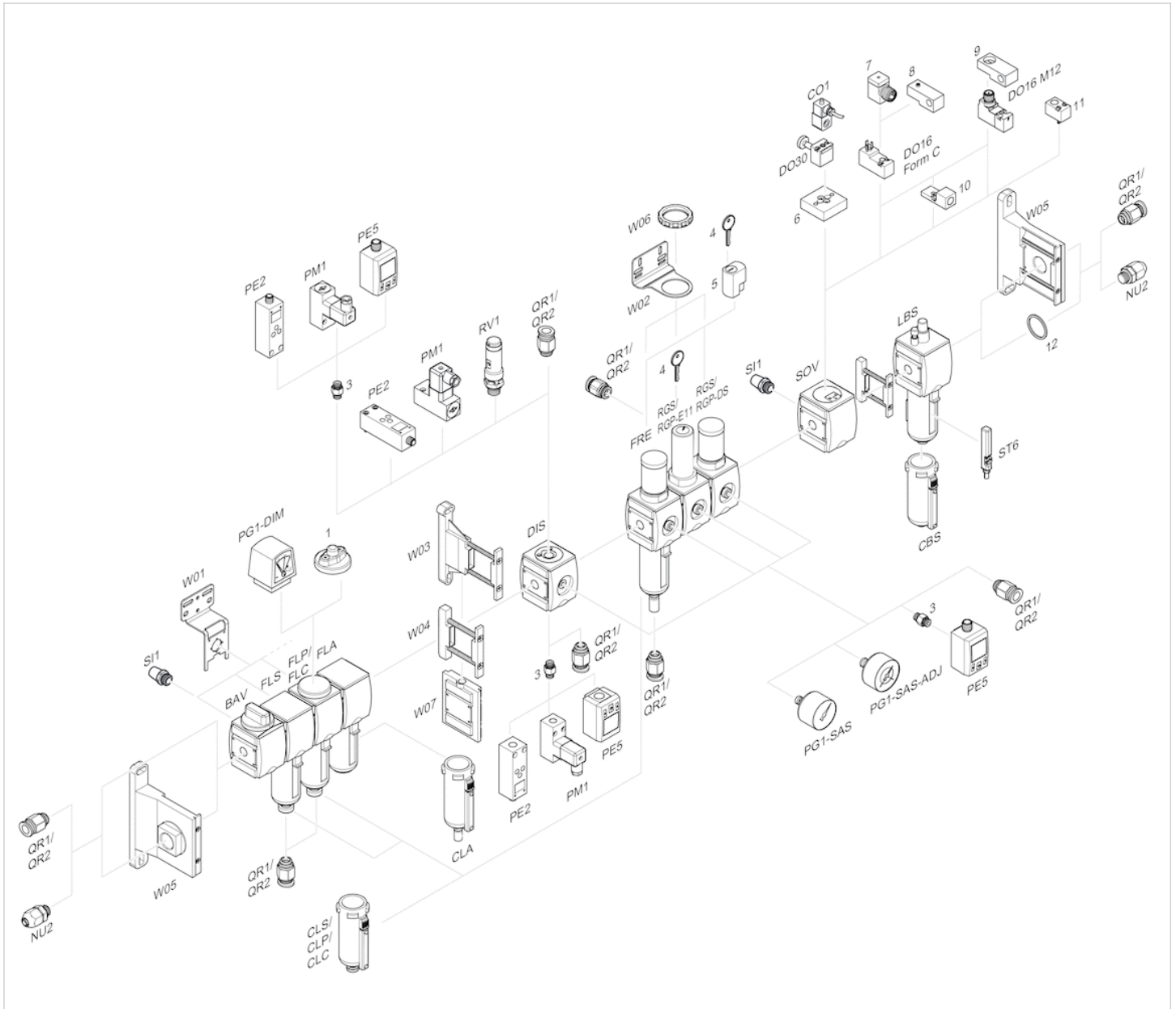

- 1 = contamination display
- 3 = Double nipple
- 4 = Key for E11 locking
- 5 = mortise lock
- 6 = Transition plate DO30
- 7 = Adapter, Series CON-VP
- 8 = Mounting aid DO16, form C
- 9 = Mounting aid DO16, M12
- 10 = Adapter for external pilot air
- 11 = Adapter pneumatic operation
- 12 = Sealing ring

Filling unit, pneumatically operated, Series AS2-SSU

- With electrical priority circuit, adjustable filling time.
- Compressed air connection G 1/4
- Pipe connection

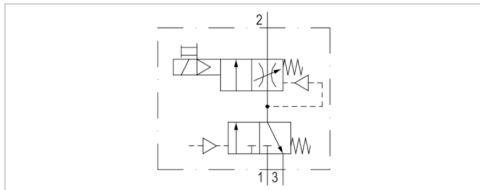

Version	Poppet valve, Can be assembled into blocks
Pilot	Internal
Sealing principle	Soft sealing
Working pressure min./max.	0 ... 16 bar
Control pressure min./max.	2.5 ... 16 bar
Ambient temperature min./max.	-10 ... 50 °C
Medium temperature min./max.	-10 ... 50 °C
Medium	Compressed air Neutral gases
Max. particle size	25 µm
Duty cycle	100 %
Protection class according to EN 60529:2000, without electrical connector	IP65
Weight	0.424 kg
	The delivered product varies from that in the illustration. See the drawing for an exact description.

Technical data

Part No.	Port	Pilot connection	Exhaust	Flow	Flow	Flow
				Qn	Qn 1→2	Qn 2→3
R412006382	G 1/4	G 1/8	G 1/4	2000 l/min	2000 l/min	380 l/min

Nominal flow Qn with secondary pressure p2 = 6 bar at Δp = 1 bar, Electr. connection: valve plug connector M12x1

Technical information

The pressure dew point must be at least 15 °C under ambient and medium temperature and may not exceed 3 °C .

The filling valve builds up pressure slowly in the pneumatic systems, i.e. prevents a sudden pressure build-up during a recommissioning after a mains pressure failure or avoids emergency OFF switching. This allows dangerous abrupt cylinder motions to be avoided.

Actuating the electric priority circuit disrupts the slow pressure build-up and pressure p1 is immediately applied.

For unthrottled operation, the filling valve must be permanently electrically actuated.

A change in the flow direction (from air supply on the left to air supply on the right) occurs by rotating installation by 180° about the vertical axis. Please see the operating instructions for further details.

Technical information

Material	
Housing	Polyamide
Front plate	Acrylonitrile butadiene styrene

Material	
Seals	Acrylonitrile butadiene rubber
Threaded bushing	Die cast zinc

Dimensions

Dimensions in mm

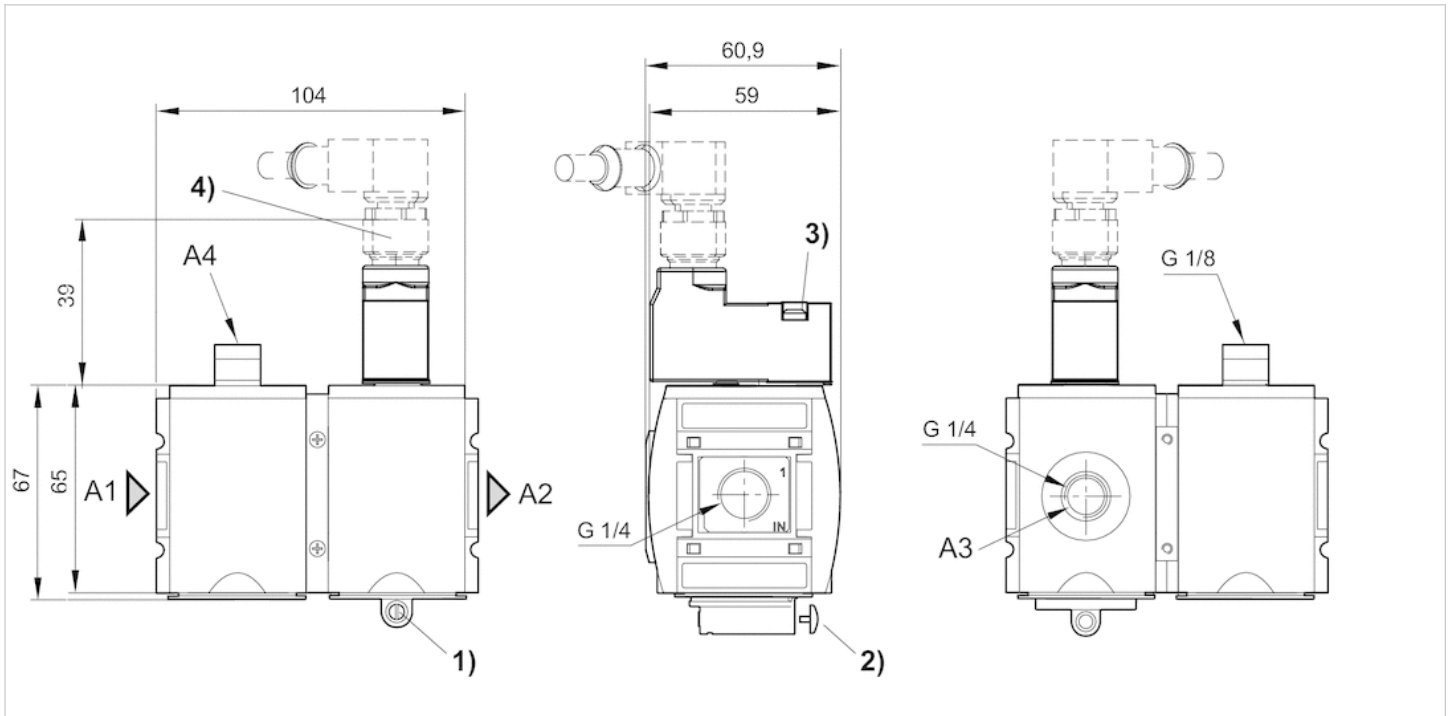

- A1 = input
- A2 = output
- A3 = ventilation port
- A4 = control pressure connection
- 1) Adjustment screw for filling time
- 2) Adjustment screw lock
- 3) plug M12
- 4) Manual override

Diagrams

secondary pressure while filling

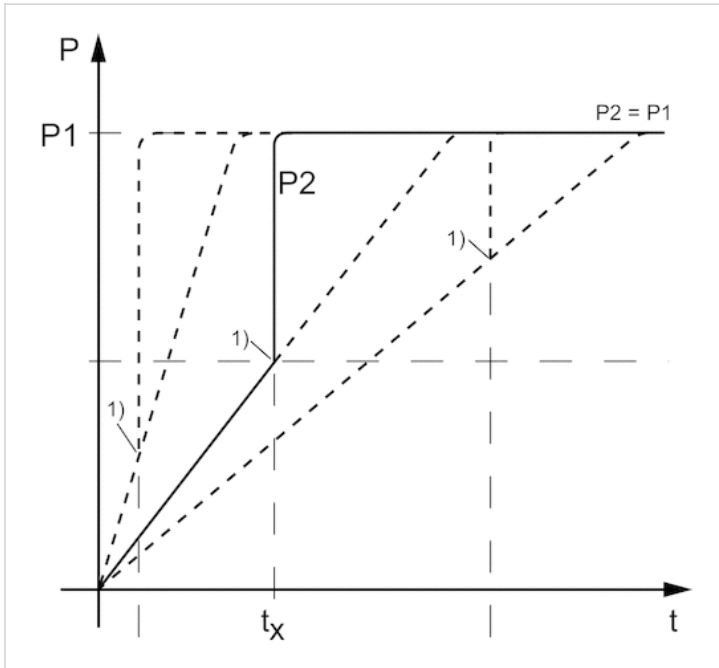

p1 = working pressure
 p2 = secondary pressure
 t = filling time
 tx = switchover time
 1) Electrically triggered switching point
 Filling time adjustable via adjustment screw (throttle)

Flow rate characteristic

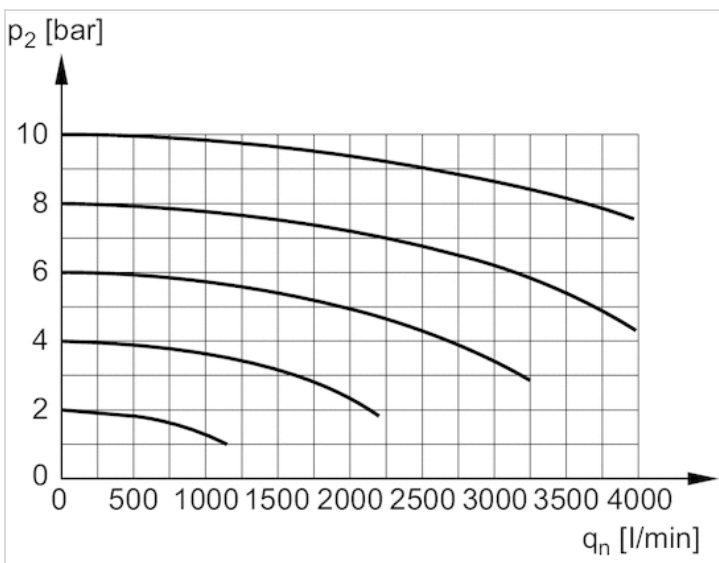

p2 = secondary pressure
 qn = nominal flow

Pin assignments

Pin assignment M12x1

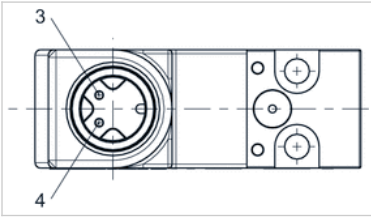

- 3: +/-
- 4: +/-

Accessories overview

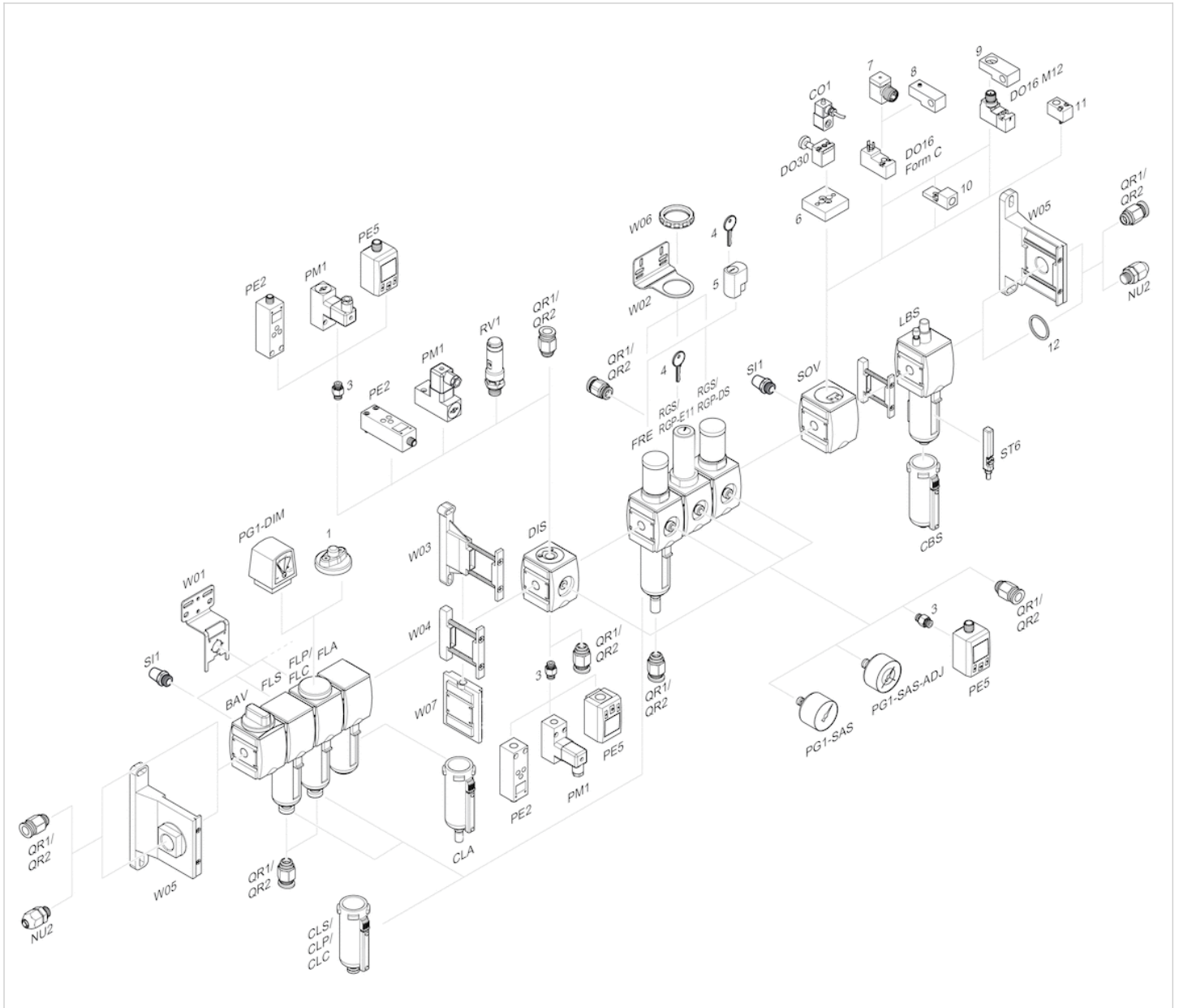

1 = contamination display

- 3 = Double nipple
- 4 = Key for E11 locking
- 5 = mortise lock
- 6 = Transition plate DO30
- 7 = Adapter, Series CON-VP
- 8 = Mounting aid DO16, form C
- 9 = Mounting aid DO16, M12
- 10 = Adapter for external pilot air
- 11 = Adapter pneumatic operation
- 12 = Sealing ring

Filling valve, Series AS2-SSV

- adjustable filling time
- Compressed air connection G 1/4 G 3/8
- suitable for ATEX



Version

Poppet valve, Can be assembled into blocks

Sealing principle

Soft sealing

Working pressure min./max.

2.5 ... 16 bar

Ambient temperature min./max.

-10 ... 50 °C

Medium temperature min./max.

-10 ... 50 °C

Medium

Compressed air Neutral gases

Max. particle size

40 µm

Weight

0.203 kg

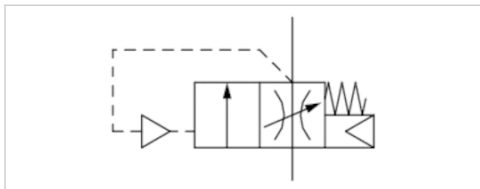

Technical data

Part No.	Port	Flow	Fig.	
		Qn		
R412006272	G 1/4	2000 l/min	Fig. 1	1)
R412006275	G 1/4	2000 l/min	Fig. 1	2)
R412006273	G 3/8	2000 l/min	Fig. 2	1)

Nominal flow Qn with secondary pressure p2 = 6 bar at $\Delta p = 1$ bar

1) Suitable for use in Ex zones 1, 2, 21, 22.

2) With adjustment screw lock, Suitable for use in Ex zones 1, 2, 21, 22.

Technical information

The pressure dew point must be at least 15 °C under ambient and medium temperature and may not exceed 3 °C .

A change in the flow direction (from air supply on the left to air supply on the right) occurs by rotating installation by 180° about the vertical axis. Please see the operating instructions for further details.

The filling valve builds up pressure slowly in the pneumatic systems, i.e. prevents a sudden pressure build-up during a recommissioning after a mains pressure failure or avoids emergency OFF switching. This allows dangerous abrupt cylinder motions to be avoided.

Do not position filling valves or filling units upstream of open consumers, such as nozzles, air barriers, air curtains, since these may prevent through connection of components.

Suitable for use in Ex zones 1, 2, 21, 22.

Technical information

Material	
Housing	Polyamide
Front plate	Acrylonitrile butadiene styrene
Seals	Acrylonitrile butadiene rubber
Threaded bushing	Die cast zinc

Dimensions

Dimensions in mm, Fig. 1

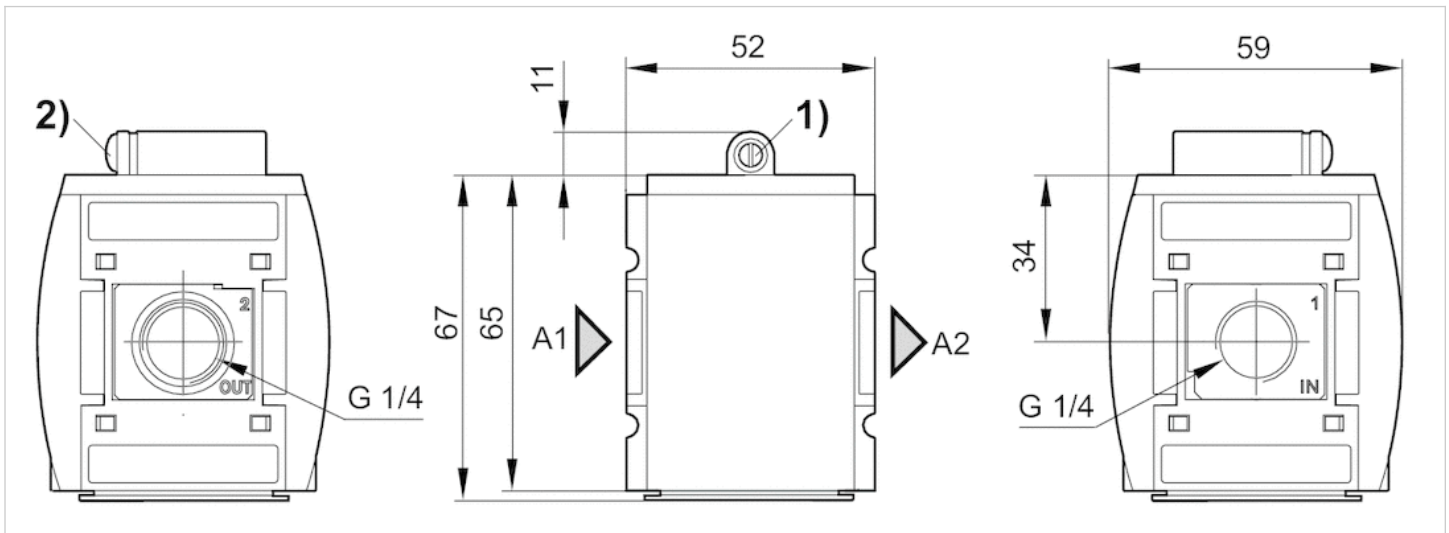

- A1 = input
- A2 = output
- 1) Adjustment screw for filling time
- 2) Adjustment screw lock

Dimensions in mm, Fig. 2

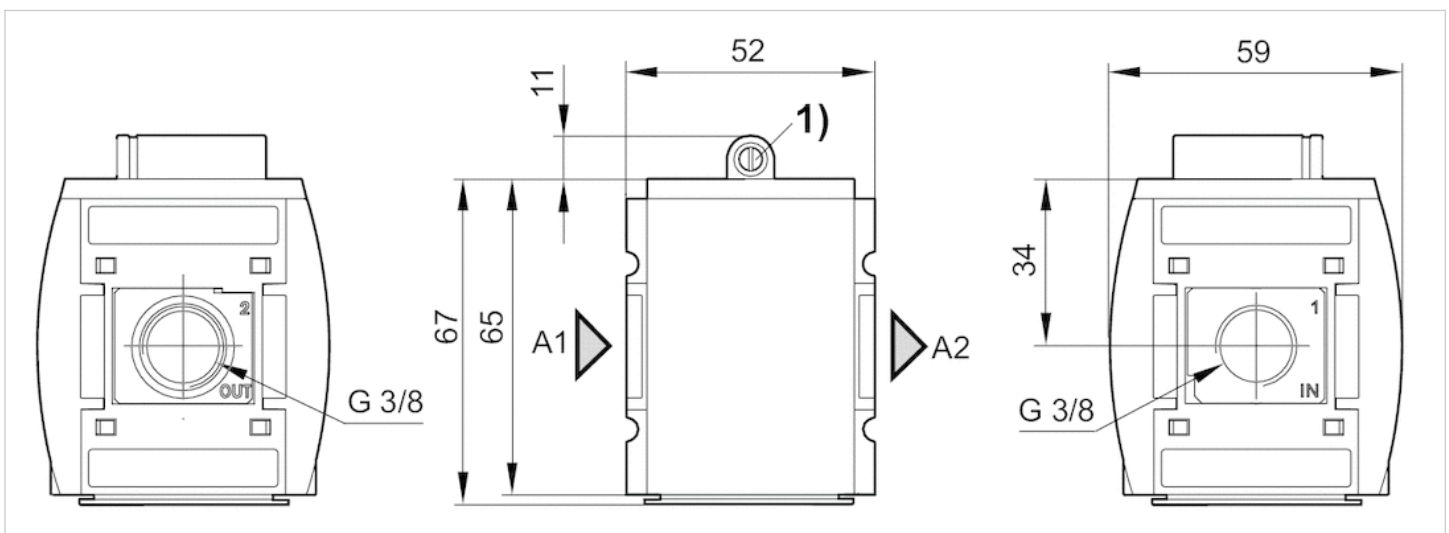

- A1 = input
- A2 = output

1) Adjustment screw for filling time

Diagrams

Secondary pressure while filling

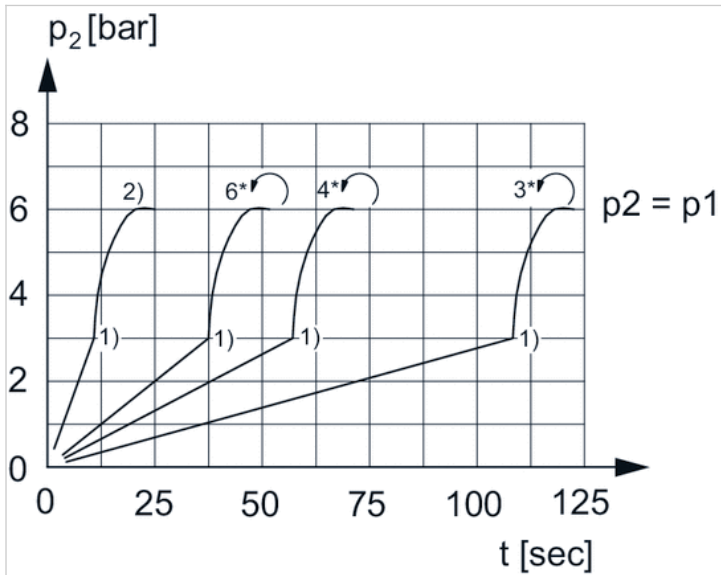

p1 = working pressure

p2 = secondary pressure

t = filling time, adjustable via adjustment screw (throttle)

1) Switching point: adjustable filling time, fixed change-over pressure $\approx 0.5 \times p1$ (50%)

2) Throttle fully opened

* Adjustment screw rotations

Flow rate characteristic

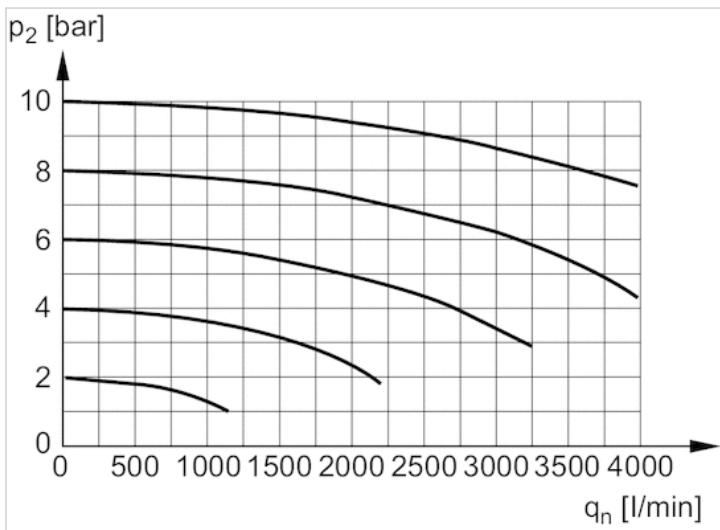

p2 = secondary pressure

qn = nominal flow

Accessories overview

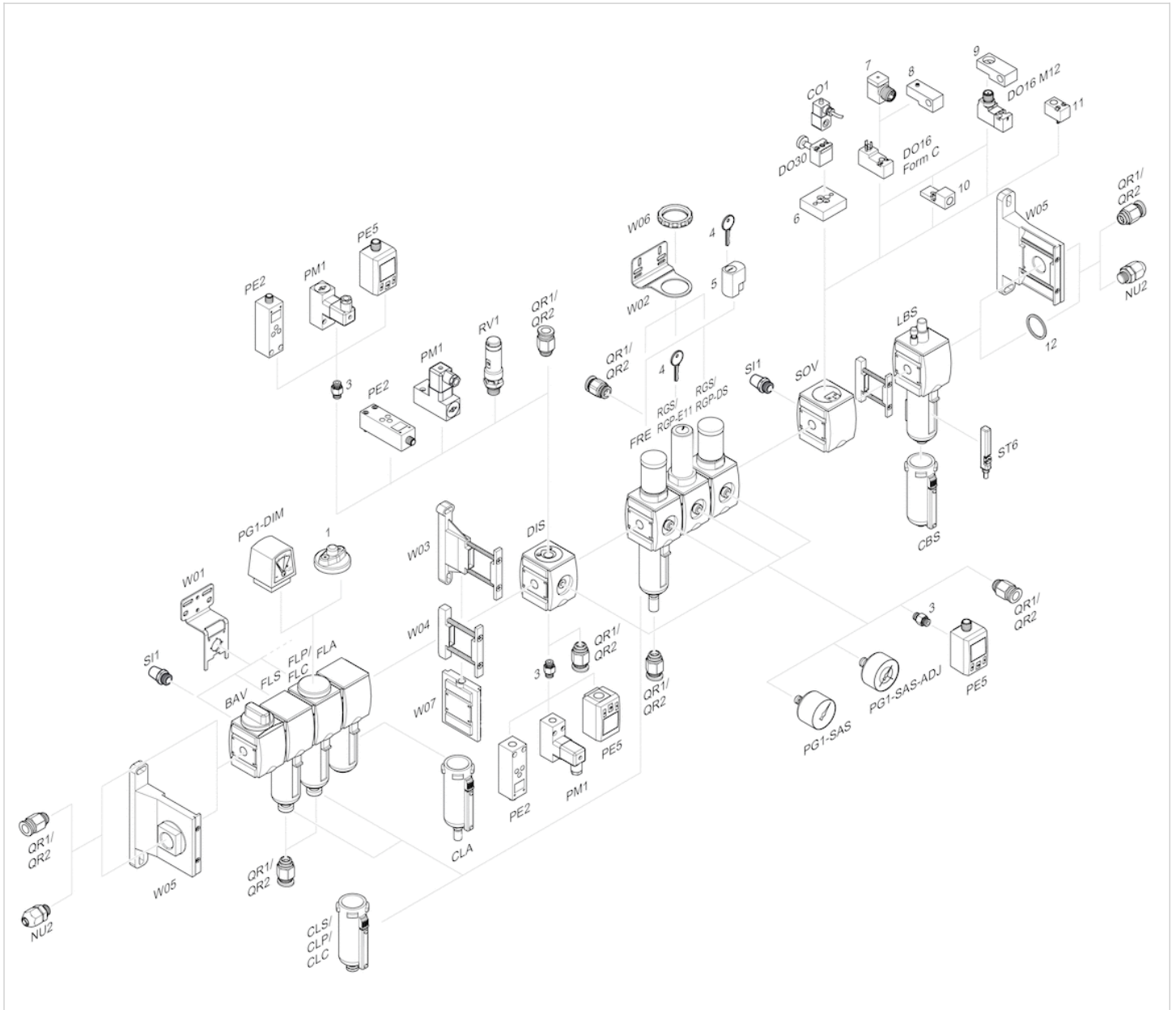

- 1 = contamination display
- 3 = Double nipple
- 4 = Key for E11 locking
- 5 = mortise lock
- 6 = Transition plate DO30
- 7 = Adapter, Series CON-VP
- 8 = Mounting aid DO16, form C
- 9 = Mounting aid DO16, M12
- 10 = Adapter for external pilot air
- 11 = Adapter pneumatic operation
- 12 = Sealing ring

Filling valve, pneumatically operated, Series AS2-SSV

- With pneumatic priority circuit, adjustable filling time.
- Compressed air connection G 1/4 G 3/8
- Pipe connection



Version	Poppet valve, Can be assembled into blocks
Sealing principle	Soft sealing
Working pressure min./max.	1 ... 16 bar
Ambient temperature min./max.	0 ... 50 °C
Medium temperature min./max.	0 ... 50 °C
Medium	Compressed air Neutral gases
Max. particle size	40 µm
Weight	0.314 kg

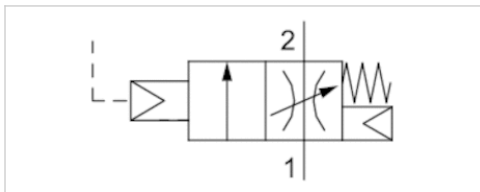

Technical data

Part No.	Port	Pilot connection	Flow	Fig.
			Qn 1▶2	
R412006311	G 1/4	G 1/8	1900 l/min	Fig. 1
R412006312	G 3/8	G 1/8	1900 l/min	Fig. 2

Nominal flow with secondary pressure 6.3 bar at $\Delta p = 1$ bar

Technical information

The pressure dew point must be at least 15 °C under ambient and medium temperature and may not exceed 3 °C .

A change in the flow direction (from air supply on the left to air supply on the right) occurs by rotating installation by 180° about the vertical axis. Please see the operating instructions for further details.

The filling valve builds up pressure slowly in the pneumatic systems, i.e. prevents a sudden pressure build-up during a recommissioning after a mains pressure failure or avoids emergency OFF switching. This allows dangerous abrupt cylinder motions to be avoided.

Actuating the electric priority circuit disrupts the slow pressure build-up and pressure p1 is immediately applied.

For unthrottled operation, the filling valve must be permanently electrically actuated.

Technical information

Material	
Housing	Polyamide
Front plate	Acrylonitrile butadiene styrene
Seals	Acrylonitrile butadiene rubber
Threaded bushing	Die cast zinc

Dimensions

Dimensions in mm, Fig. 1

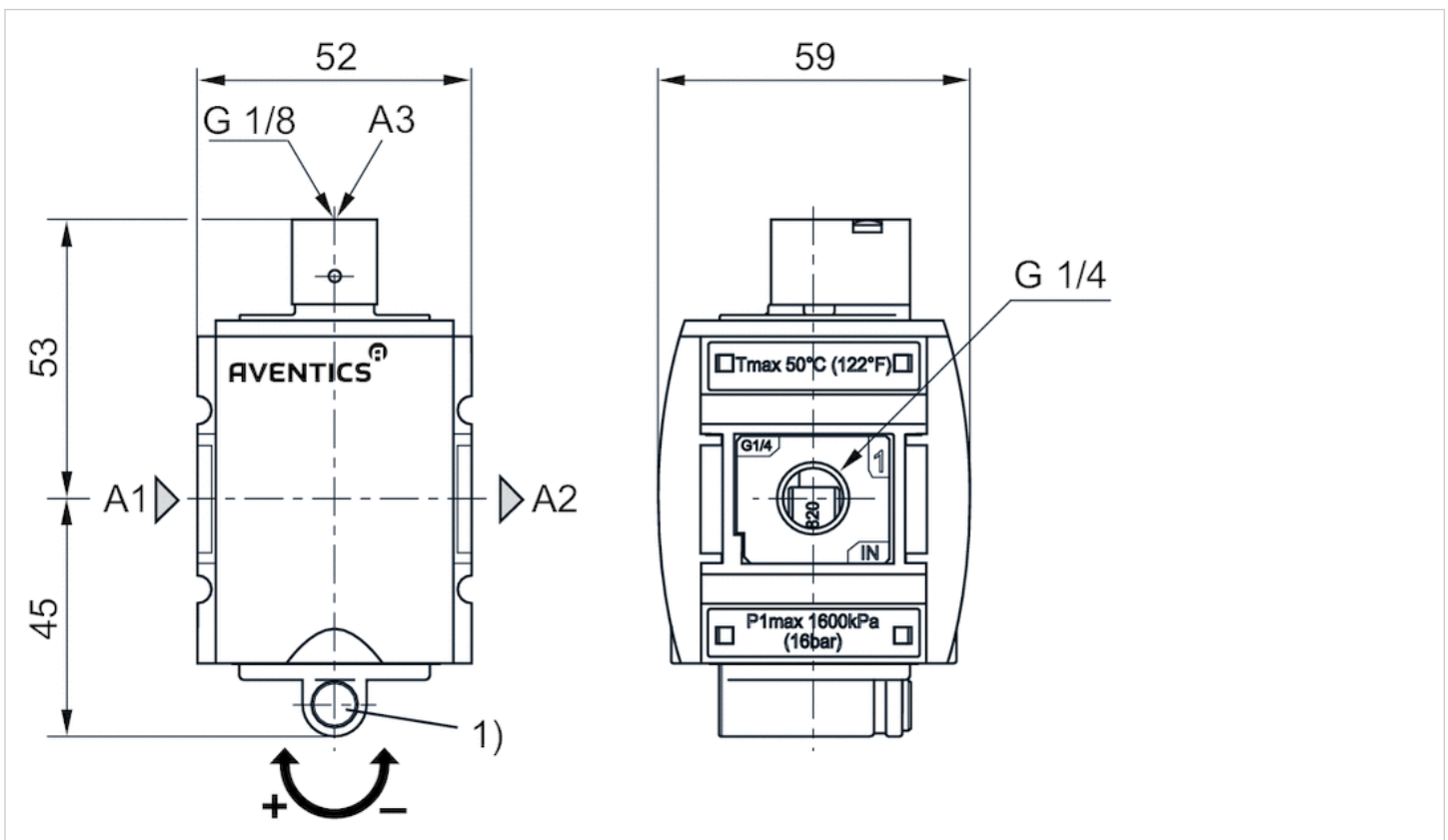

A1 = input

A2 = output

A3 = control pressure connection

1) Adjustment screw for filling time

Dimensions in mm, Fig. 2

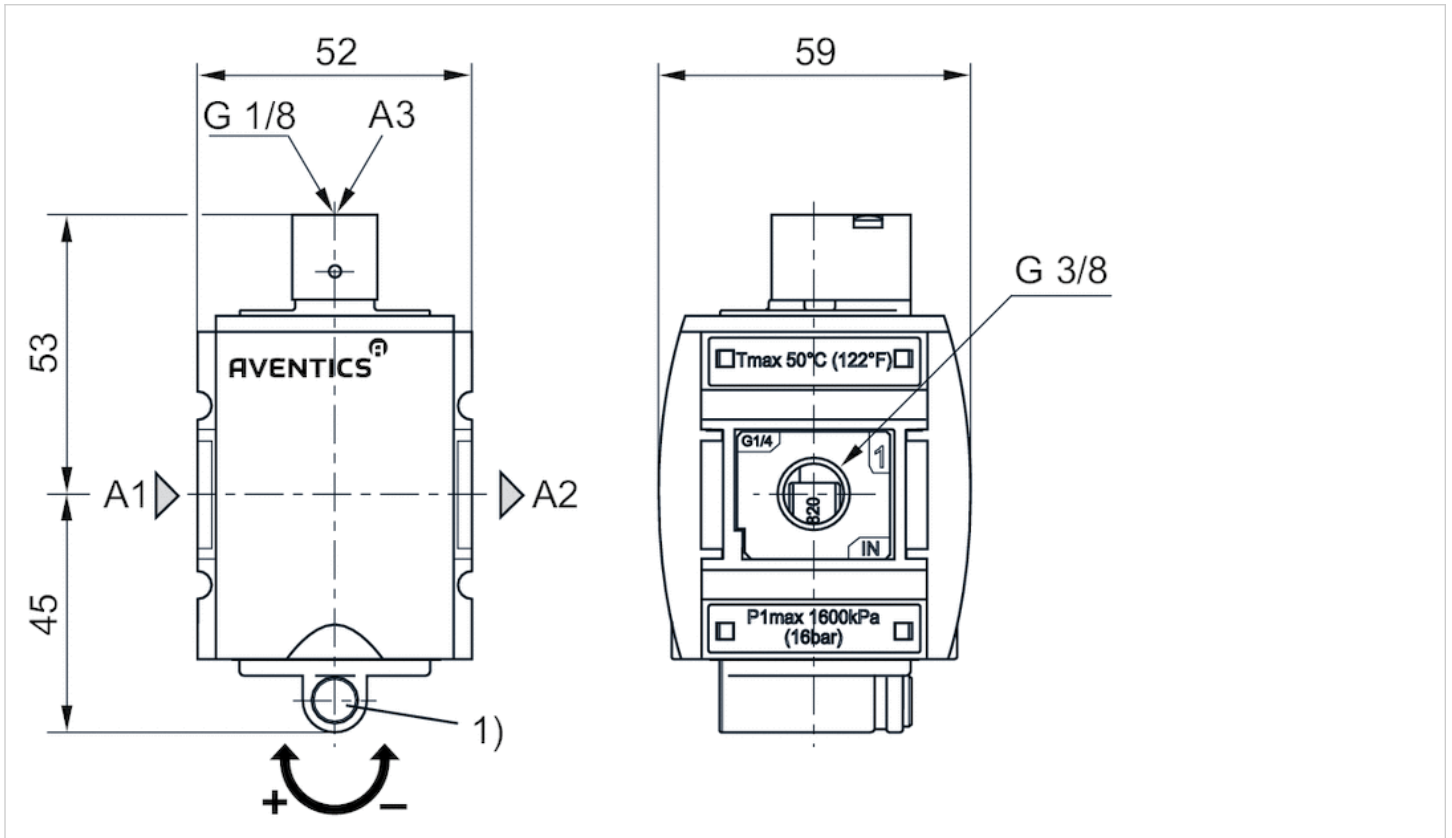

- A1 = input
- A2 = output
- A3 = control pressure connection
- 1) Adjustment screw for filling time

Diagrams

Secondary pressure while filling

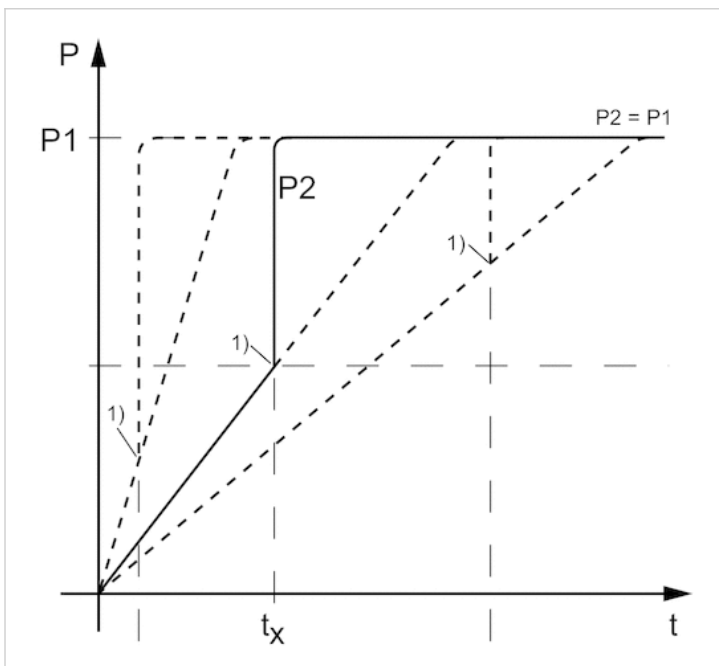

p1 = working pressure

p2 = output pressure
 t = filling time
 tx = switchover time
 1) Pneumatically triggered switching point
 Filling time adjustable via adjustment screw (throttle)

control pressure characteristic

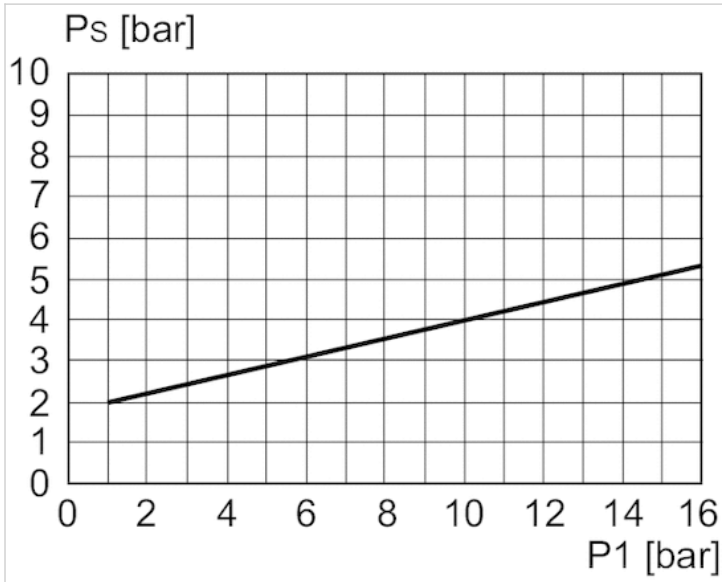

p1 = working pressure
 PS = control pressure

Flow rate characteristic

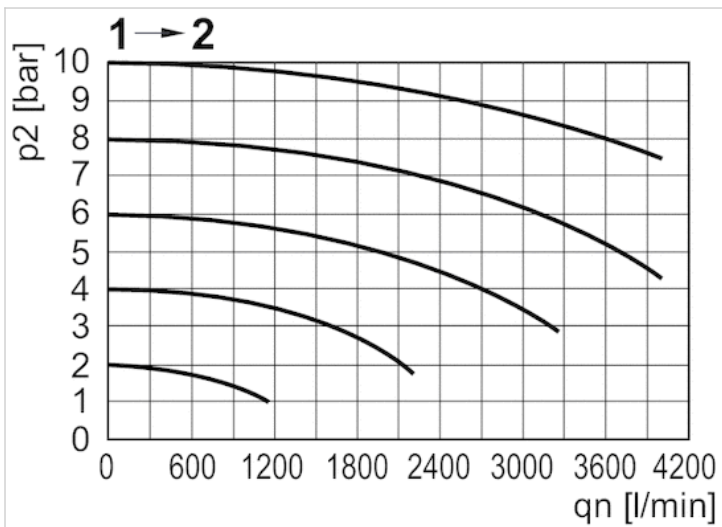

p2 = secondary pressure
 qn = nominal flow

Accessories overview

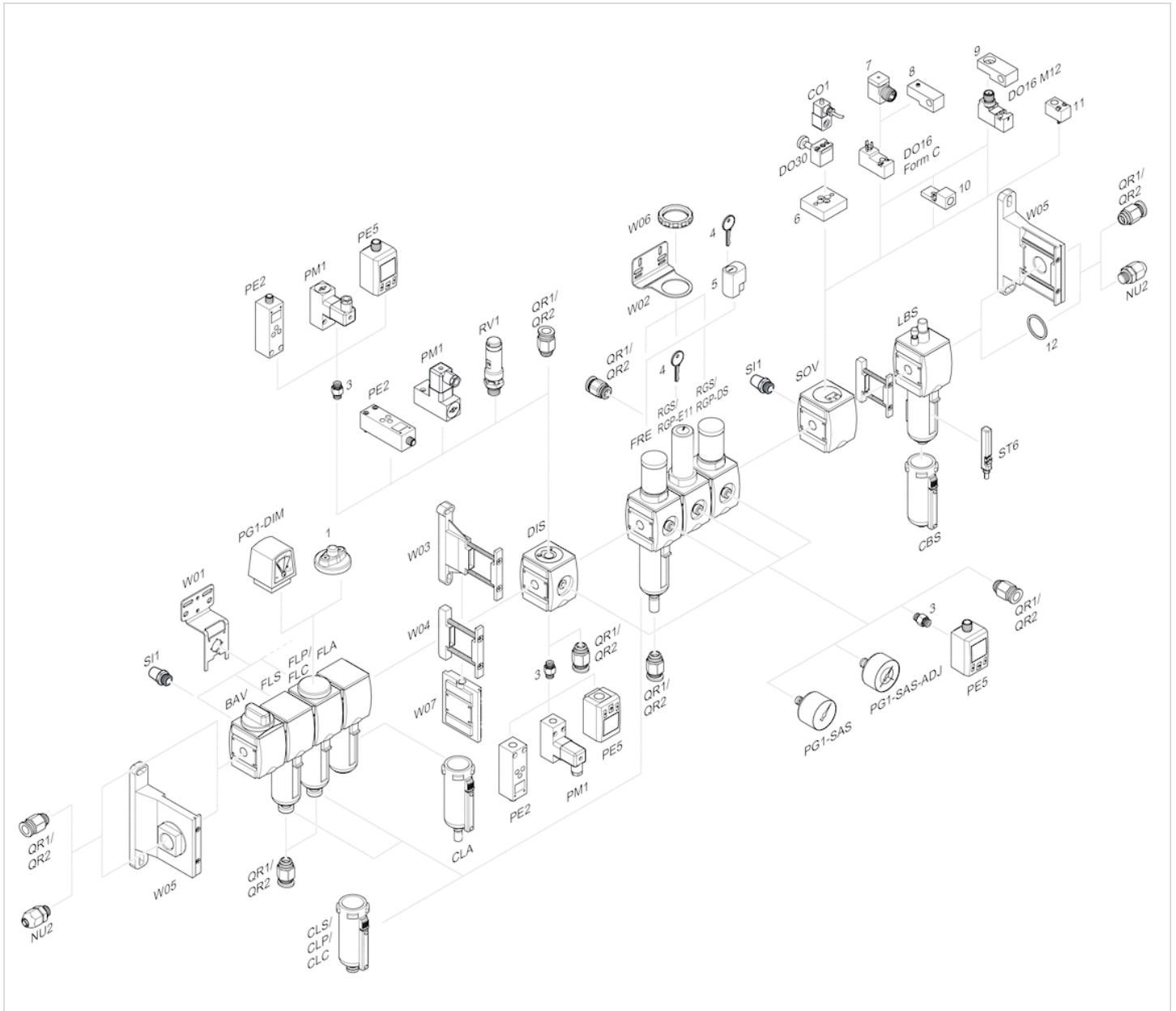

- 1 = contamination display
- 3 = Double nipple
- 4 = Key for E11 locking
- 5 = mortise lock
- 6 = Transition plate DO30
- 7 = Adapter, Series CON-VP
- 8 = Mounting aid DO16, form C
- 9 = Mounting aid DO16, M12
- 10 = Adapter for external pilot air
- 11 = Adapter pneumatic operation
- 12 = Sealing ring

Filling valve, mechanically adjustable, series AS2-SSV

- Adjustable filling time and change-over pressure.
- Compressed air connection G 1/4 G 3/8



Version	Poppet valve, Can be assembled into blocks
Sealing principle	Soft sealing
Working pressure min./max.	2.5 ... 16 bar
Ambient temperature min./max.	-10 ... 50 °C
Medium temperature min./max.	-10 ... 50 °C
Medium	Compressed air Neutral gases
Max. particle size	40 µm
Weight	0.203 kg

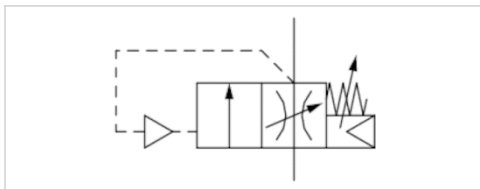

Technical data

Part No.	Port	Exhaust	Flow	Fig.
			Qn	
R412006245	G 1/4	G 3/8	2000 l/min	Fig. 1
R412006246	G 3/8	G 3/8	2000 l/min	Fig. 2

Nominal flow Qn with secondary pressure p2 = 6 bar at Δp = 1 bar

Technical information

The pressure dew point must be at least 15 °C under ambient and medium temperature and may not exceed 3 °C .

The filling valve builds up pressure slowly in the pneumatic systems, i.e. prevents a sudden pressure build-up during a recommissioning after a mains pressure failure or avoids emergency OFF switching. This allows dangerous abrupt cylinder motions to be avoided.

Adjustable filling time and change-over pressure.

Do not position filling valves or filling units upstream of open consumers, such as nozzles, air barriers, air curtains, since these may prevent through connection of components.

A change in the flow direction (from air supply on the left to air supply on the right) occurs by rotating installation by 180° about the vertical axis. Please see the operating instructions for further details.

Technical information

Material

Housing	Polyamide
Front plate	Acrylonitrile butadiene styrene

Material	
Seals	Acrylonitrile butadiene rubber
Threaded bushing	Die cast zinc

Dimensions

Dimensions in mm, Fig. 1

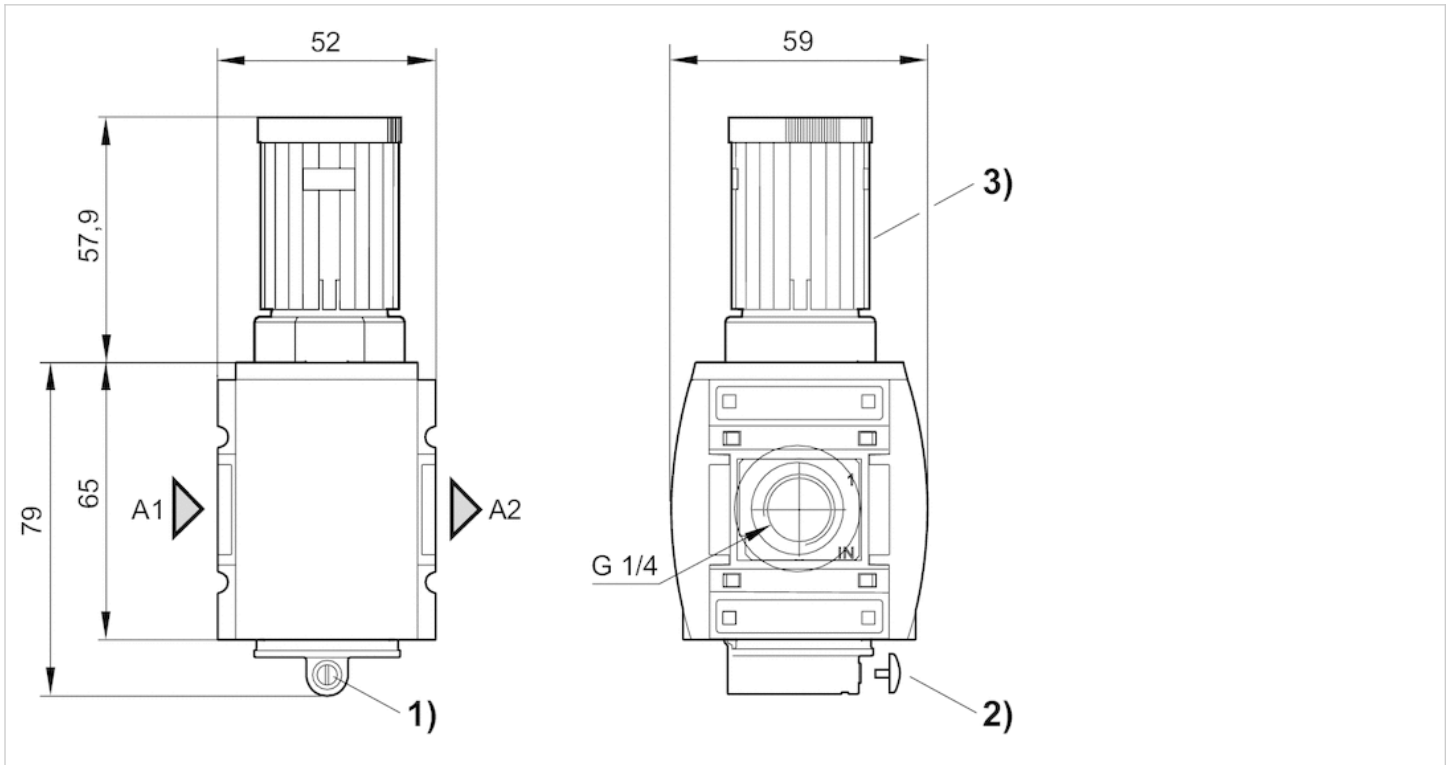

- A1 = input
- A2 = output
- 1) Adjustment screw for filling time
- 2) Adjustment screw lock
- 3) handwheel for change-over pressure

Dimensions in mm, Fig. 2

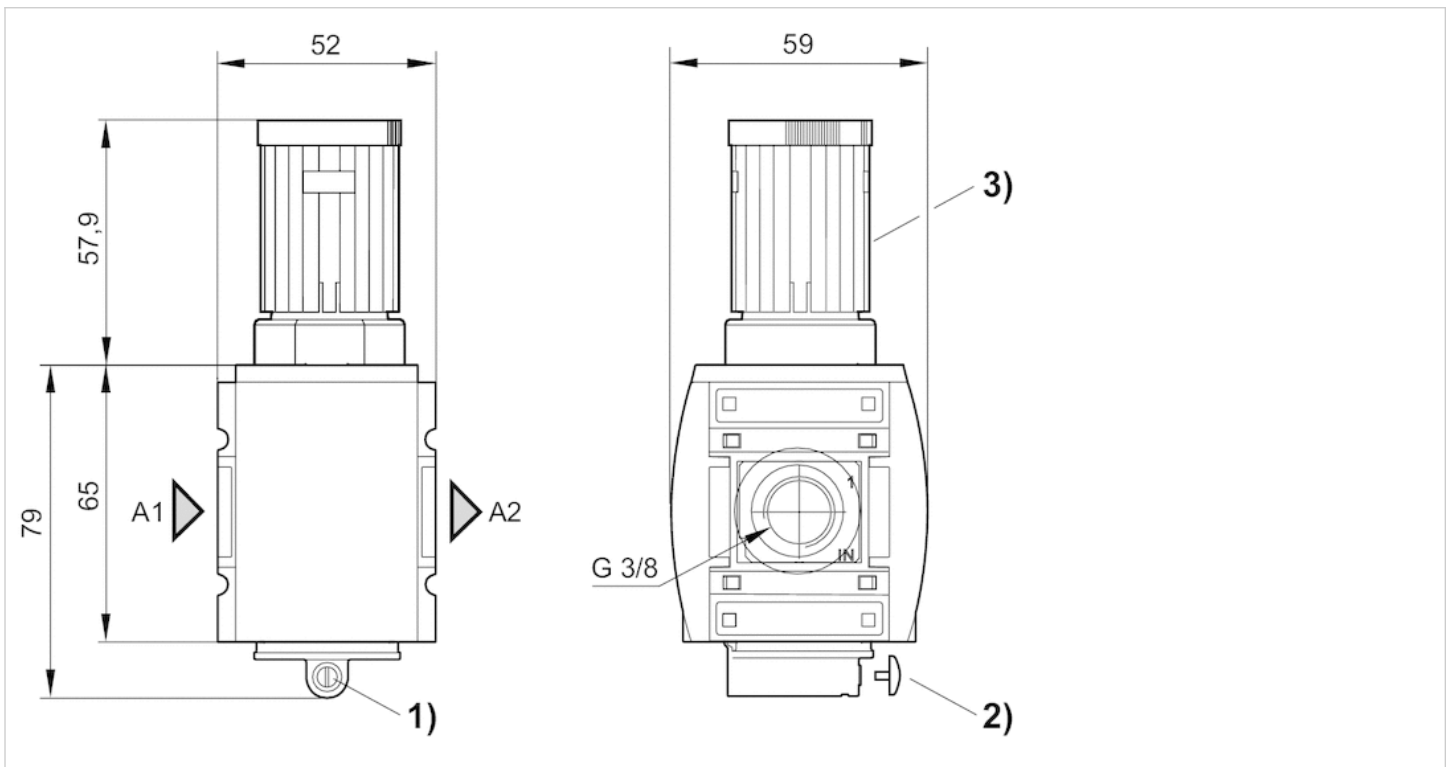

- A1 = input
- A2 = output
- 1) Adjustment screw for filling time
- 2) Adjustment screw lock
- 3) handwheel for change-over pressure

Diagrams

Secondary pressure while filling

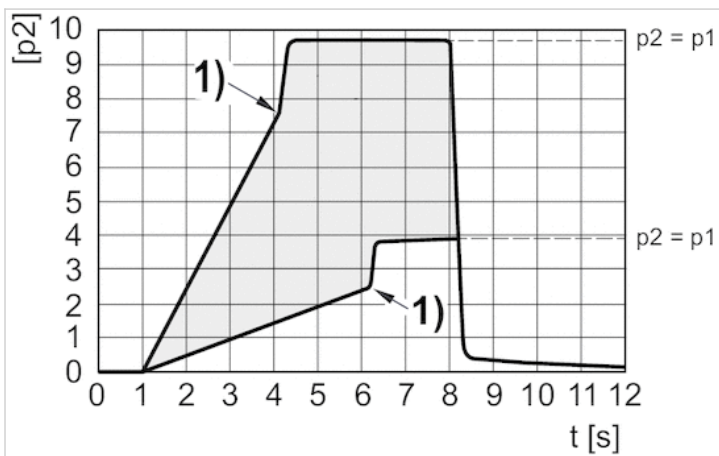

- p1 = working pressure
- p2 = secondary pressure
- t = filling time, adjustable via adjustment screw (throttle)
- Change-over pressure individually adjustable via handwheel
- 1) Switching point: adjustable filling time and change-over pressure

Flow rate characteristic

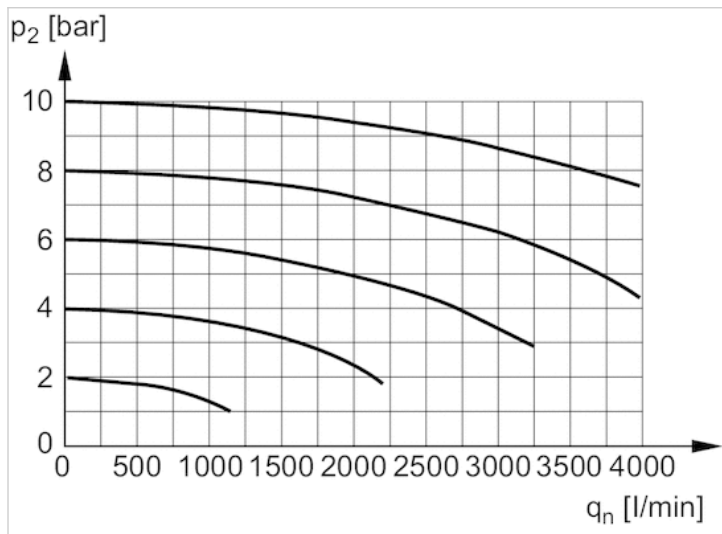

p_2 = secondary pressure
 q_n = nominal flow

Accessories overview

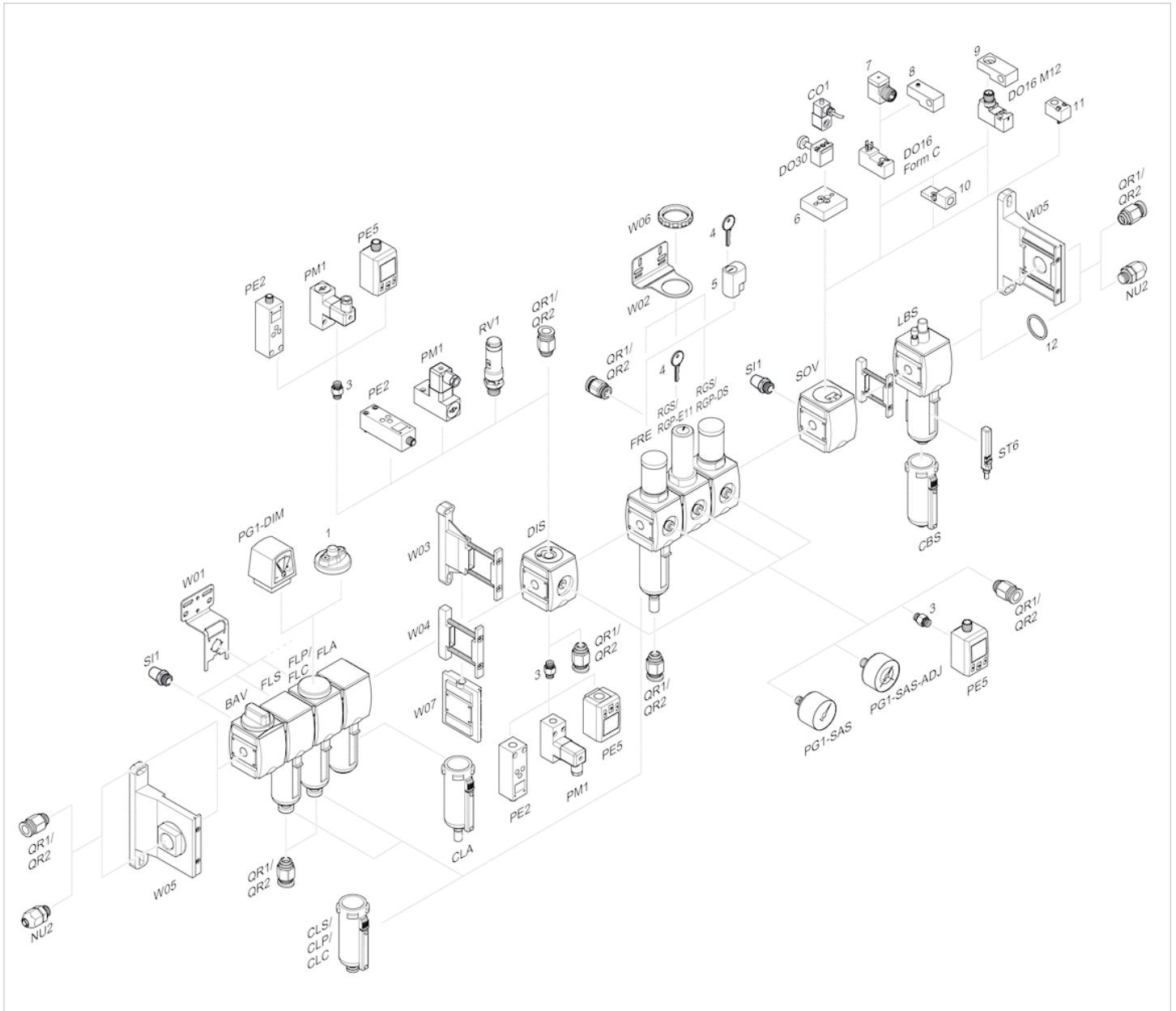

- 1 = contamination display
- 3 = Double nipple
- 4 = Key for E11 locking
- 5 = mortise lock
- 6 = Transition plate DO30
- 7 = Adapter, Series CON-VP
- 8 = Mounting aid DO16, form C
- 9 = Mounting aid DO16, M12
- 10 = Adapter for external pilot air
- 11 = Adapter pneumatic operation
- 12 = Sealing ring

Filling valve, electrically operated, series AS2-SSV

- With electrical priority circuit, adjustable filling time.
- Compressed air connection G 1/4
- Electrical connection: Plug, M12x1

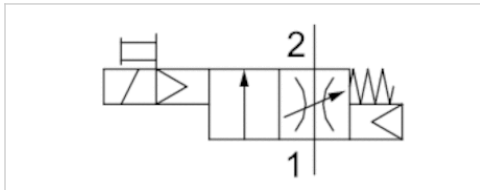

Version	Poppet valve with elect. priority circuit, Can be assembled into blocks
Parts	Filling valve
Nominal flow	2000 l/min
Working pressure min./max.	2.5 ... 10 bar
Medium	Compressed air Neutral gases
Medium temperature min./max.	-10 ... 50 °C
Ambient temperature min./max.	-10 ... 50 °C
Sealing principle	Soft sealing
Max. particle size	25 µm
Protection class acc. to DIN EN 61140 with plug	IP65
Duty cycle	100 %
Weight	0.203 kg

Technical data

Part No.	Compressed air connection input	Compressed air connection output	Electrical connection
			Pilot valve
R412006379	G 1/4	G 1/4	Plug, M12x1

Nominal flow Q_n with secondary pressure $p_2 = 6$ bar at $\Delta p = 1$ bar, Electr. connection: valve plug connector M12x1

Technical information

The pressure dew point must be at least 15 °C under ambient and medium temperature and may not exceed 3 °C .

A change in the flow direction (from air supply on the left to air supply on the right) occurs by rotating installation by 180° about the vertical axis. Please see the operating instructions for further details.

The filling valve builds up pressure slowly in the pneumatic systems, i.e. prevents a sudden pressure build-up during a recommissioning after a mains pressure failure or avoids emergency OFF switching. This allows dangerous abrupt cylinder motions to be avoided.

Actuating the electric priority circuit disrupts the slow pressure build-up and pressure p_1 is immediately applied.

For unthrottled operation, the filling valve must be permanently electrically actuated.

Technical information

Material	
Housing	Polyamide
Front plate	Acrylonitrile butadiene styrene

Material	
Seals	Acrylonitrile butadiene rubber
Threaded bushing	Die cast zinc

Dimensions

Dimensions in mm

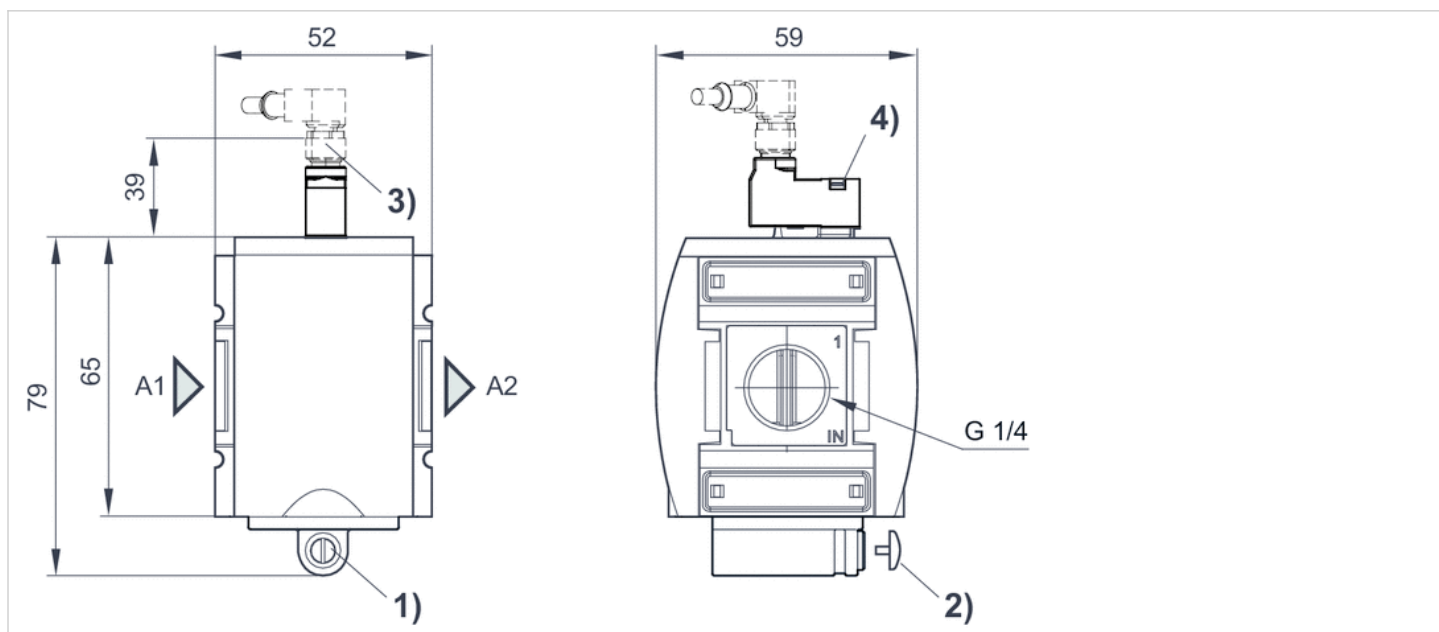

A1 = input

A2 = output

1) Adjustment screw for filling time

2) Adjustment screw lock

3) plug M12

4) Manual override

Diagrams

secondary pressure while filling

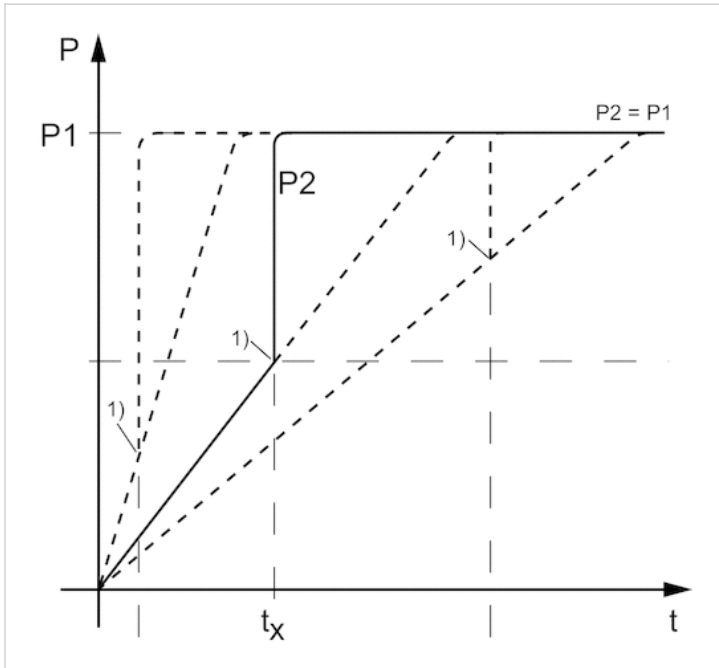

- p1 = working pressure
 - p2 = secondary pressure
 - t = filling time
 - t_x = switchover time
 - 1) Electrically triggered switching point
- Filling time adjustable via adjustment screw (throttle)

Flow rate characteristic

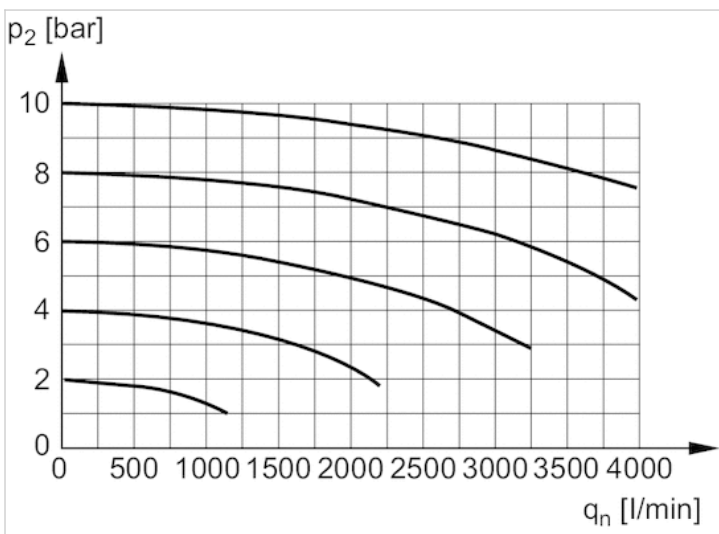

- p_2 = secondary pressure
- q_n = nominal flow

Pin assignments

Pin assignment M12x1

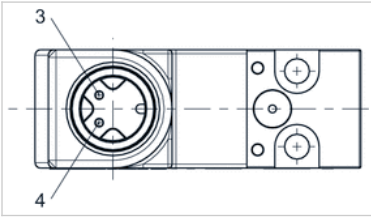

- 3: +/-
- 4: +/-

Accessories overview

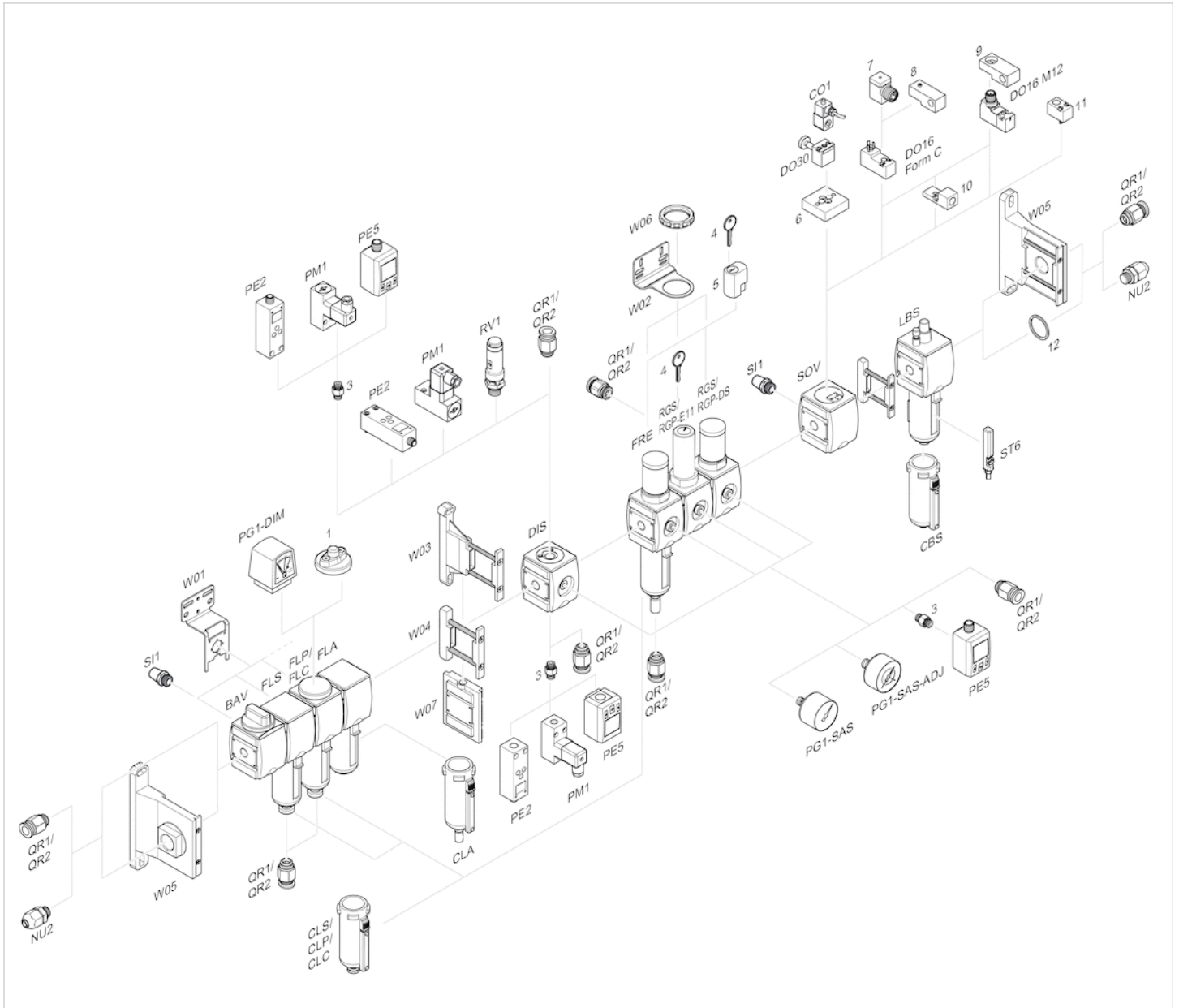

1 = contamination display

- 3 = Double nipple
- 4 = Key for E11 locking
- 5 = mortise lock
- 6 = Transition plate DO30
- 7 = Adapter, Series CON-VP
- 8 = Mounting aid DO16, form C
- 9 = Mounting aid DO16, M12
- 10 = Adapter for external pilot air
- 11 = Adapter pneumatic operation
- 12 = Sealing ring

2/2-directional valve, electrically operated, Series AS2-SOV

- Compressed air connection G 3/8
- Pipe connection
- NC
- Electrical connection: Plug, ISO 15217, form C

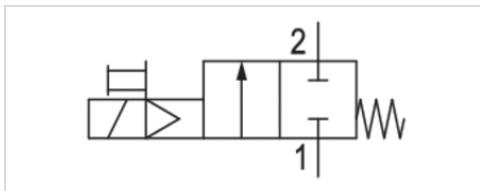

Version	Poppet valve, Can be assembled into blocks
Parts	2/2-directional valve, electrically operated
Nominal flow	2000 l/min
Working pressure min./max.	2.5 ... 10 bar
Medium	Compressed air Neutral gases
Medium temperature min./max.	-10 ... 50 °C
Ambient temperature min./max.	-10 ... 50 °C
Sealing principle	Soft sealing
Max. particle size	25 µm
Protection class acc. to DIN EN 61140 with plug	IP65
Duty cycle	100 %
Weight	0.291 kg

Technical data

Part No.			Compressed air connection input	Compressed air connection output
R412006294		NC	G 3/8	G 3/8

Part No.	Operational voltage	Power consumption	Electrical connection
		DC	Pilot valve
R412006294	DC 24 V	DC 2 W	Plug, ISO 15217, form C

Part No.	basic valve with electrical connector	Reverse polarity protection
R412006294	Basic valve with pilot valve	Protected against polarity reversal

Nominal flow Q_n with secondary pressure $p_2 = 6$ bar at $\Delta p = 1$ bar

Technical information

The pressure dew point must be at least 15 °C under ambient and medium temperature and may not exceed 3 °C .
A change in the flow direction (from air supply on the left to air supply on the right) occurs by rotating installation by 180° about the vertical axis. Please see the operating instructions for further details.

Technical information

Material	
Housing	Polyamide
Front plate	Acrylonitrile butadiene styrene
Seals	Acrylonitrile butadiene rubber
Threaded bushing	Die cast zinc

Dimensions

Dimensions in mm

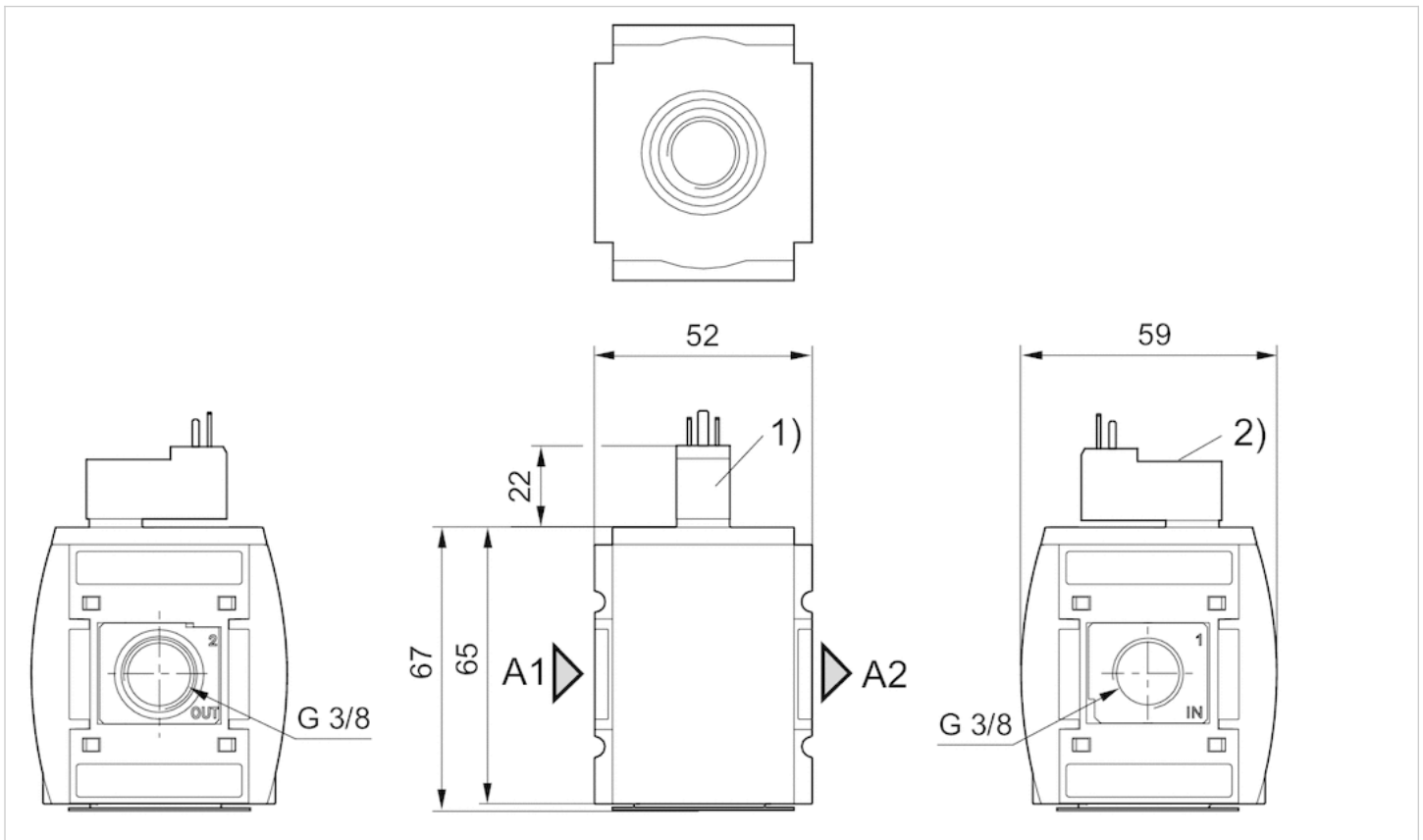

A1 = input

A2 = output

1) Connection for valve plug connector according to ISO 15217 (form C)

2) Manual override

Diagrams

Flow rate characteristic

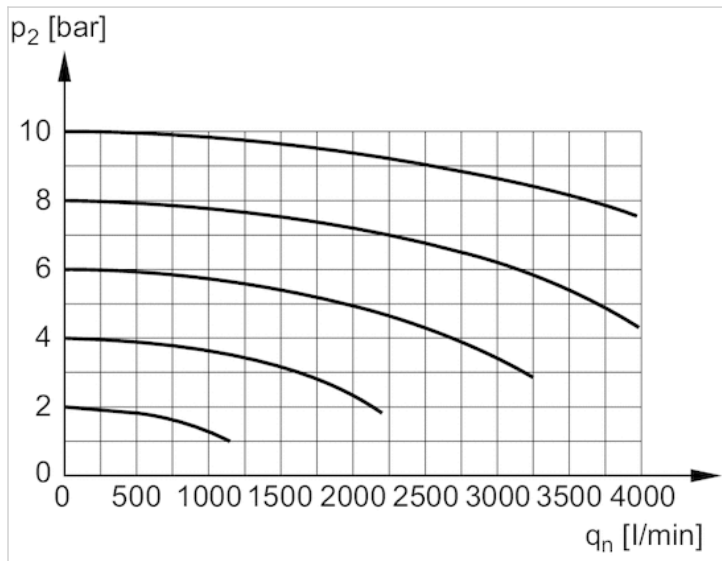

p_2 = secondary pressure
 q_n = nominal flow

Accessories overview

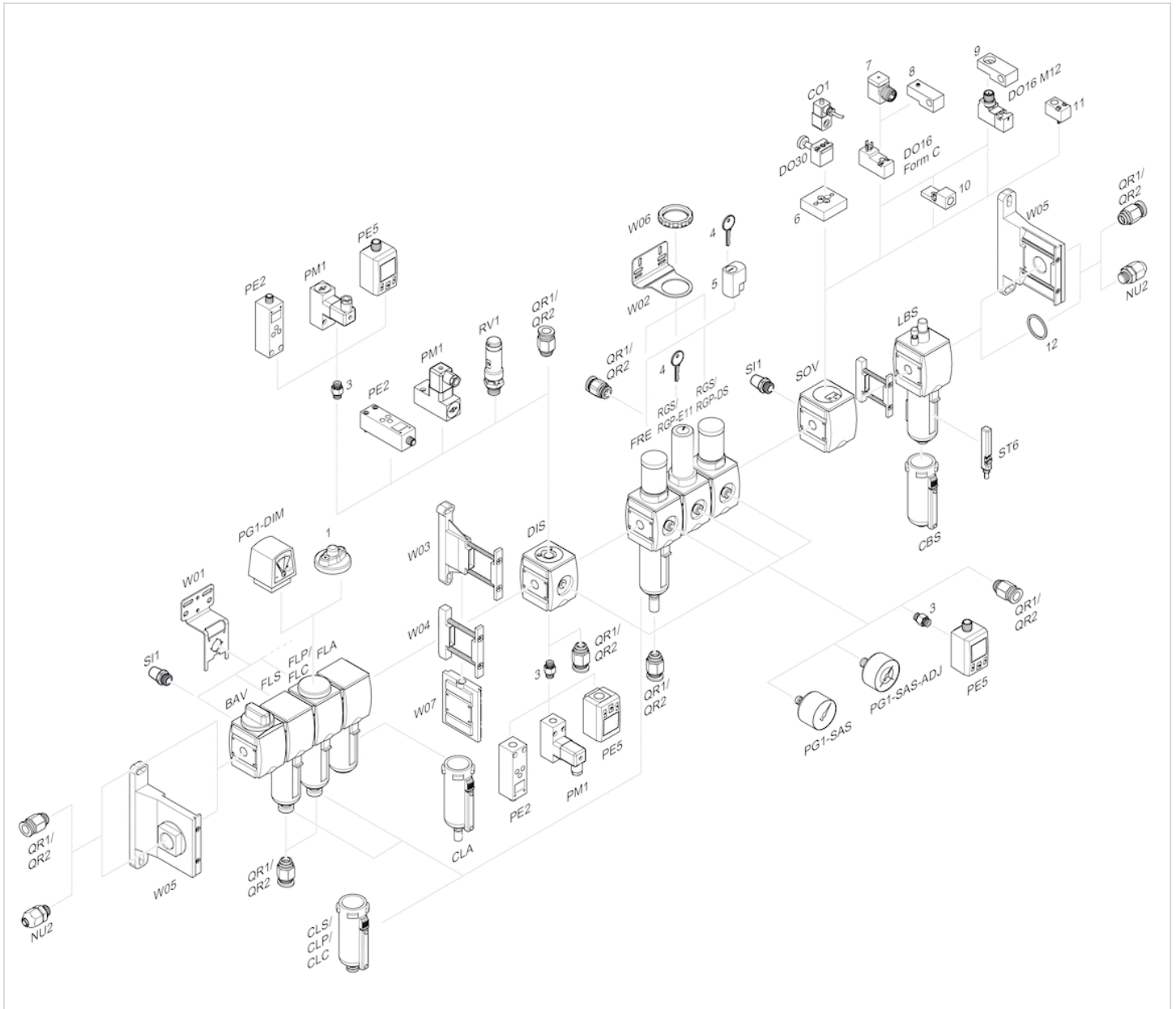

- 1 = contamination display
- 3 = Double nipple
- 4 = Key for E11 locking
- 5 = mortise lock
- 6 = Transition plate DO30
- 7 = Adapter, Series CON-VP
- 8 = Mounting aid DO16, form C
- 9 = Mounting aid DO16, M12
- 10 = Adapter for external pilot air
- 11 = Adapter pneumatic operation
- 12 = Sealing ring





















3/2-directional valve, electrically operated, Series AS2-SOV

- Compressed air connection G 1/4 G 3/8
- Pipe connection
- ATEX optional



Version	Poppet valve, Can be assembled into blocks
Parts	3/2-directional valve, electrically operated
Nominal flow	See table below
Nominal flow 1 ▶ 2	2000 l/min
Nominal flow 2 ▶ 3	380 l/min
Working pressure min./max.	See table below
Medium	Compressed air Neutral gases
Medium temperature min./max.	-10 ... 50 °C
Ambient temperature min./max.	-10 ... 50 °C
Sealing principle	Soft sealing
Max. particle size	25 µm
Protection class acc. to DIN EN 61140 with plug	See table below
Weight	0.219 kg

Technical data

Part No.			Compressed air connection input	Compressed air connection output	Exhaust
R412006264		—	G 1/4	G 1/4	G 1/4
R412006268		—	G 3/8	G 3/8	G 1/4
R412006258		—	G 1/4	G 1/4	G 1/4
R412006259		—	G 3/8	G 3/8	G 1/4
R412006265			G 1/4	G 1/4	G 1/4
R412006266			G 1/4	G 1/4	G 1/4
R412006267			G 1/4	G 1/4	G 1/4
R412006269			G 3/8	G 3/8	G 1/4
R412006270			G 3/8	G 3/8	G 1/4
R412006271			G 3/8	G 3/8	G 1/4
R412006380			G 1/4	G 1/4	G 1/4
R412006381			G 3/8	G 3/8	G 1/4

Part No.	Operational voltage		Operational voltage
	DC	AC 50 Hz	AC 60 Hz
R412006264	-	-	-
R412006268	-	-	-
R412006258	-	-	-
R412006259	-	-	-
R412006265	24 V	-	-
R412006266	-	110 V	110 V
R412006267	-	220 V	230 V
R412006269	24 V	-	-

Part No.	Operational voltage	Operational voltage	Operational voltage
	DC	AC 50 Hz	AC 60 Hz
R412006270	-	110 V	110 V
R412006271	-	220 V	230 V
R412006380	24 V	-	-
R412006381	24 V	-	-

Part No.	Power consumption	Holding power	Holding power	Switch-on power
	DC	AC 50 Hz	AC 60 Hz	AC 50 Hz
R412006264	-	-	-	-
R412006268	-	-	-	-
R412006258	-	-	-	-
R412006259	-	-	-	-
R412006265	2 W	-	-	-
R412006266	-	1.6 VA	1.4 VA	2.2 VA
R412006267	-	1.6 VA	1.4 VA	2.2 VA
R412006269	2 W	-	-	-
R412006270	-	1.6 VA	1.4 VA	2.2 VA
R412006271	-	1.6 VA	1.4 VA	2.2 VA
R412006380	2 W	-	-	-
R412006381	2 W	-	-	-

Part No.	Switch-on power	Flow	Working pressure min./max.	Protection class
	AC 60 Hz	Qn		
R412006264	-	2000 l/min	2.5 ... 16 bar	-
R412006268	-	2000 l/min	2.5 ... 16 bar	-
R412006258	-	2000 l/min	2.5 ... 16 bar	-
R412006259	-	2000 l/min	2.5 ... 16 bar	-
R412006265	-	2000 l/min	2.5 ... 10 bar	IP65
R412006266	1.6 VA	2000 l/min	2.5 ... 10 bar	IP65
R412006267	1.6 VA	2000 l/min	2.5 ... 10 bar	IP65
R412006269	-	2000 l/min	2.5 ... 10 bar	IP65
R412006270	1.6 VA	2000 l/min	2.5 ... 10 bar	IP65
R412006271	1.6 VA	2000 l/min	2.5 ... 10 bar	IP65
R412006380	-	2000 l/min	2.5 ... 10 bar	IP65
R412006381	-	-	2.5 ... 10 bar	IP65

Part No.	Electrical connection	Connector standard
	Pilot valve	
R412006264	-	-
R412006268	-	-
R412006258	-	-
R412006259	-	-
R412006265	Plug, ISO 15217, form C	ISO 15217
R412006266	Plug, ISO 15217, form C	ISO 15217
R412006267	Plug, ISO 15217, form C	ISO 15217
R412006269	Plug, ISO 15217, form C	ISO 15217
R412006270	Plug, ISO 15217, form C	ISO 15217
R412006271	Plug, ISO 15217, form C	ISO 15217
R412006380	Plug, M12x1	-

Part No.	Electrical connection	Connector standard
	Pilot valve	
R412006381	Plug, M12x1	-

Part No.	basic valve with electrical connector
R412006264	Basic valve without pilot valve
R412006268	Basic valve without pilot valve
R412006258	Basic valve without pilot valve, with CNOMO subbase
R412006259	Basic valve without pilot valve, with CNOMO subbase
R412006265	Basic valve with pilot valve
R412006266	Basic valve with pilot valve
R412006267	Basic valve with pilot valve
R412006269	Basic valve with pilot valve
R412006270	Basic valve with pilot valve
R412006271	Basic valve with pilot valve
R412006380	Basic valve with pilot valve
R412006381	Basic valve with pilot valve

Part No.	Reverse polarity protection	Fig.	
R412006264	-	Fig. 1	1)
R412006268	-	Fig. 2	1)
R412006258	-	Fig. 3	1)
R412006259	-	Fig. 4	1)
R412006265	Protected against polarity reversal	Fig. 5	-
R412006266	Protected against polarity reversal	Fig. 5	-
R412006267	Protected against polarity reversal	Fig. 5	-
R412006269	Protected against polarity reversal	Fig. 6	-
R412006270	Protected against polarity reversal	Fig. 6	-
R412006271	Protected against polarity reversal	Fig. 6	-
R412006380	-	Fig. 7	-
R412006381	-	Fig. 8	-

Nominal flow Q_n with secondary pressure $p_2 = 6$ bar at $\Delta p = 1$ bar

1) Suitable for use in Ex zones 1, 2, 21, 22.

Technical information

The pressure dew point must be at least 15 °C under ambient and medium temperature and may not exceed 3 °C .

A change in the flow direction (from air supply on the left to air supply on the right) occurs by rotating installation by 180° about the vertical axis. Please see the operating instructions for further details.

ATEX optional: The ATEX ID depends on the selected pilot valve.

A short silencer is required for wall mounting (see accessories e.g. R412004817).

Technical information

Material	
Housing	Polyamide
Front plate	Acrylonitrile butadiene styrene

Material	
Seals	Acrylonitrile butadiene rubber
Threaded bushing	Die cast zinc

Dimensions

Dimensions in mm, Fig. 1, 3/2-directional valve without pilot valve with porting configuration for series DO16

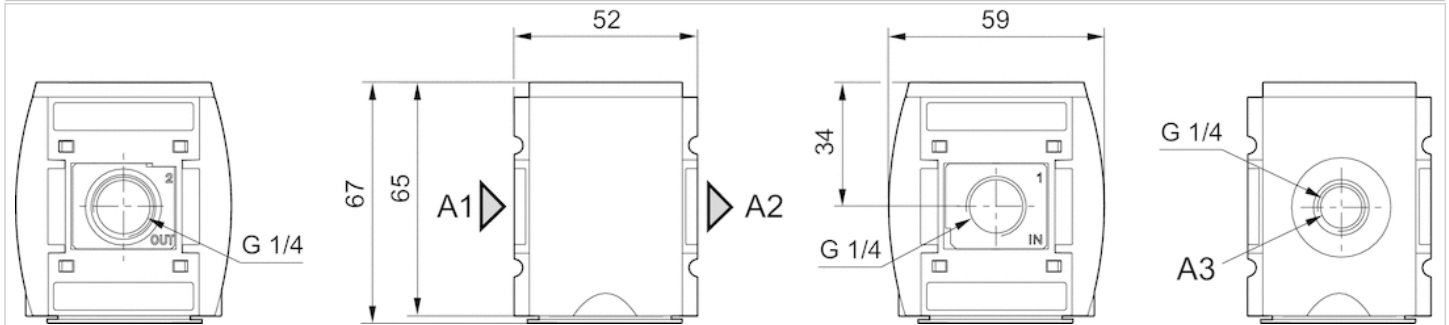

- A1 = input
- A2 = output
- A3 = ventilation port

Dimensions in mm, Fig. 2, 3/2-directional valve without pilot valve with porting configuration for series DO16

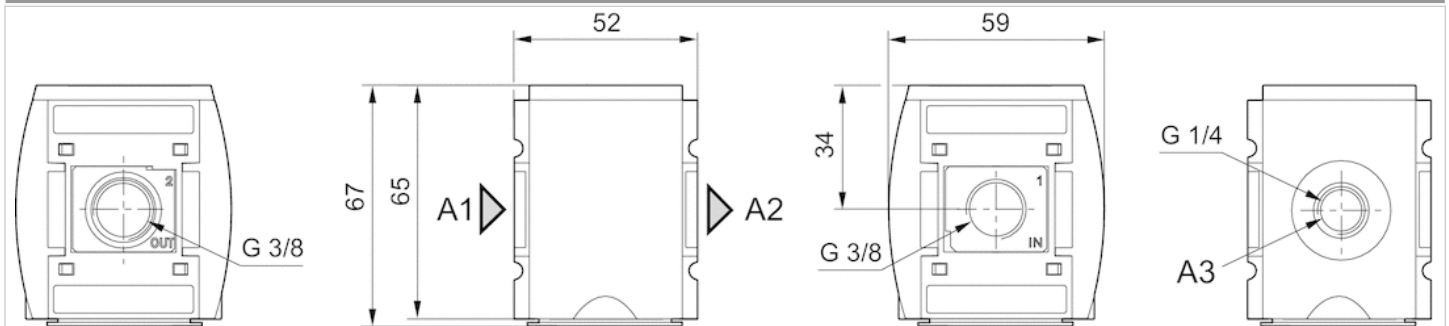

- A1 = input
- A2 = output
- A3 = ventilation port

Dimensions in mm, Fig. 3, 3/2 directional valve with transition plate (suitable for ATEX)

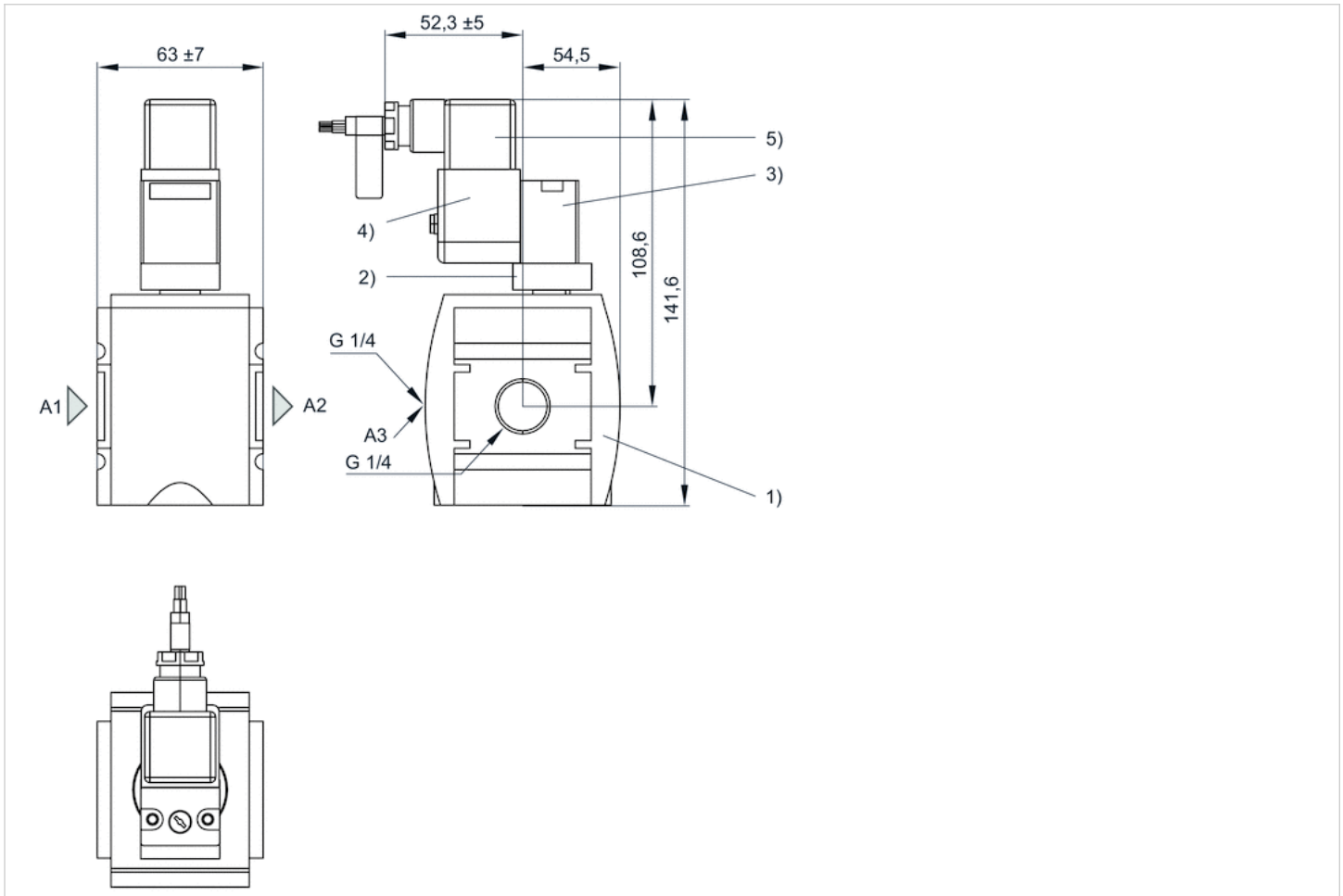

- A1 = input
 - A2 = output
 - A3 = ventilation port
 - 1) Shut-off valve
 - 2) Transition plate
 - 3) Pilot valve
 - 4) Coil
 - 5) Electrical connector
- See accessories for pilot valve and coil

Dimensions in mm, Fig. 4, 3/2 directional valve with transition plate (suitable for ATEX)

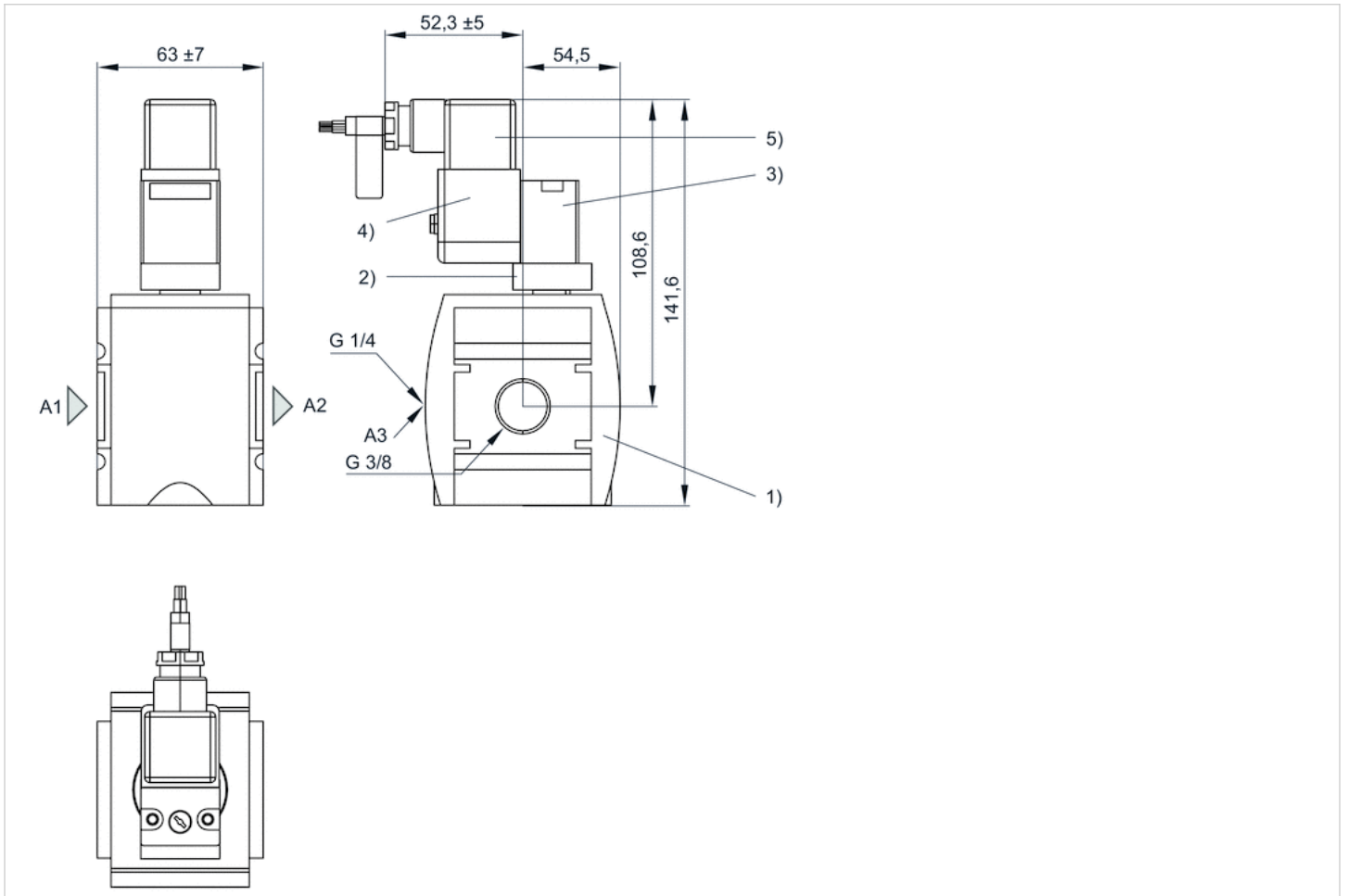

- A1 = input
 - A2 = output
 - A3 = ventilation port
 - 1) Shut-off valve
 - 2) Transition plate
 - 3) Pilot valve
 - 4) Coil
 - 5) Electrical connector
- See accessories for pilot valve and coil

Dimensions in mm, Fig. 5, 3/2-directional valve with pilot valve and port for electrical connector form C

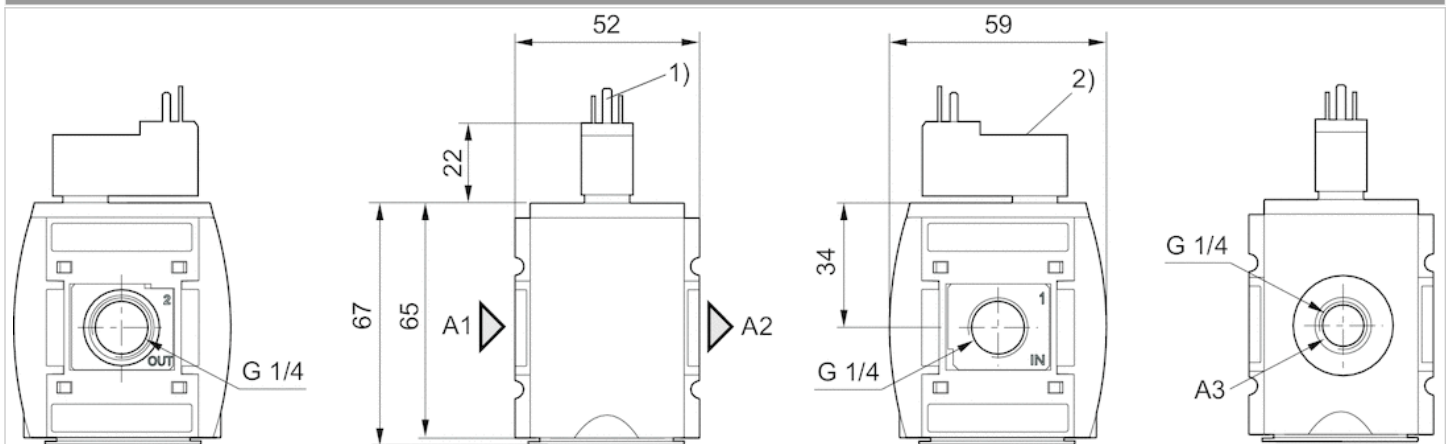

- A1 = input

- A2 = output
- A3 = ventilation port
- 1) For valve plug connectors according to ISO 15217 (form C)
- 2) Manual override

Dimensions in mm, Fig. 6, 3/2-directional valve with pilot valve and port for electrical connector form C

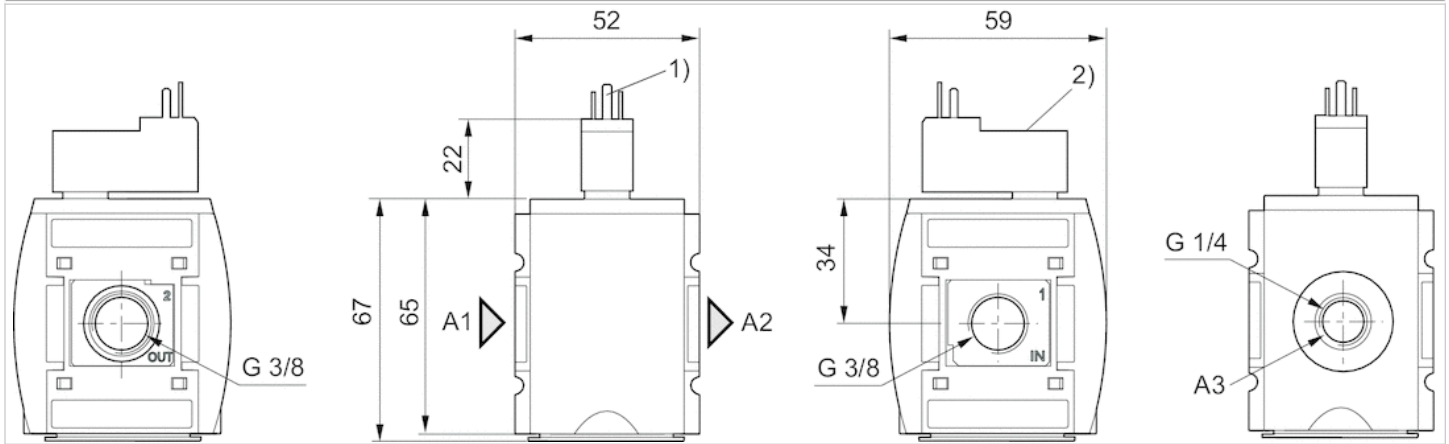

- A1 = input
- A2 = output
- A3 = ventilation port
- 1) For valve plug connectors according to ISO 15217 (form C)
- 2) Manual override

Dimensions in mm, Fig. 7, 3/2-directional valve with pilot valve, push-in fitting M12x1

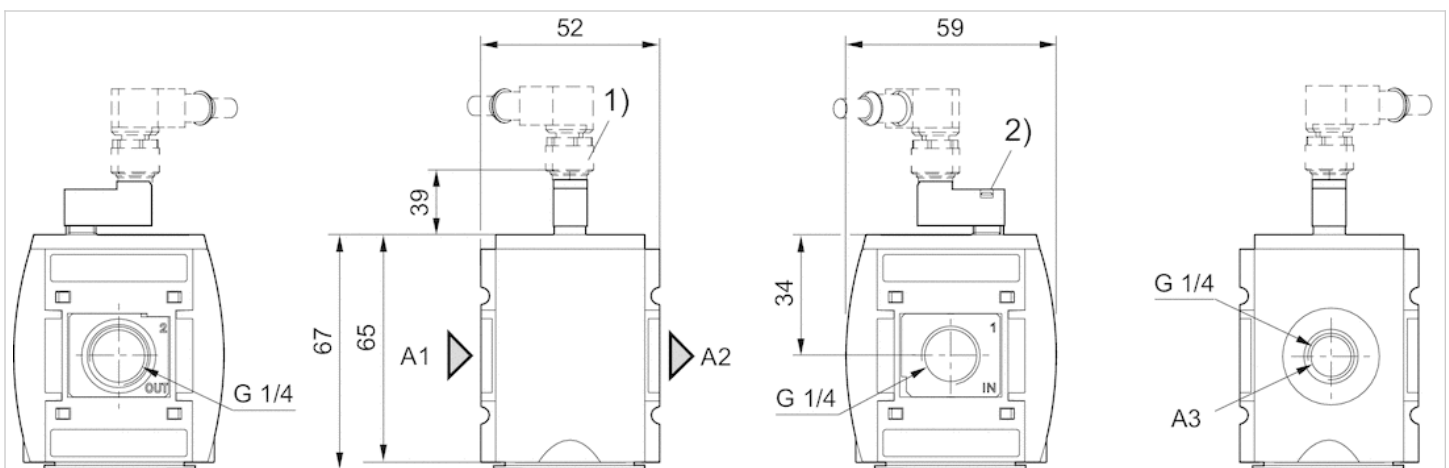

- A1 = input
- A2 = output
- A3 = ventilation port
- 1) plug M12
- 2) Manual override

Dimensions in mm, Fig. 8, 3/2-directional valve with pilot valve, push-in fitting M12x1

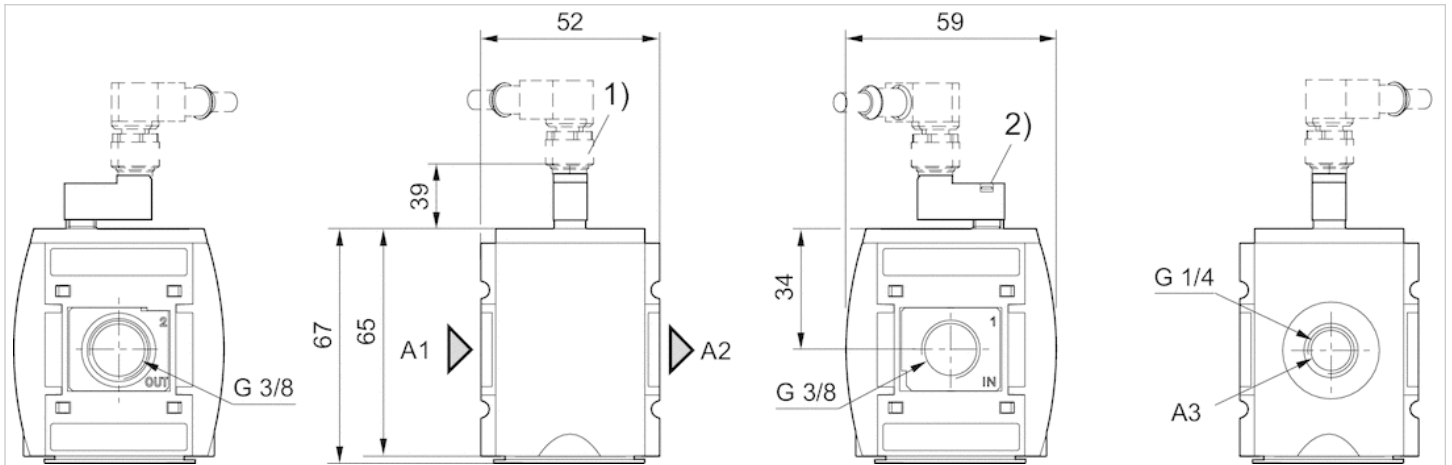

- A1 = input
- A2 = output
- A3 = ventilation port
- 1) plug M12
- 2) Manual override

Diagrams

Rear exhaust

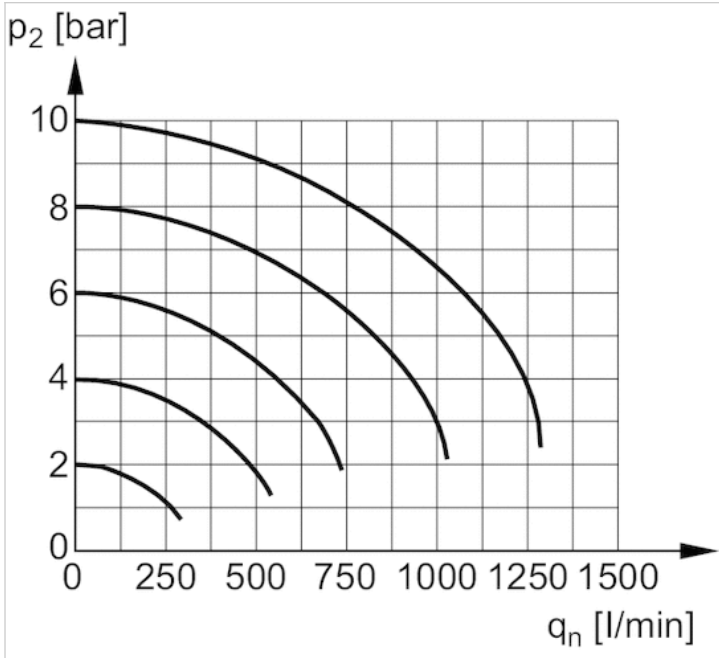

p_2 = secondary pressure
 q_n = nominal flow

Flow rate characteristic

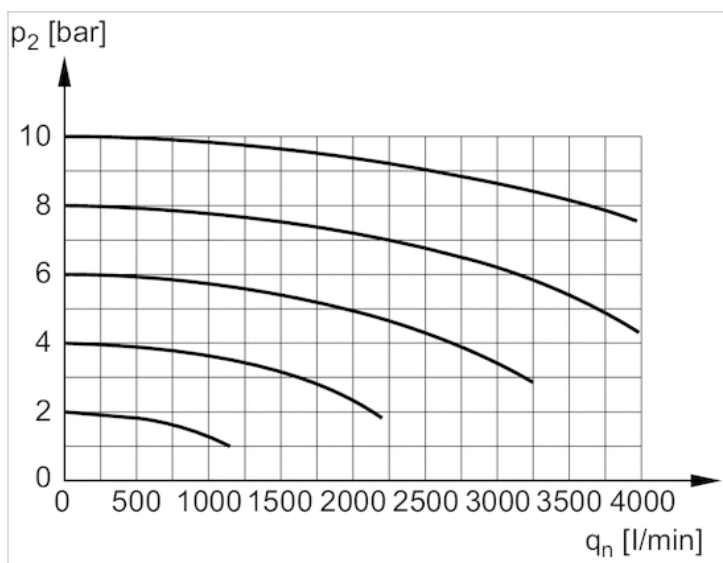

p_2 = secondary pressure

q_n = nominal flow

Pin assignments

Pin assignment M12x1

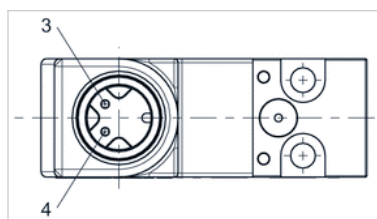

3: +/-

4: +/-

3/2-directional valve, pneumatically operated, Series AS2-SOV

- Compressed air connection G 1/4 G 3/8
- Pipe connection
- suitable for ATEX



Version

Sealing principle

Certificates

Working pressure min./max.

Control pressure min./max.

Ambient temperature min./max.

Medium temperature min./max.

Medium

Weight

Poppet valve, Can be assembled into blocks

Soft sealing

suitable for ATEX

0 ... 16 bar

2.5 ... 16 bar

-10 ... 50 °C

-10 ... 50 °C

Compressed air Neutral gases

0.219 kg

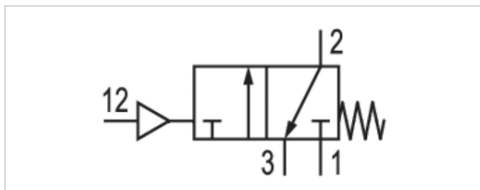

Technical data

Part No.	Port	Pilot connection	Exhaust	Flow	Flow	Flow	Fig.
				Qn	Qn 1→2	Qn 2→3	
R412006262	G 1/4	G 1/8	G 1/4	2000 l/min	2000 l/min	380 l/min	Fig. 1
R412006263	G 3/8	G 1/8	G 1/4	2000 l/min	2000 l/min	380 l/min	Fig. 2

Nominal flow Qn with secondary pressure p2 = 6 bar at Δp = 1 bar

Suitable for use in Ex zones 1, 2, 21, 22.

Technical information

The pressure dew point must be at least 15 °C under ambient and medium temperature and may not exceed 3 °C .
A short silencer is required for wall mounting (see accessories e.g. R412004817).

Technical information

Material	
Housing	Polyamide
Front plate	Acrylonitrile butadiene styrene
Seals	Acrylonitrile butadiene rubber
Threaded bushing	Die cast zinc

Dimensions

Dimensions in mm, Fig. 1

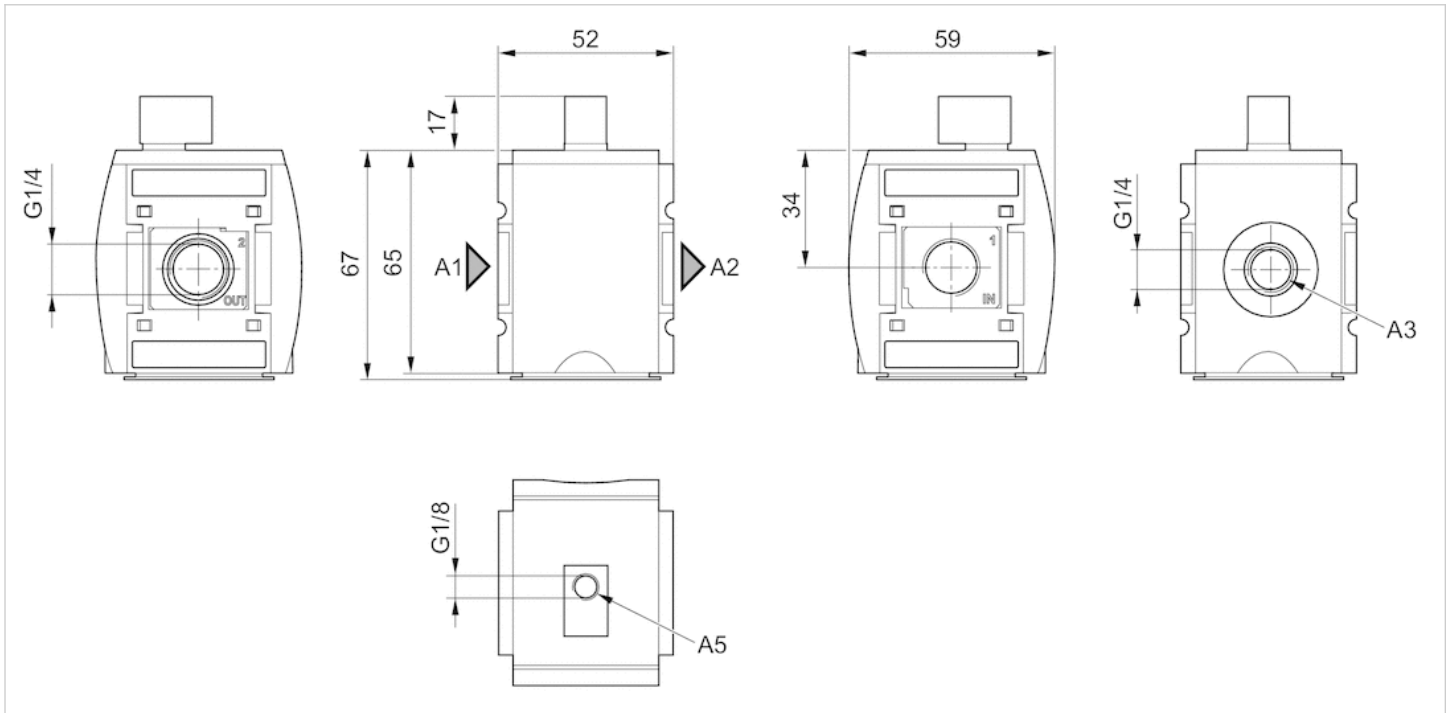

- A1 = input
- A2 = output
- A3 = ventilation port
- A5 = control pressure connection

Dimensions in mm, Fig. 2

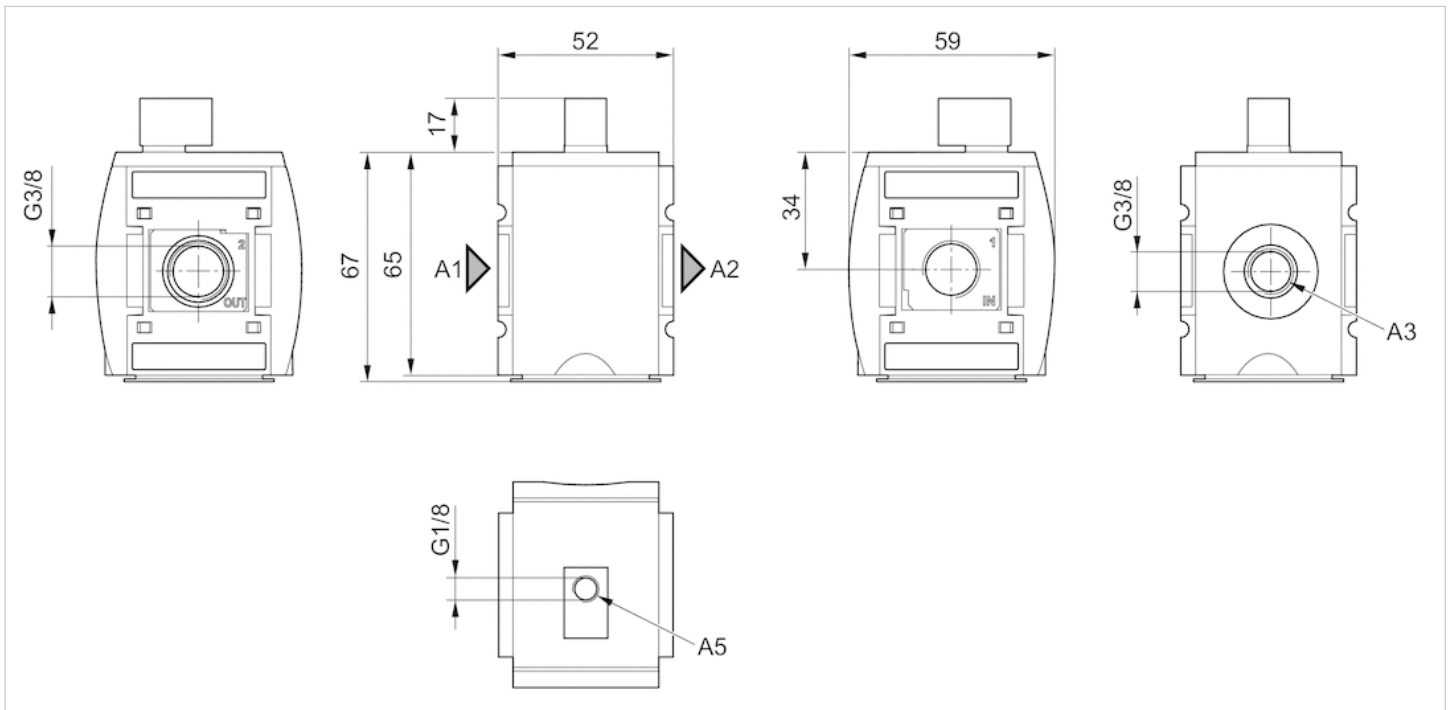

- A1 = input
- A2 = output
- A3 = ventilation port

A5 = control pressure connection

Diagrams

Flow rate characteristic

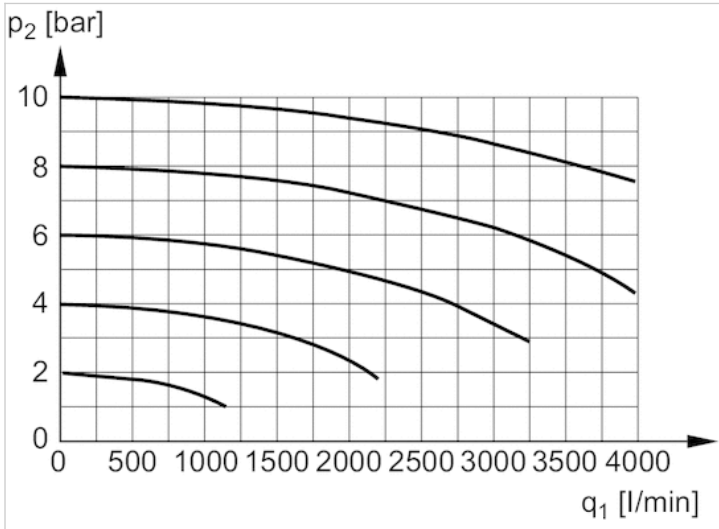

p₂ = secondary pressure
q_n = nominal flow

Rear exhaust

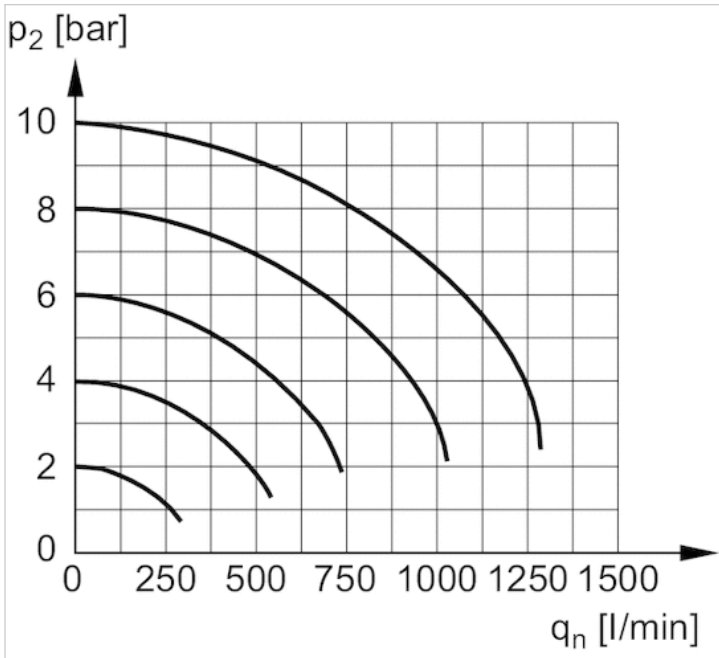

p₂ = secondary pressure
q_n = nominal flow

control pressure characteristic

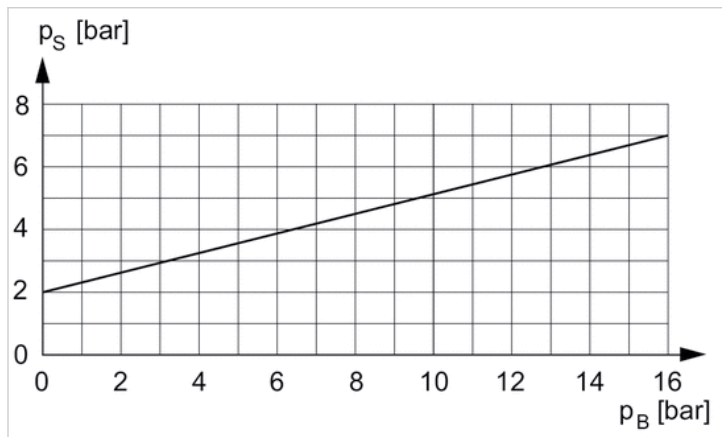

minimum pilot pressure depending on working pressure

PS = control pressure

PB= Working pressure

Accessories overview

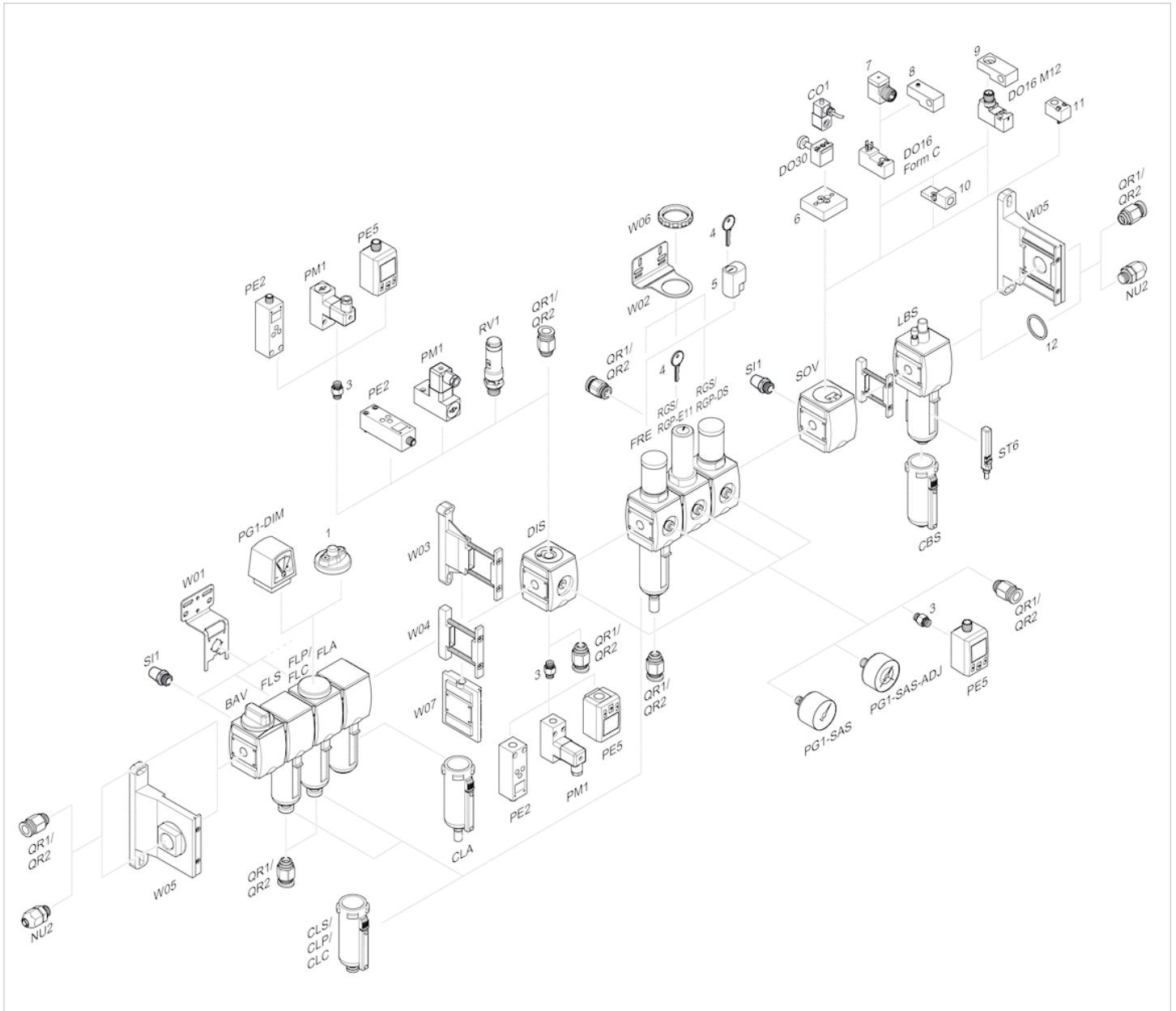

- 1 = contamination display
- 3 = Double nipple
- 4 = Key for E11 locking
- 5 = mortise lock
- 6 = Transition plate DO30
- 7 = Adapter, Series CON-VP
- 8 = Mounting aid DO16, form C
- 9 = Mounting aid DO16, M12
- 10 = Adapter for external pilot air
- 11 = Adapter pneumatic operation
- 12 = Sealing ring

3/2-shut-off valve, mechanically operated, Series AS2-BAV

- Qn 1►2 = 2000 l/min
- Qn 2►3 = 380 l/min
- Compressed air connection output G 1/4 G 3/8
- suitable for ATEX



Version	Poppet valve
Activation	Mechanical
Lock type	lockable
Actuating element	rotary switch
Sealing principle	Soft sealing
Certificates	suitable for ATEX
Working pressure min./max.	0 ... 16 bar
Ambient temperature min./max.	-10 ... 50 °C
Medium temperature min./max.	-10 ... 50 °C
Medium	Compressed air Neutral gases
Max. particle size	25 µm
Weight	0.206 kg

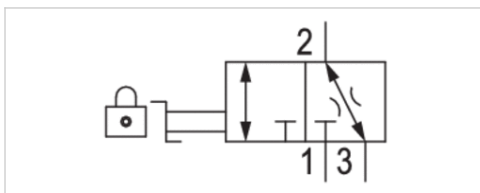

Technical data

Part No.	Compressed air connection type	Compressed air connection Input	Compressed air connection Output
R412006260	Internal thread	G 1/4	G 1/4
R412006256	Internal thread	G 1/4	G 1/4
R412006261	Internal thread	G 3/8	G 3/8
R412006257	Internal thread	G 3/8	G 3/8

Part No.	Compressed air connection Exhaust	Flow		Lock type	Locking base
		Qn 1 ► 2	Qn 2 ► 3		
R412006260	G 1/4	2000 l/min	380 l/min	for padlocks	Polyoxymethylene
R412006256	G 1/4	2000 l/min	380 l/min	for padlocks	Steel galvanized
R412006261	G 1/4	2000 l/min	380 l/min	for padlocks	Polyoxymethylene
R412006257	G 1/4	2000 l/min	380 l/min	for padlocks	Steel galvanized

Part No.	Fig.
R412006260	Fig. 1
R412006256	Fig. 1
R412006261	Fig. 2
R412006257	Fig. 2

Nominal flow Qn with secondary pressure p2 = 6 bar at Δp = 1 bar

Suitable for use in Ex zones 1, 2, 21, 22.

Technical information

The pressure dew point must be at least 15 °C under ambient and medium temperature and may not exceed 3 °C .
A short silencer is required for wall mounting (see accessories e.g. R412004817).
Suitable for use in Ex zones 1, 2, 21, 22.

Technical information

Material	
Housing	Polyamide
Front plate	Acrylonitrile butadiene styrene
Seals	Acrylonitrile butadiene rubber
Threaded bushing	Die cast zinc
Actuating element	Polyoxymethylene
Locking base	Polyoxymethylene Steel, galvanized

Dimensions

Dimensions in mm, Fig. 1

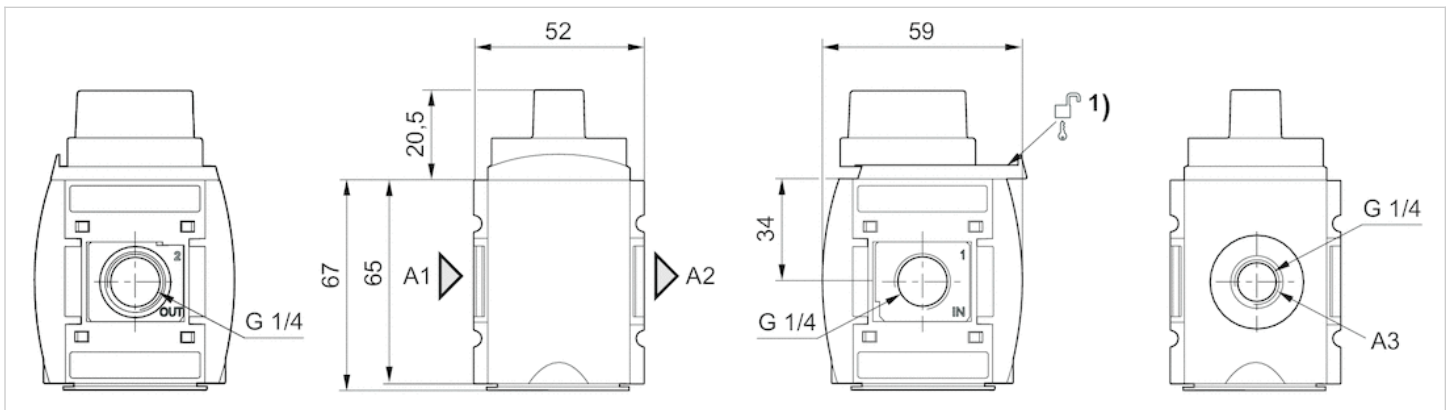

A1 = input

A2 = output

A3 = ventilation port

1) Mounting option for padlocks, max. shackle Ø 8

Dimensions in mm, Fig. 2

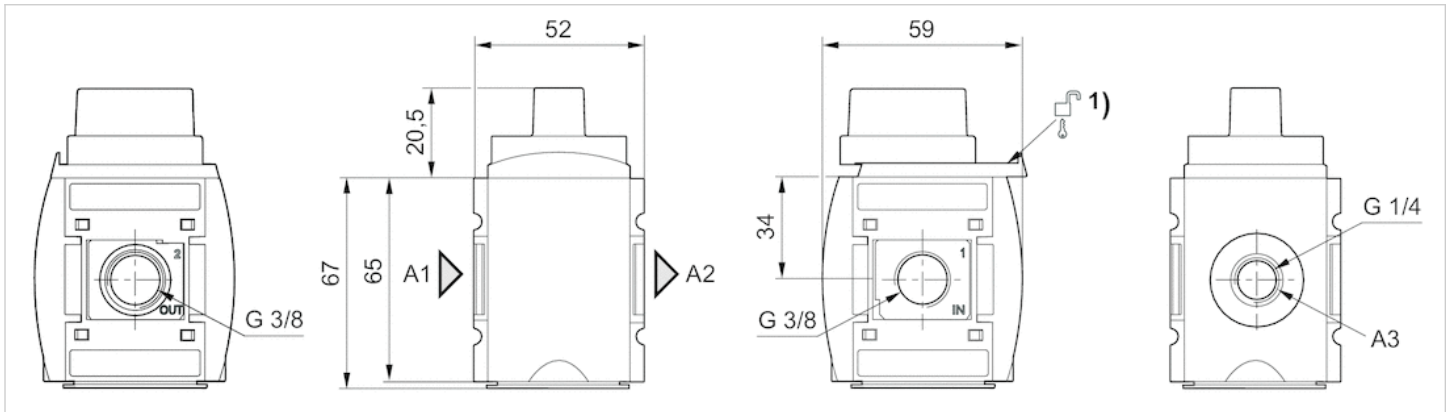

- A1 = input
- A2 = output
- A3 = ventilation port
- 1) Mounting option for padlocks, max. shackle Ø 8

Diagrams

Flow rate characteristic

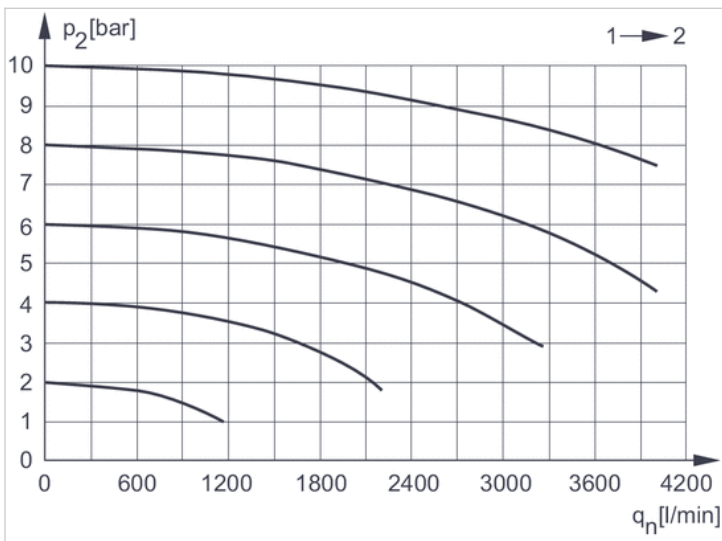

- p_2 = secondary pressure
- q_n = nominal flow

Rear exhaust

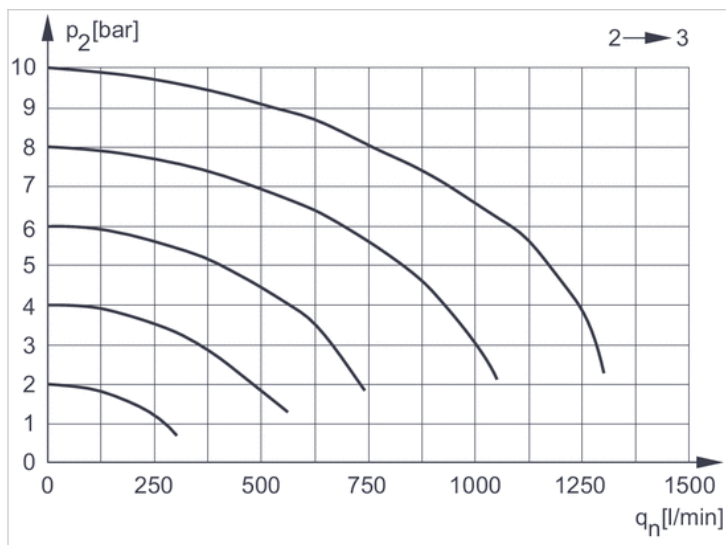

p₂ = secondary pressure
q_n = nominal flow

Accessories overview

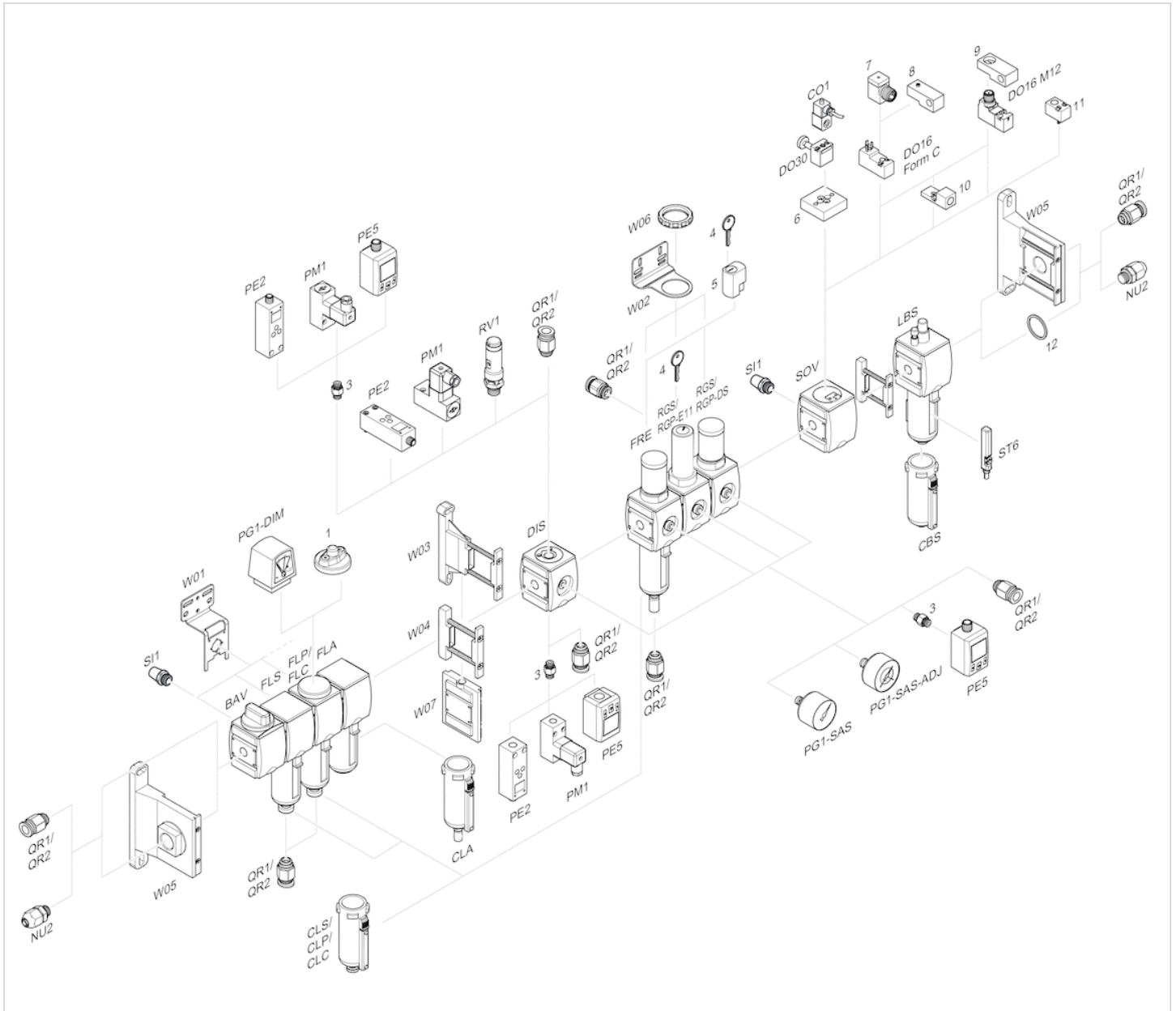

- 1 = contamination display
- 3 = Double nipple
- 4 = Key for E11 locking
- 5 = mortise lock
- 6 = Transition plate DO30
- 7 = Adapter, Series CON-VP
- 8 = Mounting aid DO16, form C
- 9 = Mounting aid DO16, M12
- 10 = Adapter for external pilot air
- 11 = Adapter pneumatic operation
- 12 = Sealing ring

3/2 directional safety valve, Series SV03-AS2

- Safe air supply and exhaust valve with soft-start function
- 3/2
- Compressed air connection output : Ø 13
- double solenoid
- With spring return
- Pilot : External Internal

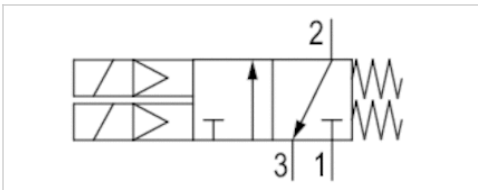

Activation	Electrically
Pilot	External Internal
Sealing principle	Soft sealing
Standards	ISO 13849-1, category 4, performance level: e (possible)
Working pressure min./max. Internal	3 ... 10 bar
Working pressure min./max. External	0 ... 10 bar
Control pressure min./max.	3 ... 10 bar
Ambient temperature min./max.	4 ... 50 °C
Medium temperature min./max.	4 ... 50 °C
Medium	Compressed air
Max. particle size	5 µm
Oil content of compressed air	0 ... 5 mg/m ³
Nominal flow 1 ► 2	1050 l/min
Nominal flow 2 ► 3	2650 l/min
Connector standard	EN 175301-803, form C
Protection class with connection	IP65
Duty cycle	100 %
Typ. switch-on time	30 ms
Typ. switch-off time	70 ms
Version sensor	PNP
Sensor Electrical interface	Plug, M8, 3-pin
Weight	1.9 kg
Comment	Control pressure: Equal or greater than operating pressure.

Technical data

Part No.	Compressed air connection	
	Input	Output
R412027220	Ø 13	Ø 13

Part No.	Compressed air connection	Operational voltage	Voltage tolerance
	Exhaust		
R412027220	G 1/2	DC 24 V	DC -10% / +10%

Part No.	Power consumption
	DC
R412027220	1.5 W

Technical information

The min. control pressure must be adhered to, since otherwise faulty switching and valve failure may result!
 The pressure dew point must be at least 15 °C under ambient and medium temperature and may not exceed 3 °C .
 The oil content of compressed air must remain constant during the life cycle.
 Use only the approved oils from AVENTICS. Further information can be found in the “Technical information” document (available in the MediaCentre).

Directional safety valve series SV is delivered and configured for internal control pressure. It easily can be converted to external control pressure. Please refer to operating instructions. Control pressure must be equal to or greater than inlet pressure.

Technical information

Material	
Housing	Die-cast aluminum
Seals	Acrylonitrile butadiene rubber

Dimensions

Dimensions

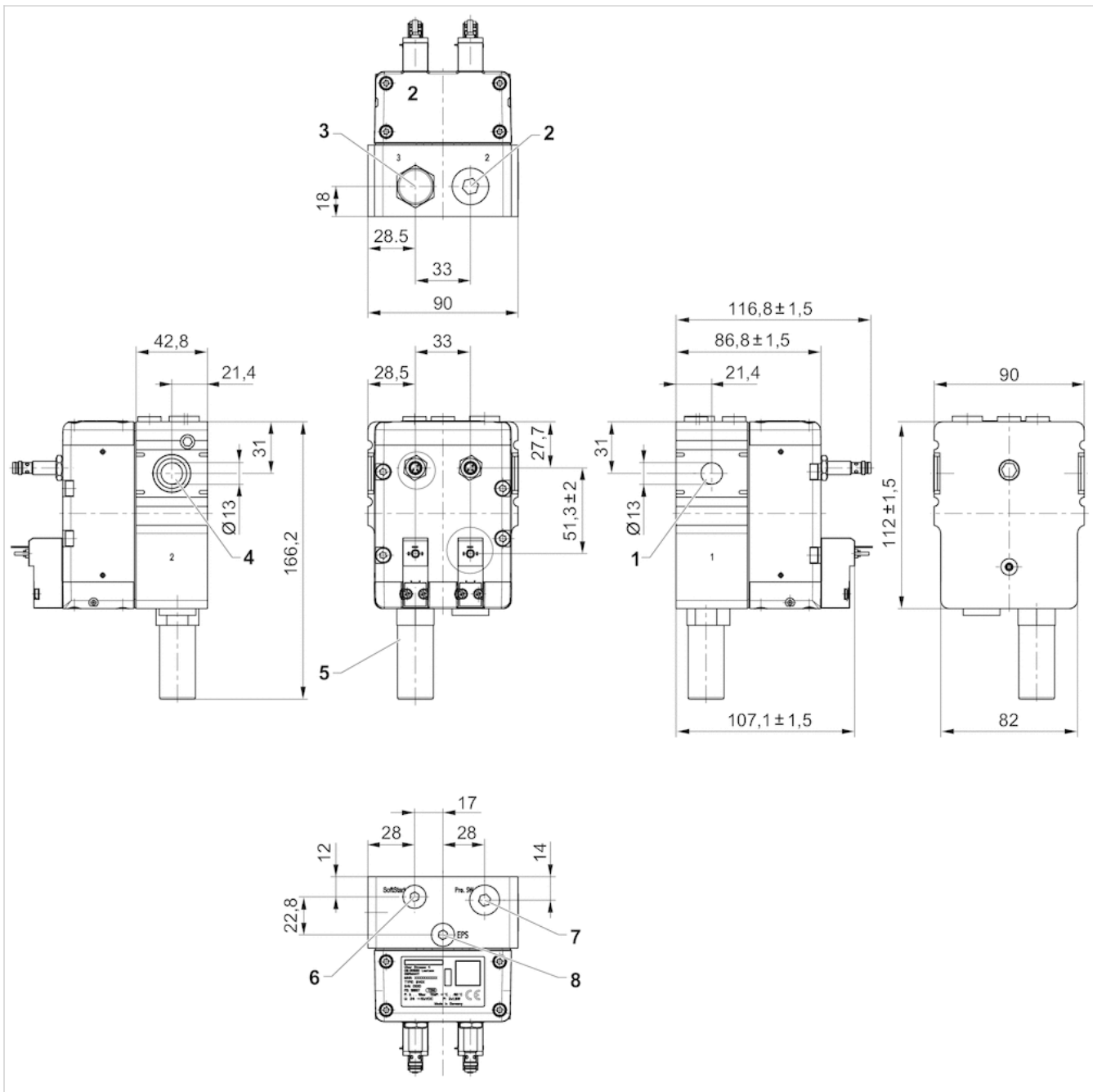

- 1) Port 1 (Input)
- 2) Port 2 (Output)
- 3) Port 3 (Exhaust)
- 4) Flow outlet G 3/8
- 5) Silencer
- 6) Connection for soft start with plug G1/8
- 7) Connection for pressure switch with plug G1/4
- 8) Connection for external pilot supply with plug G1/8

Diagrams

safe air supply and exhaust valve with soft-start function

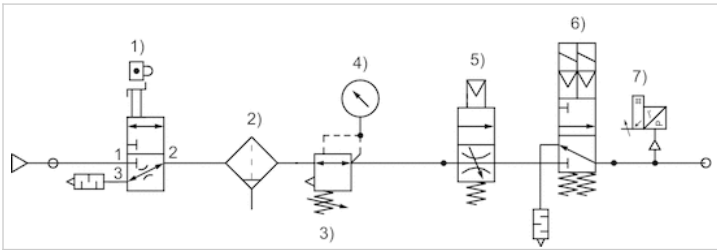

- 1) Lockout valve
- 2) Filter
- 3) Pressure regulator
- 4) Pressure gauge
- 5) Soft-start valve
- 6) Safety exhaust valve SV03-AS2
- 7) Pressure Switches

Pin assignments

Pin assignment M8x1 (3-pin)

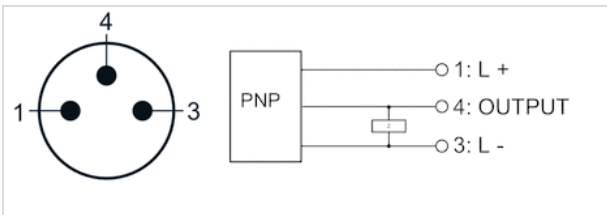

Valve plug connector form C

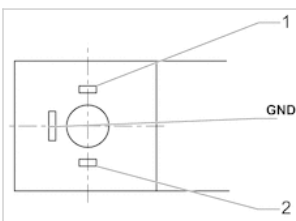

Distributor, Series AS2-DIS

- G 1/4 G 3/8
- Distributor 3x
- suitable for ATEX



Version	Can be assembled into blocks
Parts	Distributor
Mounting orientation	Any
Certificates	suitable for ATEX
Working pressure min./max.	0 ... 16 bar
Ambient temperature min./max.	-10 ... 50 °C
Medium temperature min./max.	-10 ... 50 °C
Medium	Compressed air Neutral gases
Weight	0.25 kg

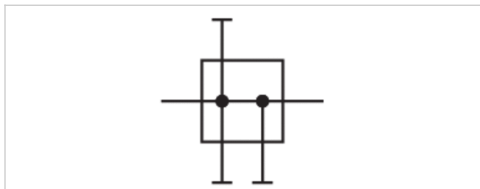

Technical data

Part No.	Port	Nominal flow	Nominal flow	Nominal flow	Nominal flow	Fig.
		Qn 1►2	Qn 1►3	Qn 1►4	Qn 1►5	
R412006250	G 1/4	2700 l/min	2000 l/min	900 l/min	2000 l/min	Fig. 1
R412006251	G 3/8	3600 l/min	2000 l/min	900 l/min	2000 l/min	Fig. 2

Nominal flow Qn with secondary pressure p2 = 6 bar at Δp = 1 bar

Suitable for use in Ex zones 1, 2, 21, 22.

Technical information

The pressure dew point must be at least 15 °C under ambient and medium temperature and may not exceed 3 °C .

Suitable for direct mounting of a PE2 and PM1 series pressure sensor (flange version).

Suitable for use in Ex zones 1, 2, 21, 22.

A change in the flow direction (from air supply on the left to air supply on the right) occurs by rotating installation by 180° about the vertical axis. Please see the operating instructions for further details.

Technical information

Material	
Housing	Polyamide
Front plate	Acrylonitrile butadiene styrene
Seals	Acrylonitrile butadiene rubber
Threaded bushing	Die cast zinc

Dimensions

Dimensions in mm, Fig. 1

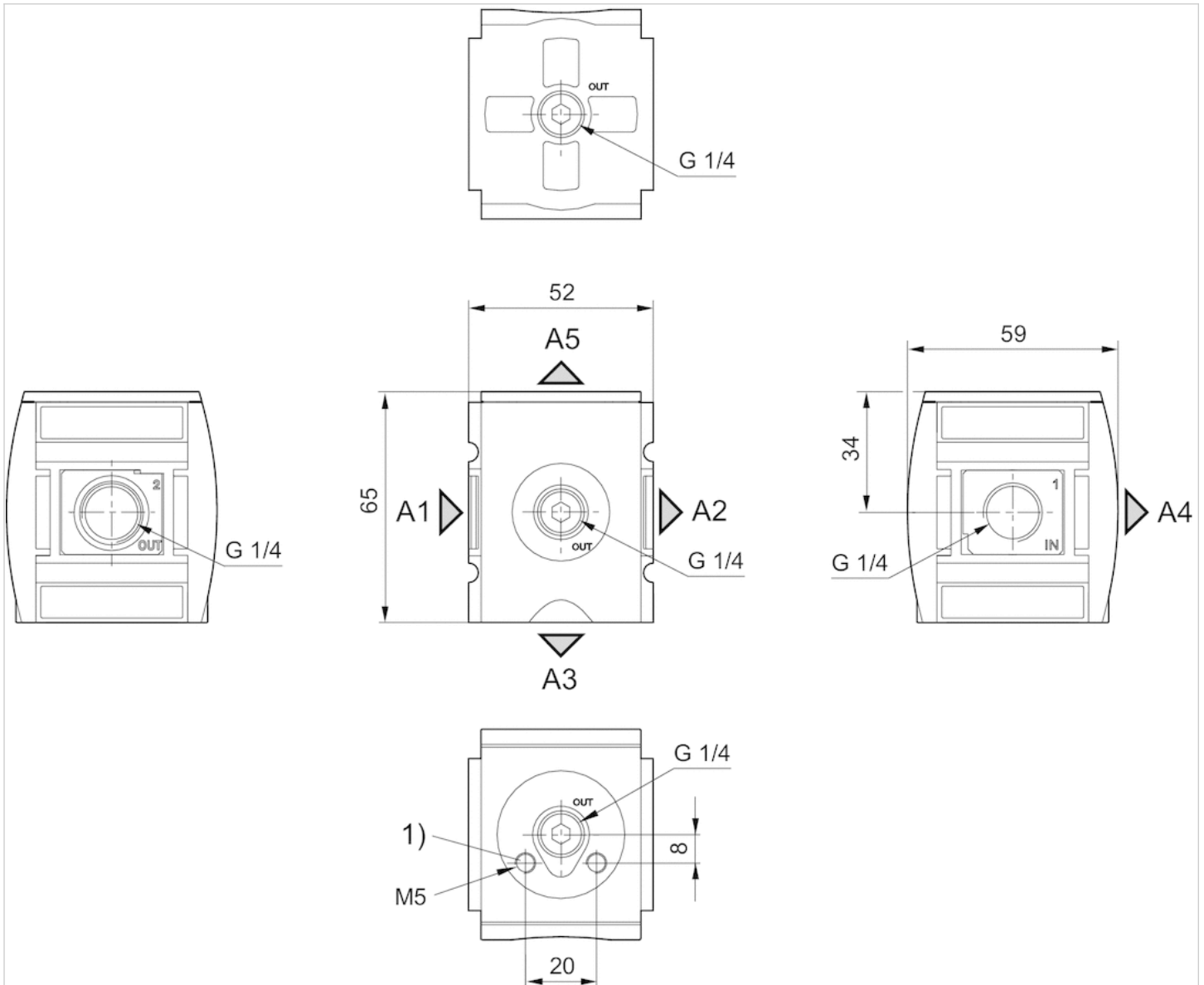

- A1 = input
- A2 = output
- A3 = output
- A4 = output
- A5 = output
- 1) Mounting thread for pressure sensor

Dimensions in mm, Fig. 2

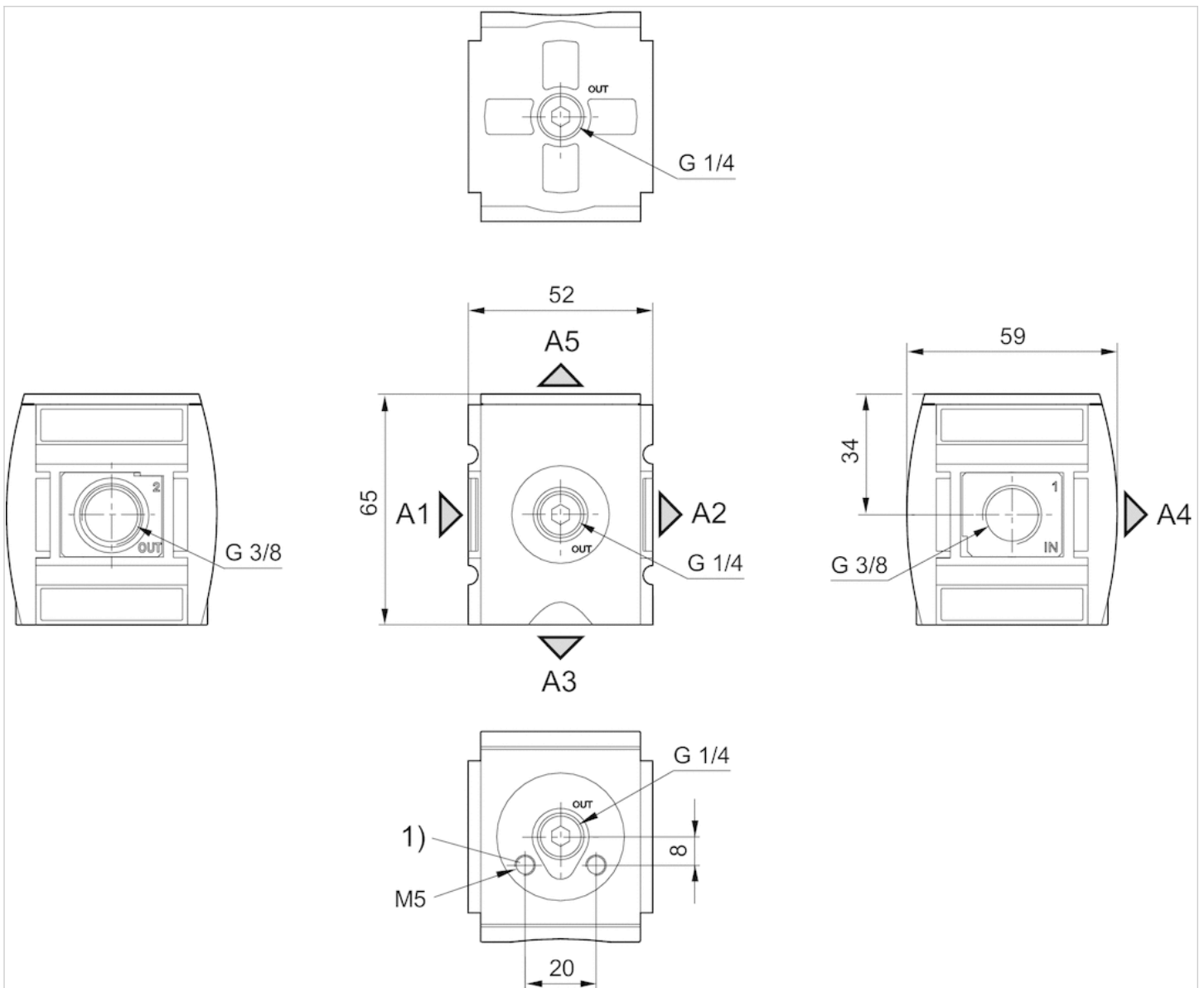

- A1 = input
- A2 = output
- A3 = output
- A4 = output
- A5 = output
- 1) Mounting thread for pressure sensor

Accessories overview

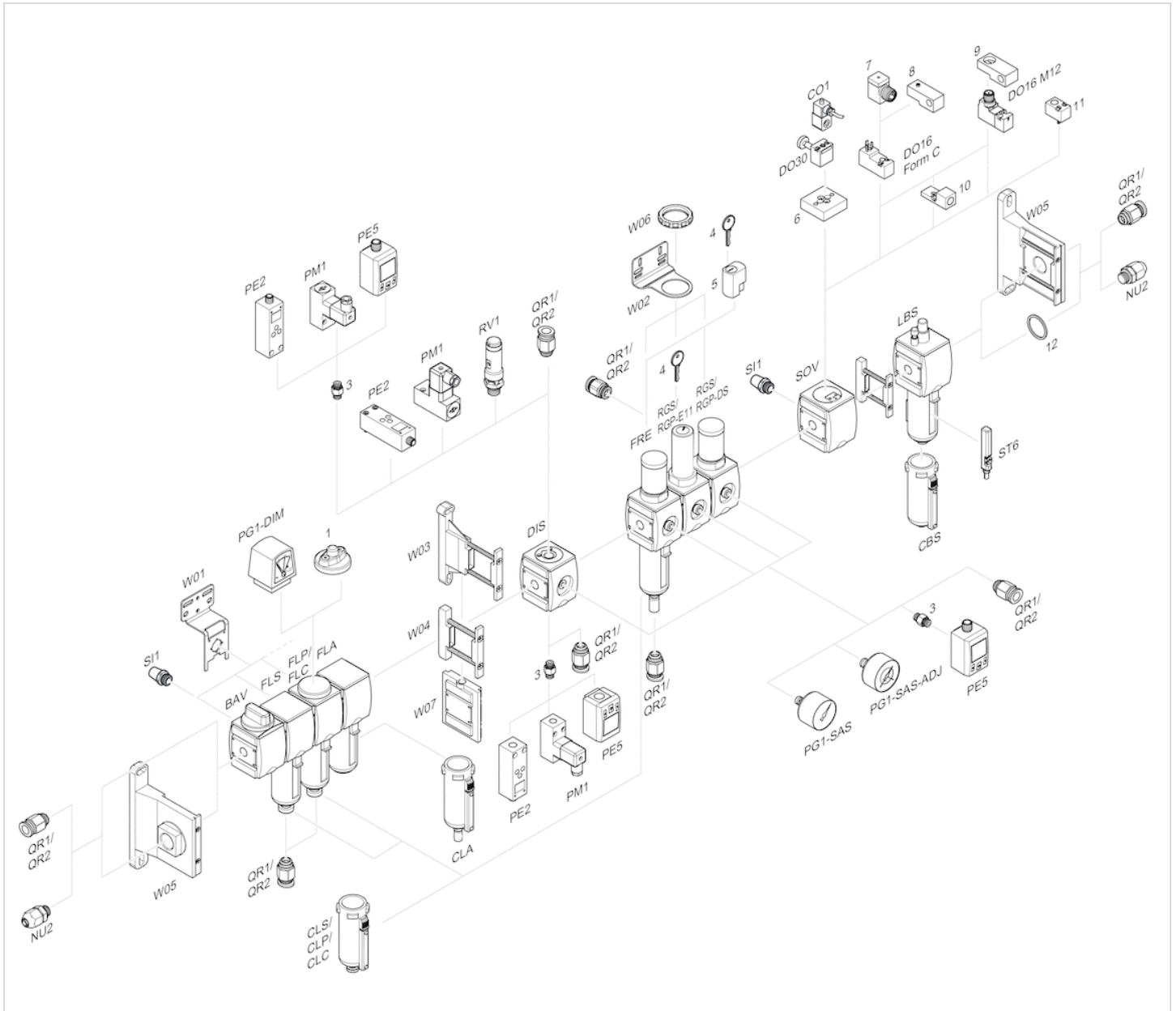

- 1 = contamination display
- 3 = Double nipple
- 4 = Key for E11 locking
- 5 = mortise lock
- 6 = Transition plate DO30
- 7 = Adapter, Series CON-VP
- 8 = Mounting aid DO16, form C
- 9 = Mounting aid DO16, M12
- 10 = Adapter for external pilot air
- 11 = Adapter pneumatic operation
- 12 = Sealing ring

Distributor, Series AS2-DIN

- G 1/4 G 3/8
- Distributor 1x
- Non-return valve
- suitable for ATEX



Version

Parts

Mounting orientation

Certificates

Working pressure min./max.

Ambient temperature min./max.

Medium temperature min./max.

Medium

Weight

Non-return valve, Can be assembled into blocks

Distributor

Any

suitable for ATEX

0.4 ... 16 bar

-10 ... 50 °C

-10 ... 50 °C

Compressed air Neutral gases

0.25 kg

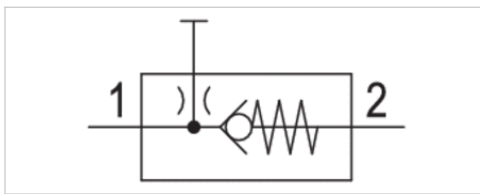

Technical data

Part No.	Port	Nominal flow		Fig.
		Qn 1►2	Qn 1►6	
R412006254	G 1/4	1250 l/min	700 l/min	Fig. 1
R412006255	G 3/8	1250 l/min	700 l/min	Fig. 2

Nominal flow Qn with secondary pressure p2 = 6 bar at Δp = 1 bar

Suitable for use in Ex zones 1, 2, 21, 22.

Technical information

The pressure dew point must be at least 15 °C under ambient and medium temperature and may not exceed 3 °C .

Suitable for direct mounting of a PE2 and PM1 series pressure sensor (flange version).

Suitable for use in Ex zones 1, 2, 21, 22.

A change in the flow direction (from air supply on the left to air supply on the right) occurs by rotating installation by 180° about the vertical axis. Please see the operating instructions for further details.

Technical information

Material	
Housing	Polyamide
Front plate	Acrylonitrile butadiene styrene
Seals	Acrylonitrile butadiene rubber

Material	
Threaded bushing	Die cast zinc

Dimensions

usage

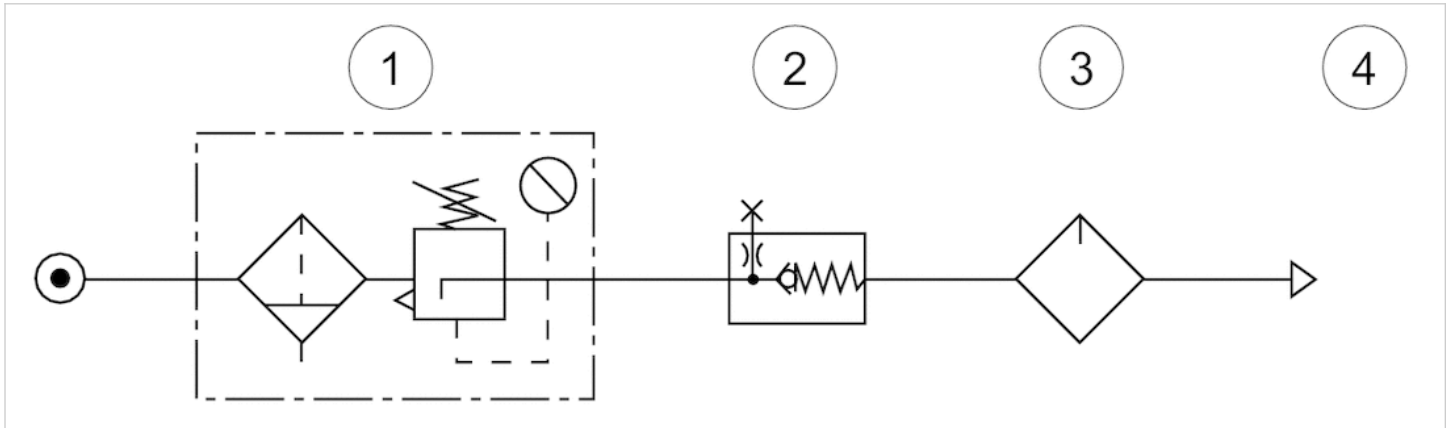

- 1) Filter pressure regulator
- 2) Non-return valve
- 3) Lubricator
- 4) Compressed air

Dimensions in mm, Fig. 1

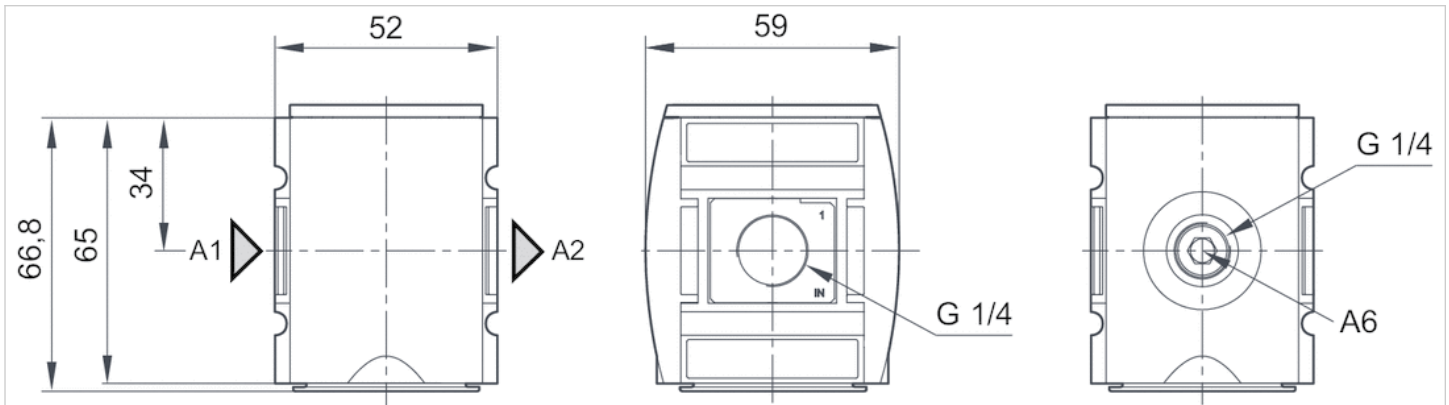

- A1 = input
- A2 = output
- A6 = output

Dimensions in mm, Fig. 2

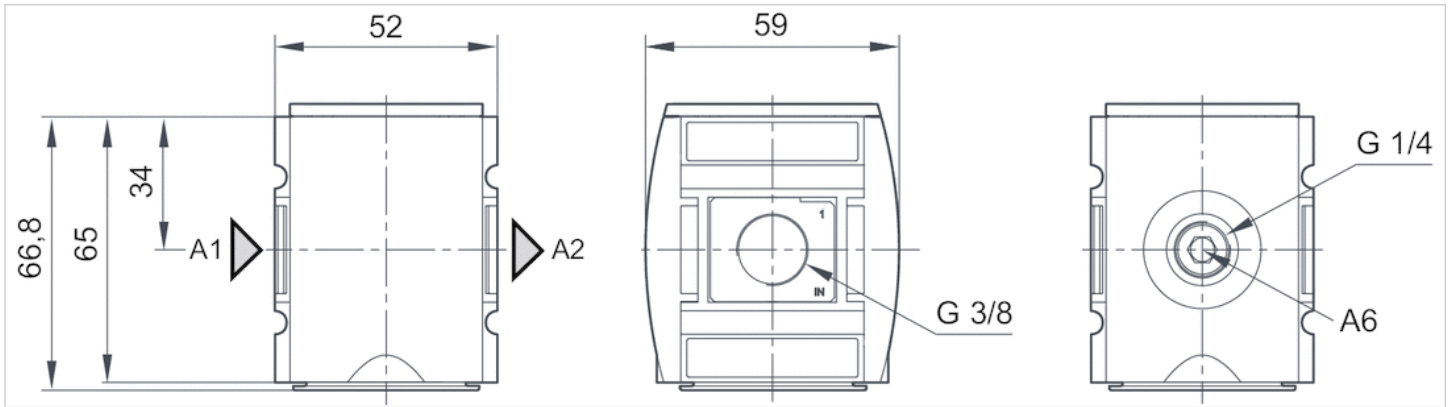

A1 = input
 A2 = output
 A6 = output

Diagrams

Flow rate characteristic

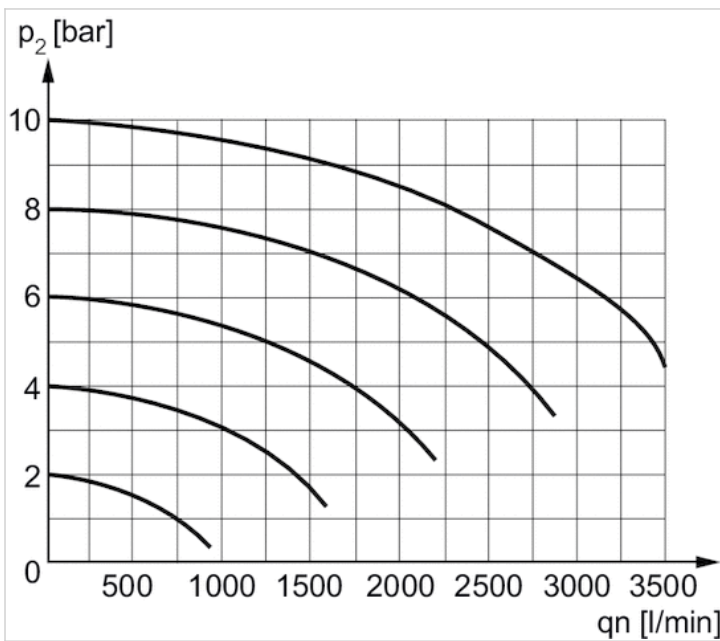

Nominal flow 1 ► 2
 p2 = secondary pressure
 qn = nominal flow

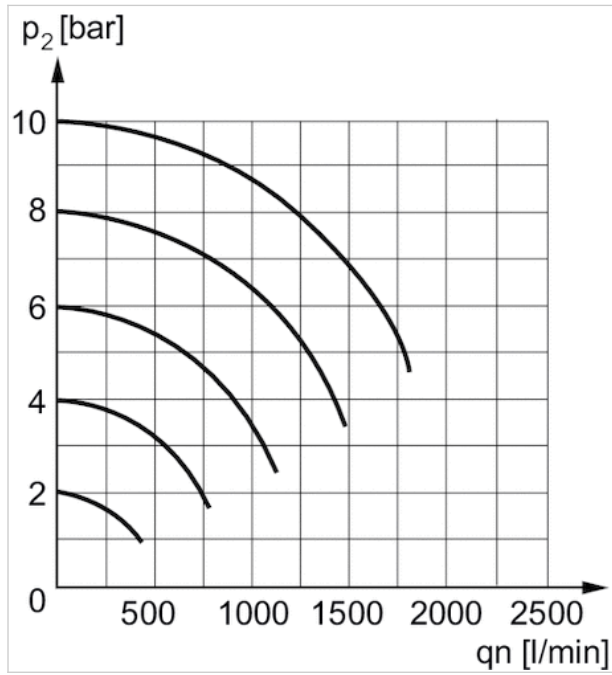

Nominal flow 1 ▶ 3
 p2 = secondary pressure
 qn = nominal flow

Accessories overview

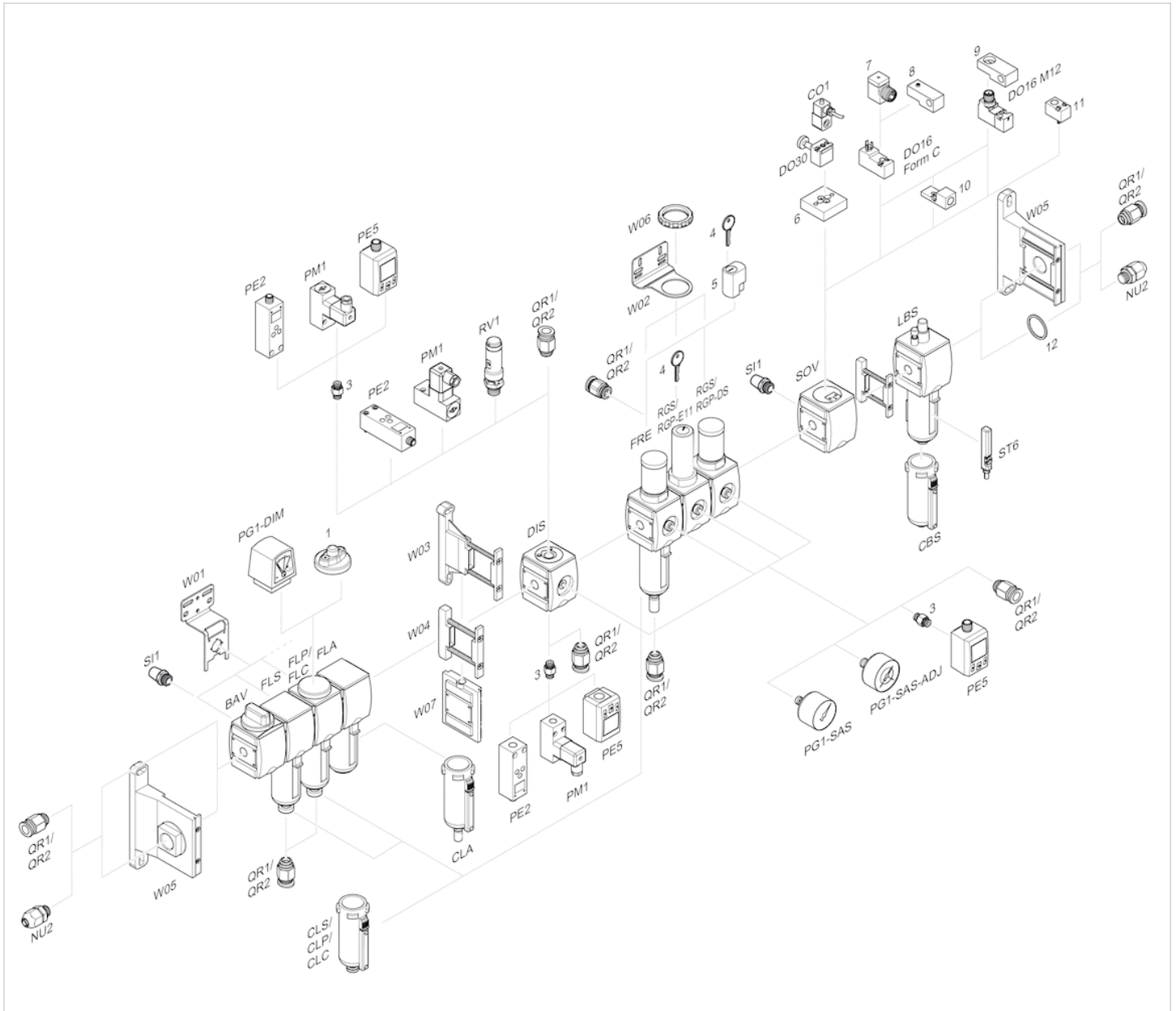

- 1 = contamination display
- 3 = Double nipple
- 4 = Key for E11 locking
- 5 = mortise lock
- 6 = Transition plate DO30
- 7 = Adapter, Series CON-VP
- 8 = Mounting aid DO16, form C
- 9 = Mounting aid DO16, M12
- 10 = Adapter for external pilot air
- 11 = Adapter pneumatic operation
- 12 = Sealing ring

Distributor, Series AS2-DIC

- G 3/8
- Distributor 3x
- Center infeed
- suitable for ATEX



Version

Parts

Mounting orientation

Certificates

Working pressure min./max.

Ambient temperature min./max.

Medium temperature min./max.

Medium

Weight

Center infeed, Can be assembled into blocks

Distributor

Any

suitable for ATEX

0 ... 16 bar

-10 ... 50 °C

-10 ... 50 °C

Compressed air Neutral gases

0.648 kg

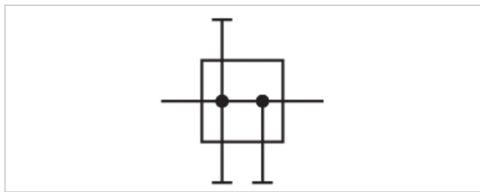

Technical data

Part No.	Port	Nominal flow	Nominal flow	Nominal flow	Nominal flow
		Qn 1►2	Qn 1►3	Qn 1►4	Qn 1►5
R412006249	G 3/8	2700 l/min	2000 l/min	900 l/min	2000 l/min

Nominal flow Qn with secondary pressure p2 = 6 bar at Δp = 1 bar

Suitable for use in Ex zones 1, 2, 21, 22.

Technical information

The pressure dew point must be at least 15 °C under ambient and medium temperature and may not exceed 3 °C .

Suitable for direct mounting of a PE2 and PM1 series pressure sensor (flange version).

Suitable for use in Ex zones 1, 2, 21, 22.

A change in the flow direction (from air supply on the left to air supply on the right) occurs by rotating installation by 180° about the vertical axis. Please see the operating instructions for further details.

Technical information

Material	
Housing	Polyamide
Front plate	Acrylonitrile butadiene styrene
Seals	Acrylonitrile butadiene rubber
Threaded bushing	Die cast zinc

Dimensions

Dimensions in mm

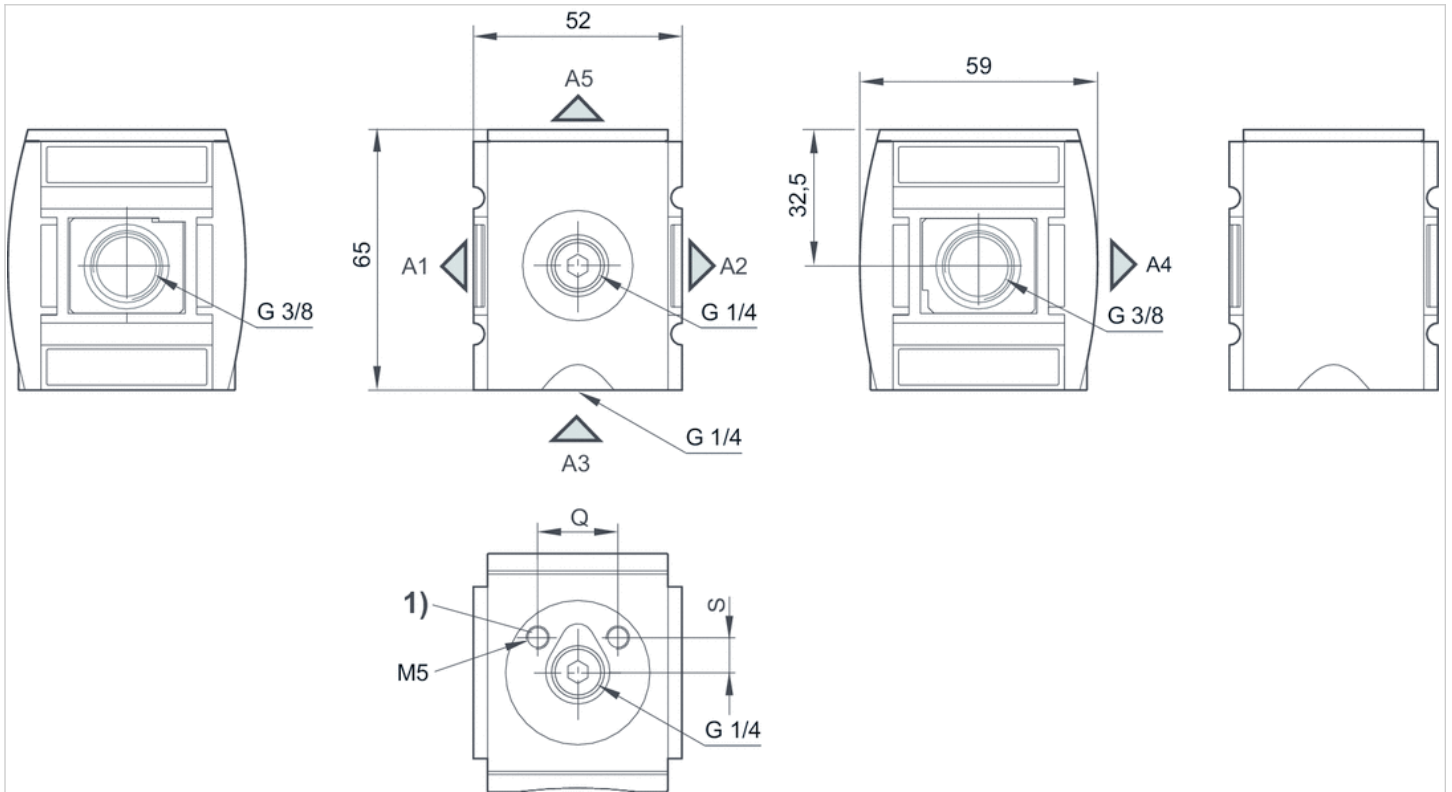

- A1 = output
- A2 = output
- A3 = input/output
- A4 = output
- A5 = input/output
- 1) Mounting thread for pressure sensor

Accessories overview

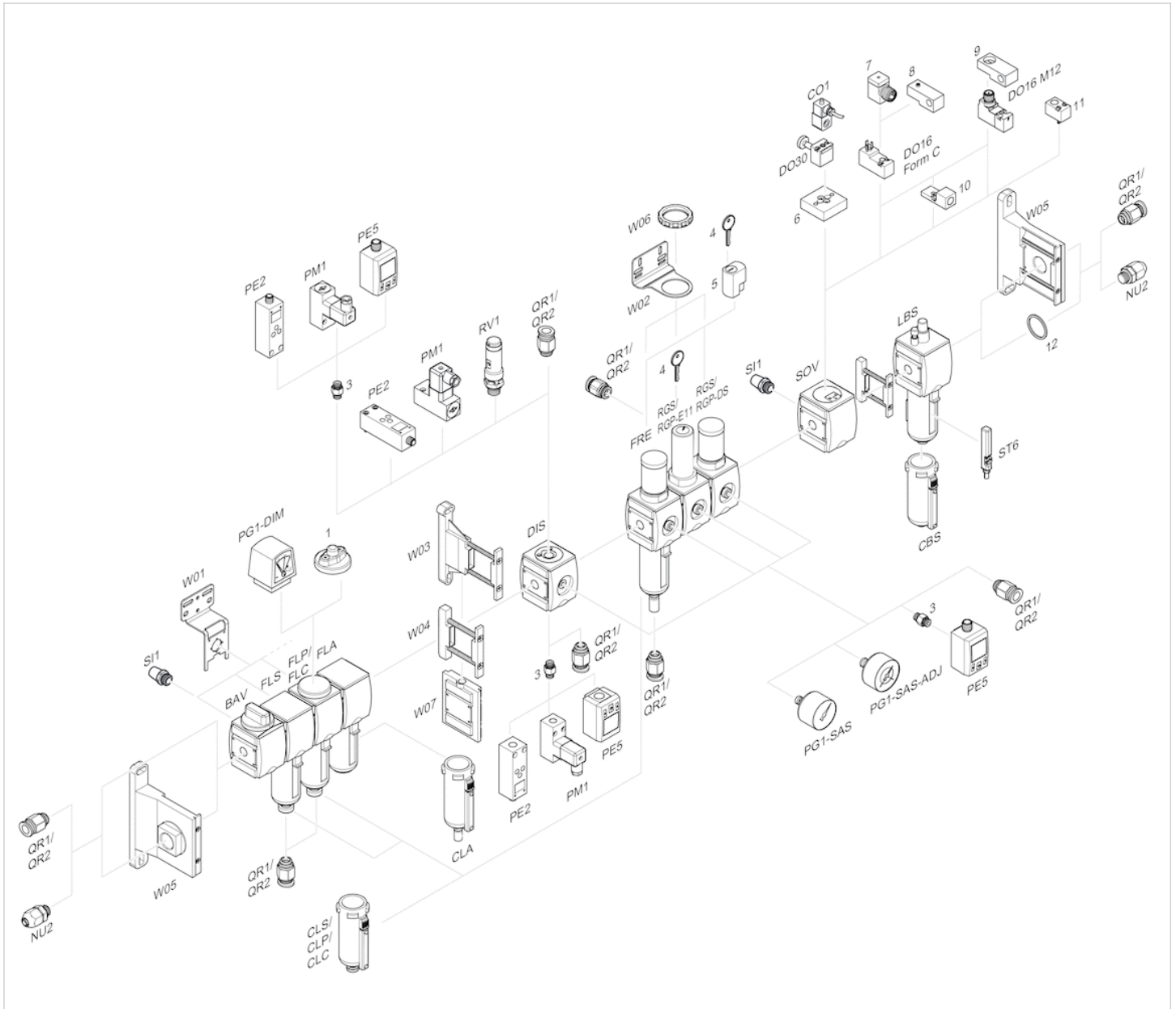

- 1 = contamination display
- 3 = Double nipple
- 4 = Key for E11 locking
- 5 = mortise lock
- 6 = Transition plate DO30
- 7 = Adapter, Series CON-VP
- 8 = Mounting aid DO16, form C
- 9 = Mounting aid DO16, M12
- 10 = Adapter for external pilot air
- 11 = Adapter pneumatic operation
- 12 = Sealing ring

Reservoir, Series AS2-CLS/ -CLP/ -CLC

- for filters, pre-filters and microfilters
- Material Polycarbonate Die cast zinc
- suitable for ATEX



Version	Reservoir
Certificates	suitable for ATEX
Working pressure min./max.	16 bar
Ambient temperature min./max.	-10 ... 50 °C
Medium temperature min./max.	-10 ... 50 °C
Medium	Compressed air
Filter reservoir volume	28 cm ³
Weight	See table below

Technical data

Part No.	Condensate drain	Reservoir
R412006338	semi-automatic, open without pressure	Polycarbonate
R412006339	fully automatic, open without pressure	Polycarbonate
R412006340	fully automatic, closed without pressure	Polycarbonate
R412006344	semi-automatic, open without pressure	Die cast zinc, with window
R412006345	fully automatic, open without pressure	Die cast zinc, with window
R412006346	fully automatic, closed without pressure	Die cast zinc, with window

Part No.	Protective guard	Weight	Fig.
R412006338	Polyamide	0.077 kg	Fig. 1
R412006339	Polyamide	0.12 kg	Fig. 2
R412006340	Polyamide	0.12 kg	Fig. 2
R412006344	-	0.338 kg	Fig. 1
R412006345	-	0.39 kg	Fig. 2
R412006346	-	0.39 kg	Fig. 2

Suitable for use in Ex zones 1, 2, 21, 22.

Technical information

Material	
Reservoir	Polycarbonate Die cast zinc
Protective guard	Polyamide
Seal	Acrylonitrile butadiene rubber

Dimensions

Dimensions in mm, Fig. 1

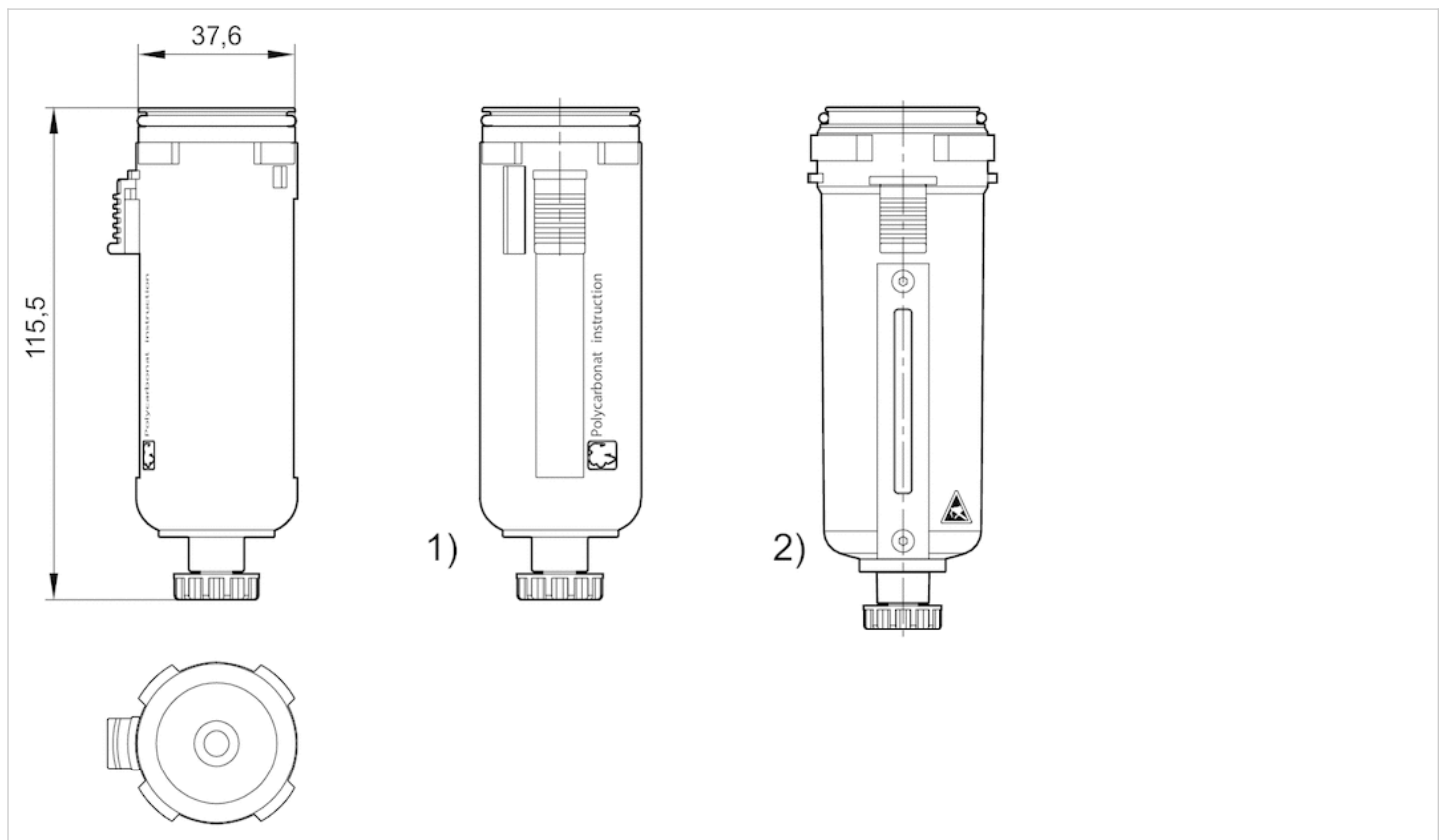

- 1) Plastic reservoir and protective guard with window
- 2) Metal reservoir with inspection glass

Dimensions in mm, Fig. 2

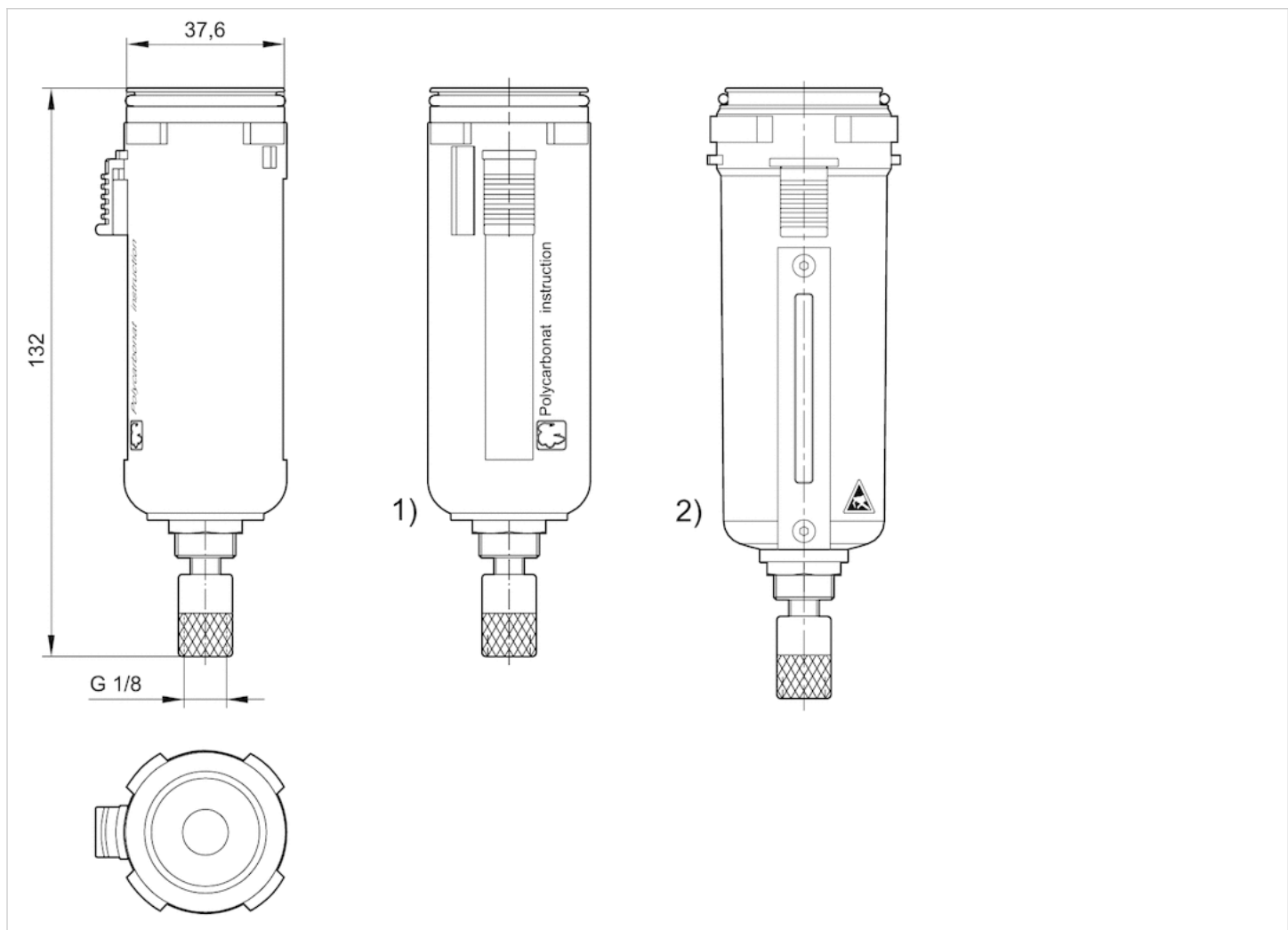

- 1) Plastic reservoir and protective guard with window
- 2) Metal reservoir with inspection glass

Reservoir, Series AS2-CLA

- for active carbon filter
- Material Polycarbonate Die cast zinc
- suitable for ATEX



Version	Reservoir
Certificates	suitable for ATEX
Working pressure min./max.	0 ... 16 bar
Ambient temperature min./max.	-10 ... 50 °C
Medium temperature min./max.	-10 ... 50 °C
Medium	Compressed air
Filter reservoir volume	28 cm ³
Weight	See table below

Technical data

Part No.	Reservoir	Protective guard	Weight
R412006347	Polycarbonate	Polyamide	0.77 kg
R412006349	Die cast zinc, with window	-	0.338 kg

Suitable for use in Ex zones 1, 2, 21, 22.

Technical information

Material	
Reservoir	Polycarbonate Die cast zinc
Protective guard	Polyamide
Seal	Acrylonitrile butadiene rubber

Dimensions

Dimensions in mm

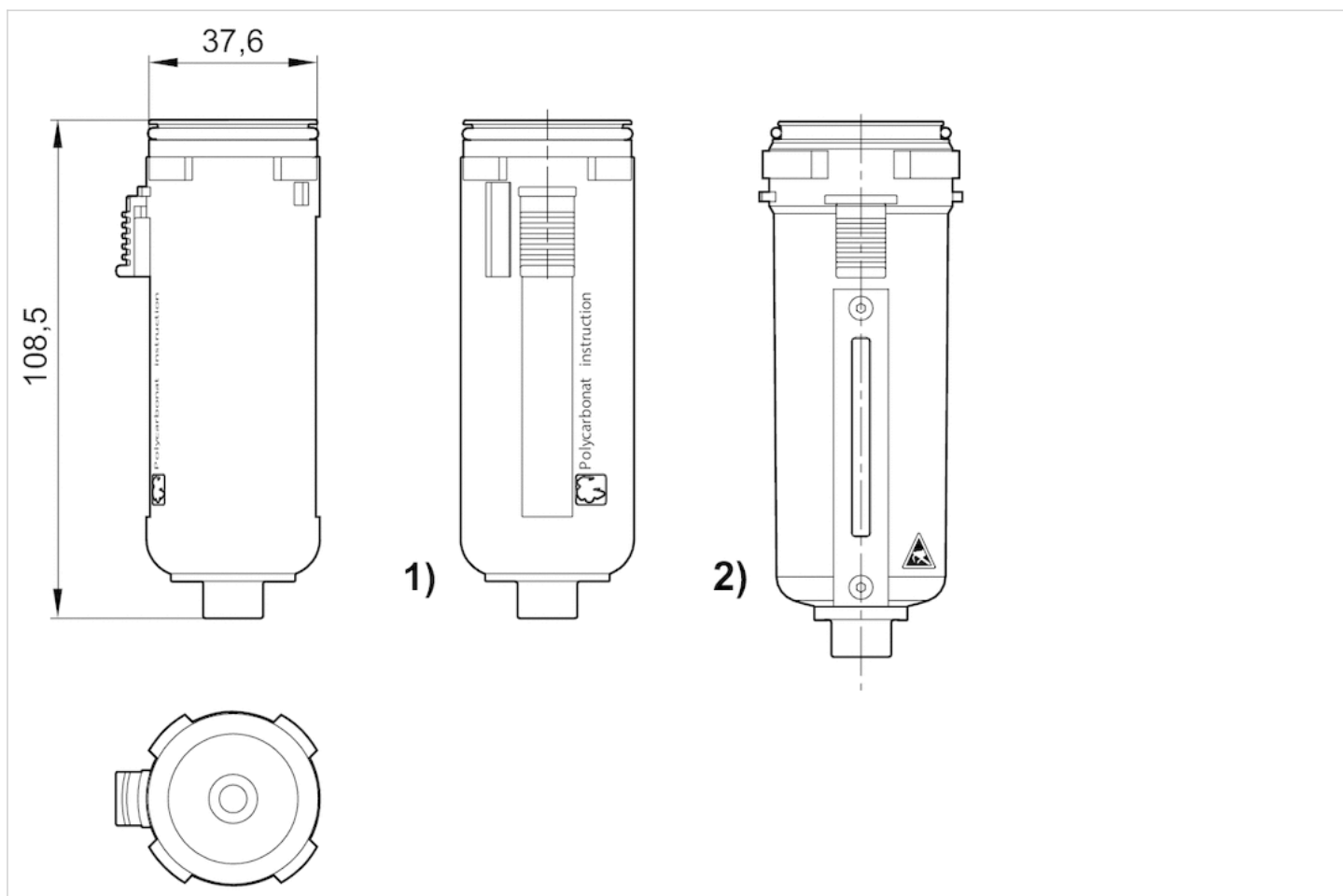

- 1) Plastic reservoir and protective guard with window
- 2) Metal reservoir with inspection glass

Reservoir, Series AS2-CBS

- for lubricator
- Material Polycarbonate Die cast zinc
- suitable for ATEX



Version	Reservoir
Certificates	suitable for ATEX
Working pressure min./max.	0 ... 16 bar
Ambient temperature min./max.	-10 ... 50 °C
Medium temperature min./max.	-10 ... 50 °C
Medium	Compressed air Oil
Lubricator reservoir volume	40 cm ³
Weight	See table below

Technical data

Part No.	Electrical level indicator	Reservoir	Protective guard	Weight
R412006352	-	Polycarbonate	Polyamide	0.77 kg
R412006358	-	Die cast zinc, with window	-	0.258 kg
R412006351	with external query	Polycarbonate	Polyamide	0.77 kg

Suitable for use in Ex zones 1, 2, 21, 22.

Technical information

Material	
Reservoir	Polycarbonate Die cast zinc
Protective guard	Polyamide
Seal	Acrylonitrile butadiene rubber

Dimensions

Dimensions in mm

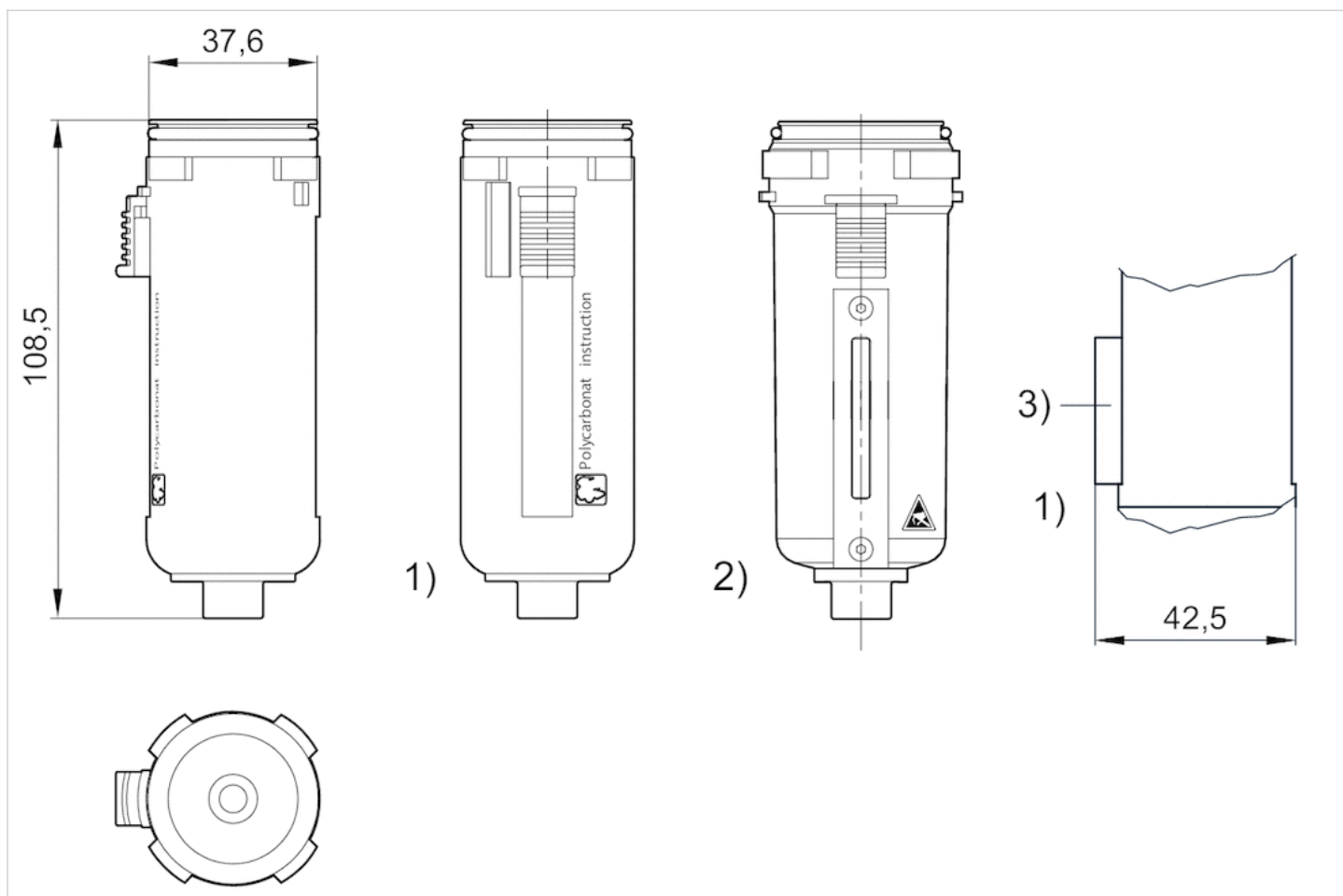

- 1) Plastic reservoir and protective guard with window
- 2) Metal reservoir with inspection glass
- 3) with external query

Mounting plate, Series AS2-MBR-...-



Ambient temperature min./max. -10 ... 50 °C
 Weight 0.065 kg

Technical data

Part No.
R412006368

Scope of delivery incl. 2 mounting screws 3x10 (Torx 10 IP) DIN EN ISO 10664

Technical information

For assembly of the W01 mounting plate, the rear cover of the air preparation unit must be removed.

Technical information

Material	
Housing	Steel, galvanized
Seal	Acrylonitrile butadiene rubber

Dimensions

Dimensions in mm

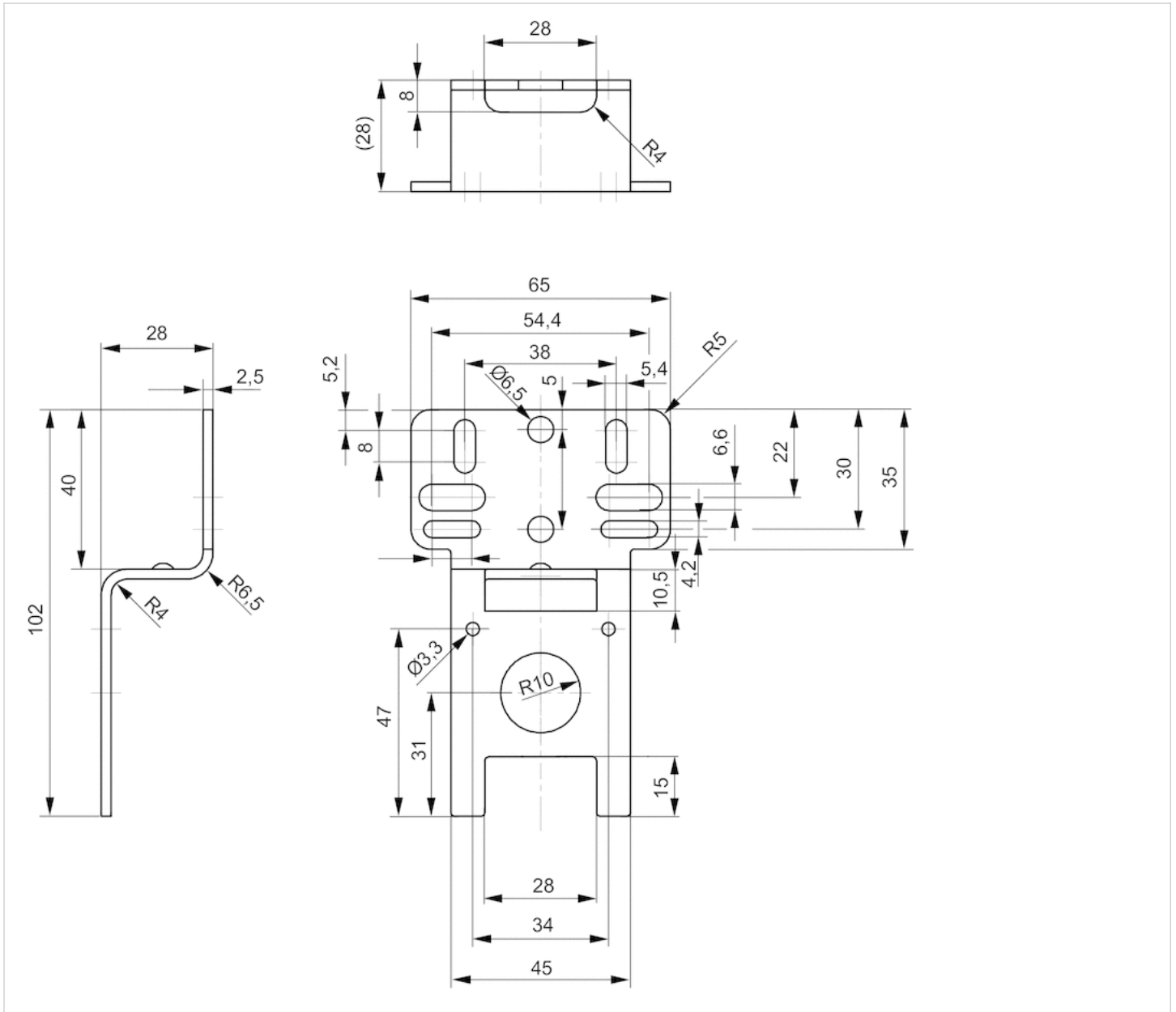

Mounting bracket, Series AS2-MBR-...-W02



Ambient temperature min./max. -10 ... 50 °C
 Weight 0.065 kg

Technical data

Part No.
R412007963

Technical information

Material	
Housing	Steel, galvanized

Dimensions

Dimensions in mm

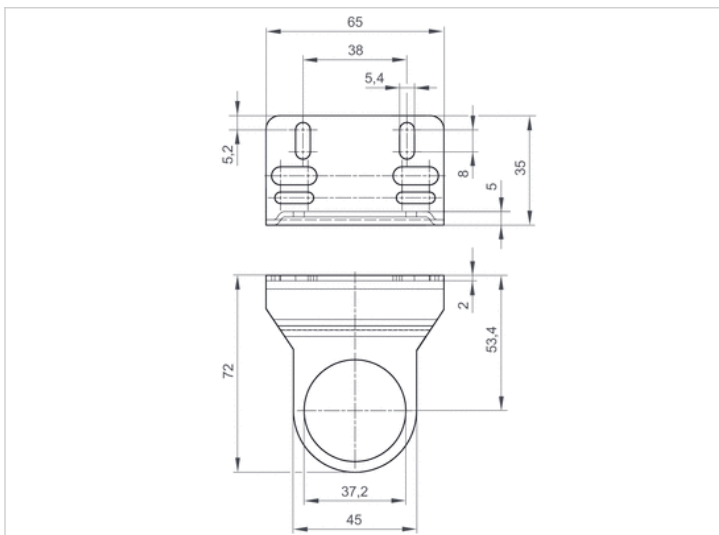

Mounting clip, Series AS2-MBR-...-W03



Ambient temperature min./max.

-10 ... 50 °C

Weight

0.015 kg

Technical data

Part No.

R412006370

Scope of delivery incl. 2 mounting screws M3x53-4.8-A2R according to EN ISO 7046-1 (countersunk screw with type H X-slot), 1x O-ring

Suitable for use in Ex zones 1, 2, 21, 22.

Technical information

Material

Housing	Polyamide
Seal	Acrylonitrile butadiene rubber

Dimensions

Dimensions in mm

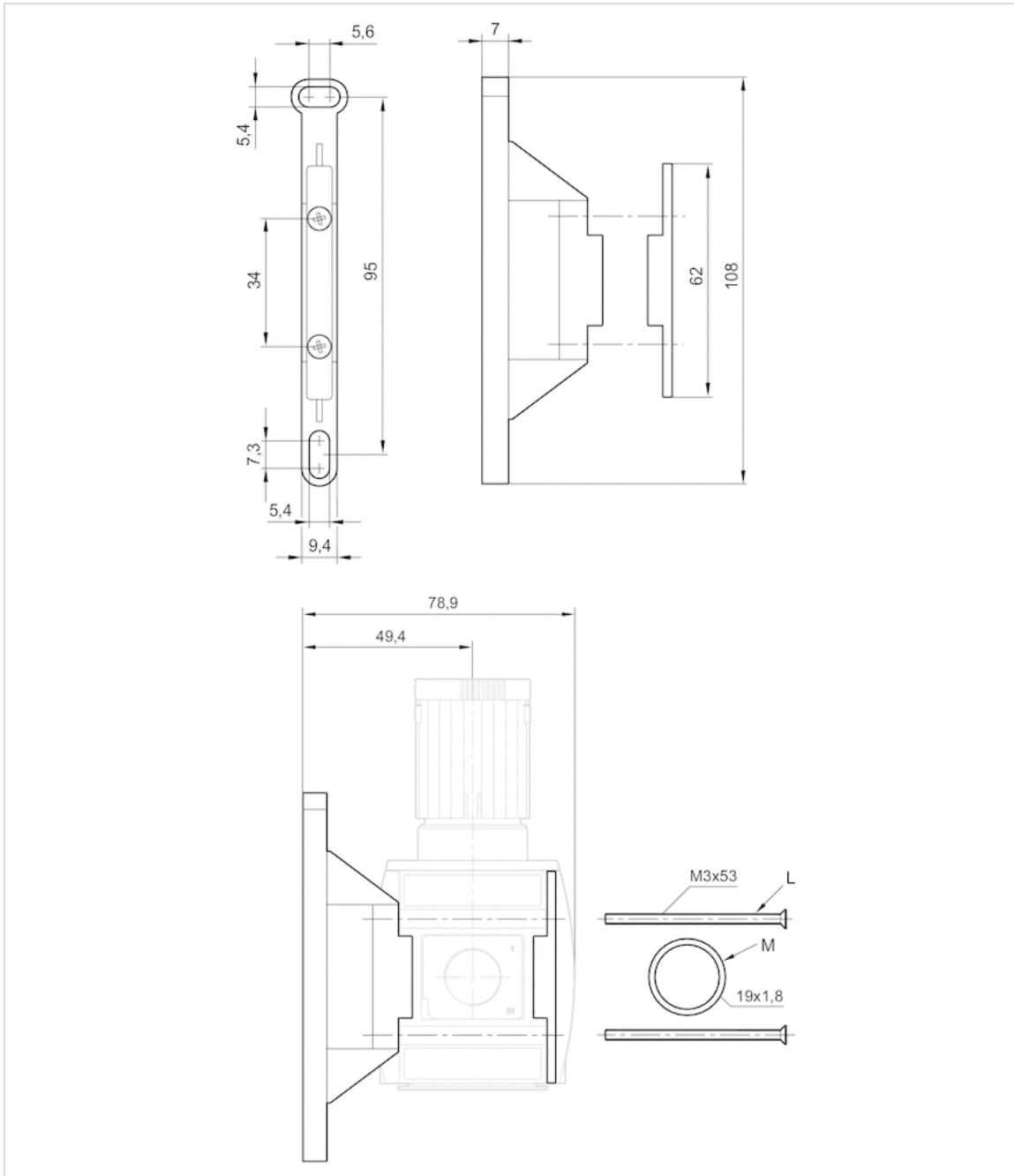

L = Mounting screw
M = O-ring

Block assembly kit, Series AS2-MBR-...-W04



Ambient temperature min./max. -10 ... 50 °C
Weight 0.01 kg

Technical data

Part No.

R412006371

Scope of delivery incl. 2 mounting screws M3x53-4.8-A2R according to EN ISO 7046-1 (countersunk screw with type H X-slot), 1x O-ring

Suitable for use in Ex zones 1, 2, 21, 22.

Technical information

Material

Housing	Polyamide
Seal	Acrylonitrile butadiene rubber

Block assembly kit, Series AS2-MBR-...-W05

- G 1/4 ... G 3/8



Ambient temperature min./max.

-10 ... 50 °C

Weight

0.475 kg

Technical data

Part No.	Port
R412006367	G 3/8
R412006366	G 1/4

Scope of delivery incl. 4 mounting screws M3x53-4.8-A2R according to EN ISO 7046-1 (countersunk screw with type H X-slot), 2x O-ring

Technical information

Material	
Housing	Die cast zinc, painted
Seal	Acrylonitrile butadiene rubber

Dimensions

Dimensions in mm

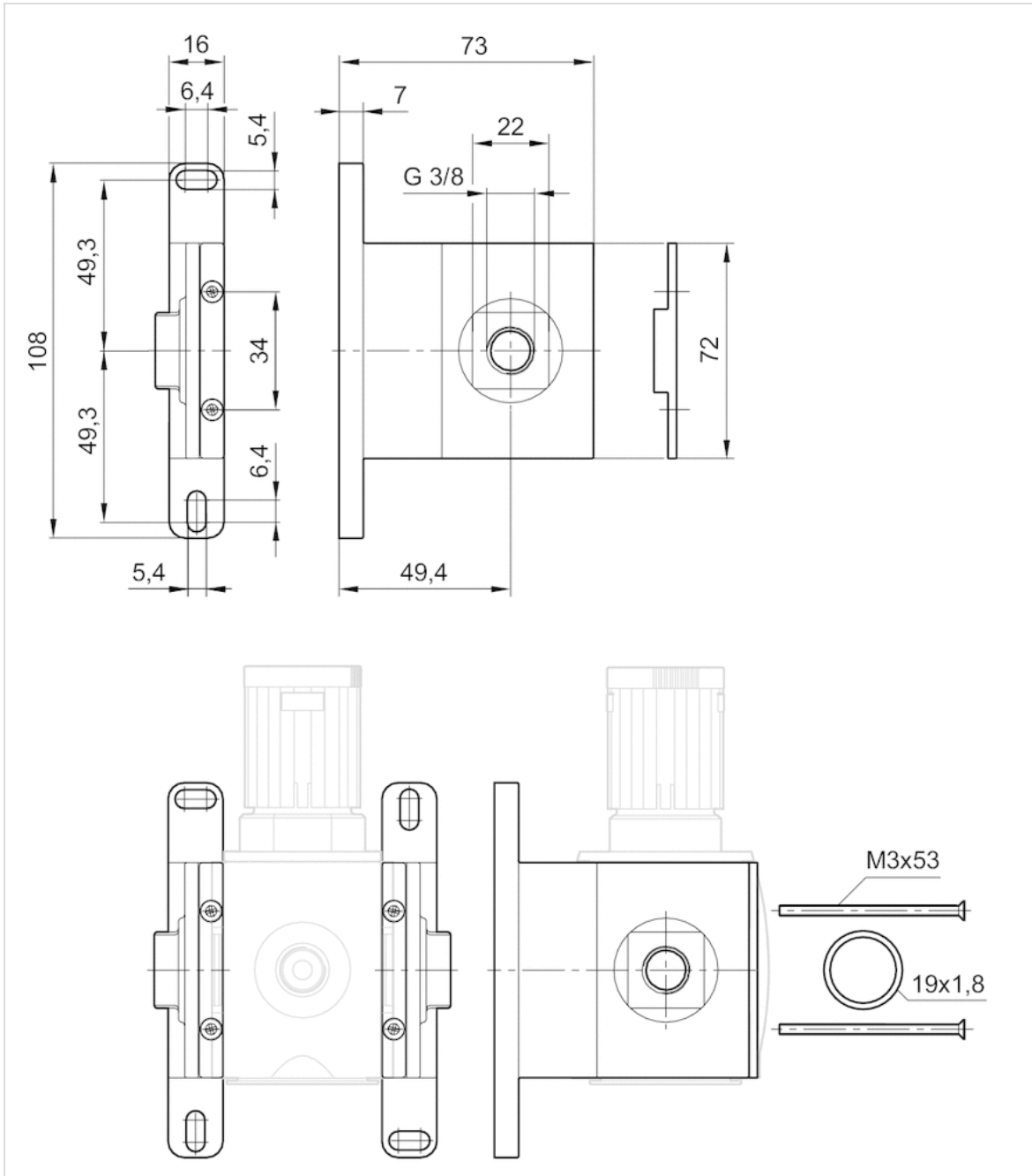

Block assembly kit, Series AS2/AS3- MBR-...-W07



Ambient temperature min./max.

-10 ... 50 °C

Technical data

Part No.	Port
R412010121	G 1/8

scope of delivery incl. seal

Technical information

Material	
Housing	Polyamide
Seal	Acrylonitrile butadiene rubber

Dimensions

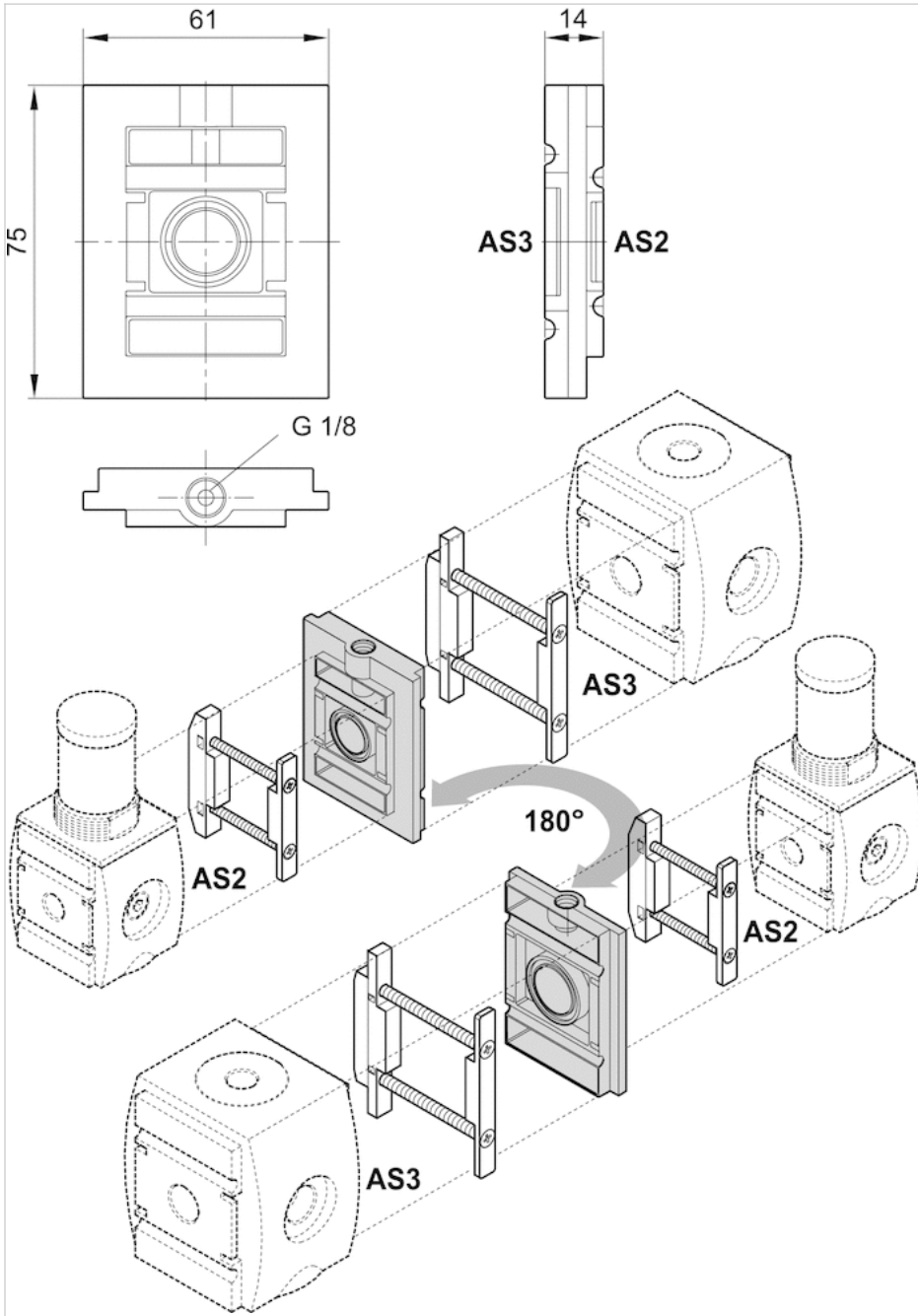

scope of delivery incl. seal

Dimensions

Part No.	A	B	C	D
R412010121	75	61	14	G 1/8

Block assembly kit, Series AS1/AS2- MBR-...-W07



Ambient temperature min./max.

-10 ... 50 °C

Weight

0.055 kg

Technical data

Part No.

R412014759

Scope of delivery incl. 1 blanking screw and 2 mounting strap kits

Technical information

Material

Housing

Polyamide

Seal

Acrylonitrile butadiene rubber

Dimensions

Dimensions in mm

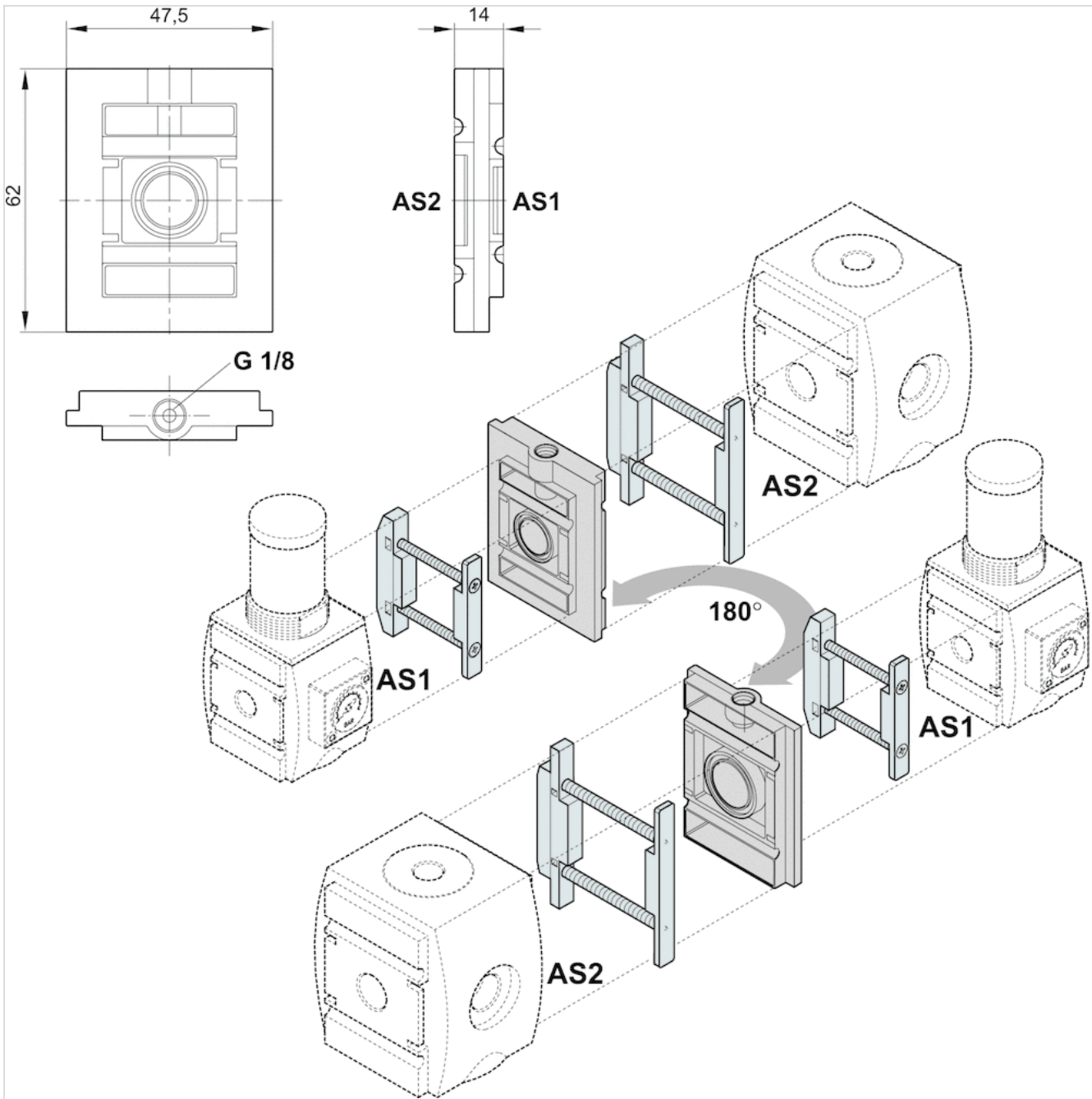

Panel nut, Series AS-MBR-...-W06

- M36x1.5

- for AS2



Ambient temperature min./max.

-10 ... 50 °C

The delivered product may vary from that in the illustration.

Technical data

Part No.	Port	for
R412006372	M36x1.5	AS2

Suitable for use in Ex zones 1, 2, 21, 22.

Technical information

Material	
Housing	Polyamide

Dimensions

Dimensions in mm

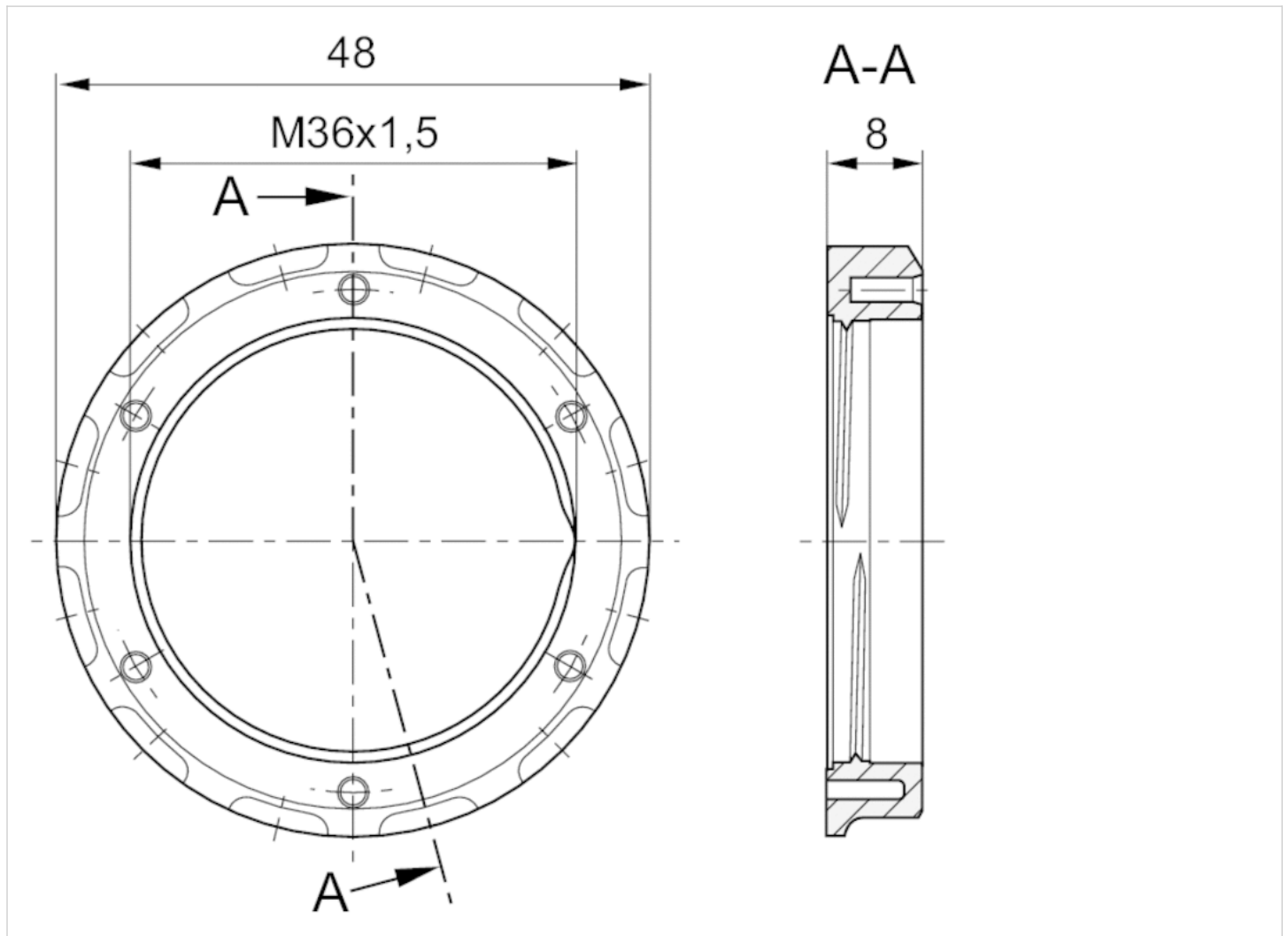

Pressure gauge, Series PG1-SAS

- Back port
- Background color Black
- Scale color White, Grey
- Viewing window Polystyrene
- Units bar
- Units psi



Version	Bourdon tube pressure gauge
Standardization	EN 837-1
Class	2,5
Ambient temperature min./max.	-40 ... 60 °C
Medium	Compressed air
Main scale unit (outside)	bar
Main scale color (outside)	White
Secondary scale unit (inside)	psi
Secondary scale color (inside)	Grey
Background color	Black
Pointer color	White
Weight	See table below

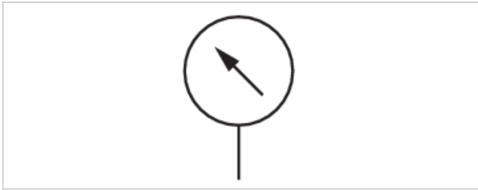

Technical data

Part No.	Compressed air connection	Nominal diameter	Range of application	Display range	Operating pressure	Scale value
R412004407	G 1/4	40 mm	0 bar ... 1.2	0 bar ... 1.6	0 ... 1.6 bar	0.05
R412004408	G 1/4	40 mm	0 bar ... 2	0 bar ... 2.5	0 ... 2.5 bar	0.1
R412004409	G 1/4	40 mm	0 bar ... 3.2	0 bar ... 4	0 ... 4 bar	0.1
R412004410	G 1/4	40 mm	0 bar ... 4	0 bar ... 6	0 ... 6 bar	0.2
R412004411	G 1/4	40 mm	0 bar ... 8	0 bar ... 10	0 ... 10 bar	0.2
R412004412	G 1/4	40 mm	0 bar ... 12	0 bar ... 16	0 ... 16 bar	0.5
R412004413	G 1/4	50 mm	0 bar ... 1.2	0 bar ... 1.6	0 ... 1.6 bar	0.05
R412004414	G 1/4	50 mm	0 bar ... 2	0 bar ... 2.5	0 ... 2.5 bar	0.1
R412004415	G 1/4	50 mm	0 bar ... 3.2	0 bar ... 4	0 ... 4 bar	0.1
R412004416	G 1/4	50 mm	0 bar ... 4	0 bar ... 6	0 ... 6 bar	0.2
R412004417	G 1/4	50 mm	0 bar ... 8 bar	0 bar ... 10 bar	0 ... 10 bar	0.2
R412004418	G 1/4	50 mm	0 bar ... 12	0 bar ... 16	0 ... 16 bar	0.5
R412007898	G 1/4	50 mm	0 bar ... 20	0 bar ... 25	0 ... 25 bar	1
R412004419	G 1/4	63 mm	0 bar ... 1.2	0 bar ... 1.6	0 ... 1.6 bar	0.05
R412004420	G 1/4	63 mm	0 bar ... 2	0 bar ... 2.5	0 ... 2.5 bar	0.1
R412004421	G 1/4	63 mm	0 bar ... 3.2	0 bar ... 4	0 ... 4 bar	0.1
R412004422	G 1/4	63 mm	0 bar ... 4	0 bar ... 6	0 ... 6 bar	0.2
R412004423	G 1/4	63 mm	0 bar ... 8	0 bar ... 10	0 ... 10 bar	0.2
R412004424	G 1/4	63 mm	0 bar ... 12	0 bar ... 16	0 ... 16 bar	0.5

Part No.	Weight	Fig.	
R412004407	0.08 kg	Fig. 1	-
R412004408	0.08 kg	Fig. 1	-
R412004409	0.08 kg	Fig. 1	-
R412004410	0.08 kg	Fig. 1	-
R412004411	0.08 kg	Fig. 1	-
R412004412	0.08 kg	Fig. 1	-
R412004413	0.09 kg	Fig. 2	-
R412004414	0.09 kg	Fig. 2	-
R412004415	0.09 kg	Fig. 2	-
R412004416	0.09 kg	Fig. 2	-
R412004417	0.09 kg	Fig. 2	1)
R412004418	0.09 kg	Fig. 2	1)
R412007898	0.09 kg	Fig. 2	-
R412004419	0.1 kg	Fig. 3	-
R412004420	0.1 kg	Fig. 3	-
R412004421	0.1 kg	Fig. 3	-
R412004422	0.1 kg	Fig. 3	-
R412004423	0.1 kg	Fig. 3	-
R412004424	0.1 kg	Fig. 3	-

1) Suitable for use in Ex zones 1, 2, 21, 22.

Technical information

Material	
Housing	Acrylonitrile butadiene styrene
Thread	Brass
Viewing window	Polystyrene
Seal	Polytetrafluorethylene

Dimensions

Dimensions in mm, Fig. 1

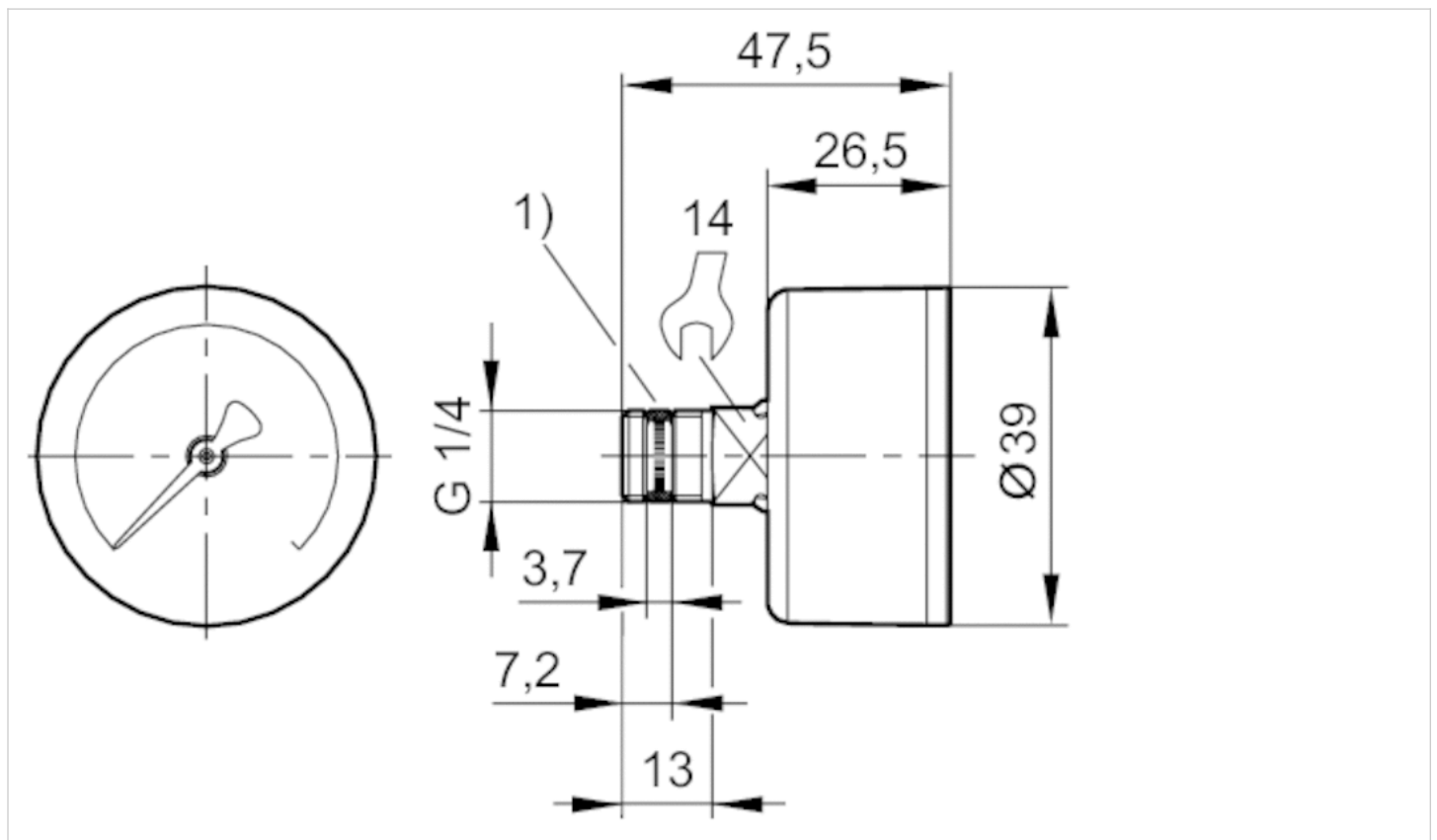

1) Gasket thread

Dimensions in mm, Fig. 2

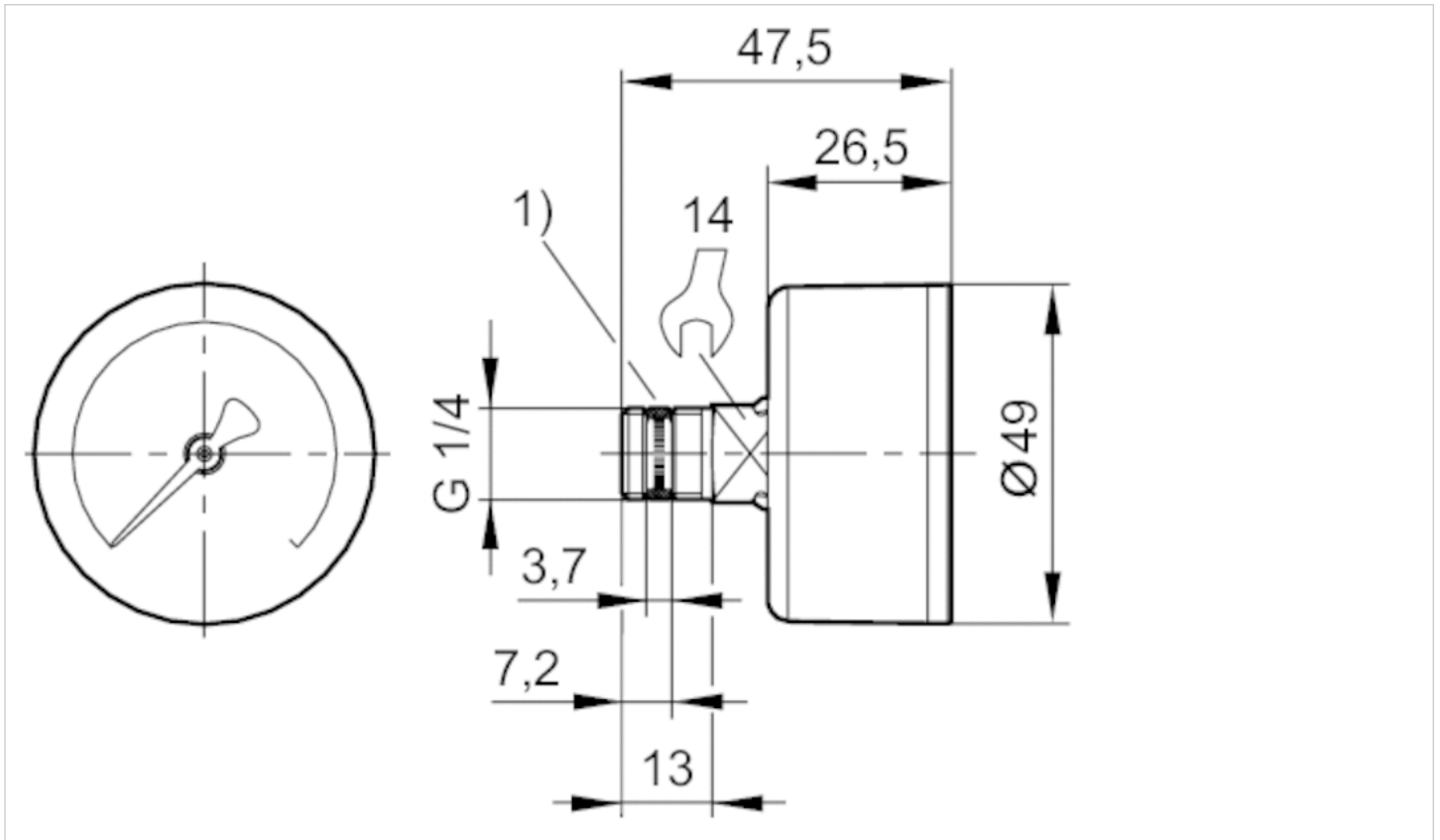

1) Gasket thread

Dimensions in mm, Fig. 3

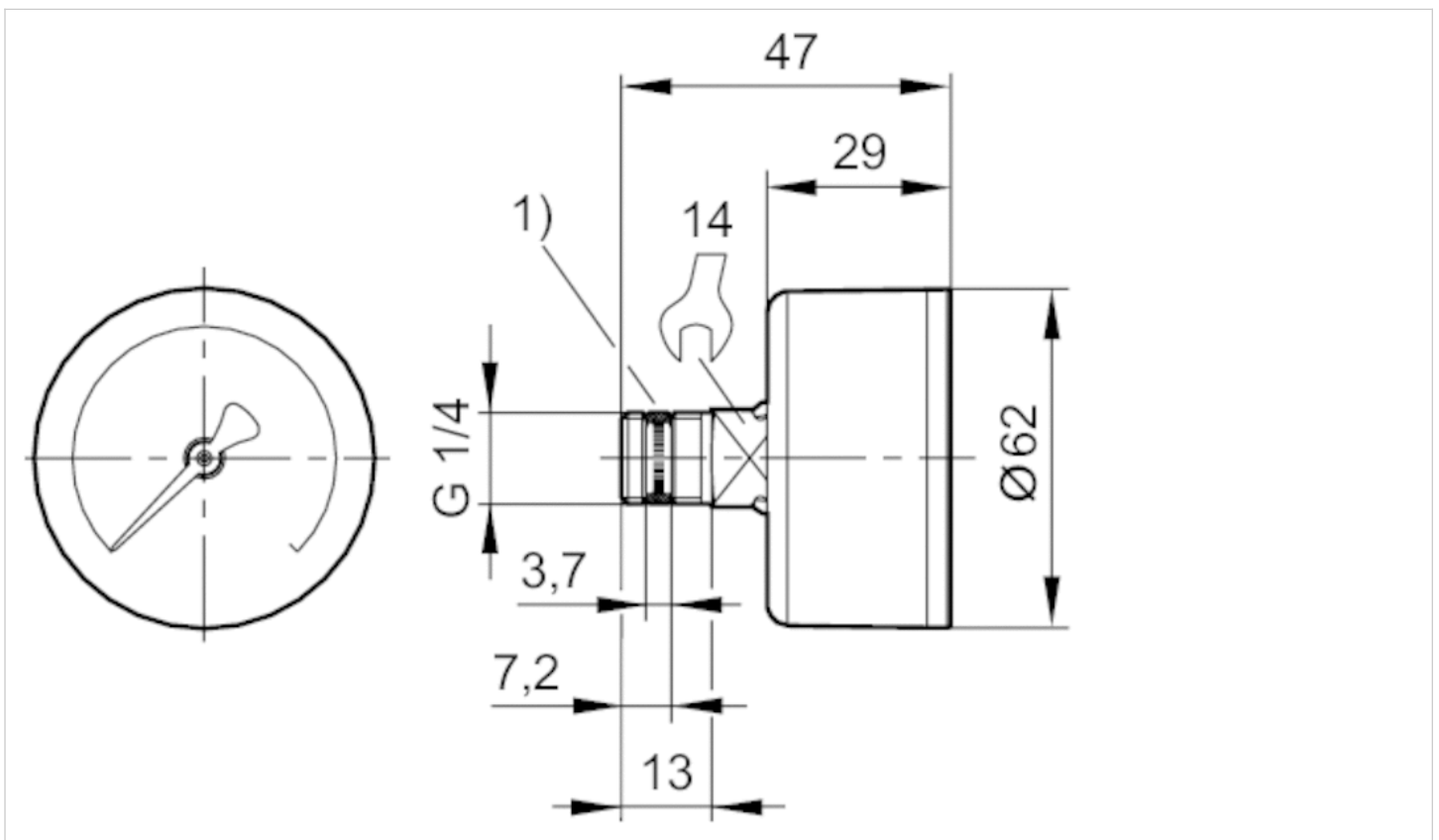

1) Gasket thread

Pressure gauge, Series PG1-SAS-ADJ

- Back port
- with adjustable work area display
- Background color Black
- Scale color White, Grey
- Viewing window Polystyrene
- Units bar
- Units psi

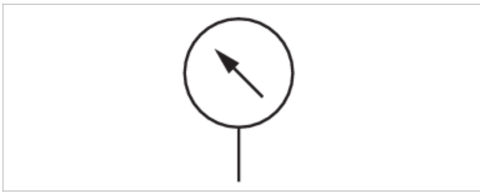

Version	Bourdon tube pressure gauge
Version	with adjustable work area display
Standardization	EN 837-1
Class	2,5
Ambient temperature min./max.	-40 ... 60 °C
Medium	Compressed air
Work area	adjustable work area display
Work Area Display, Color	Red Green
Main scale unit (outside)	bar
Main scale color (outside)	White
Secondary scale unit (inside)	psi
Secondary scale color (inside)	Grey
Background color	Black
Pointer color	White
Weight	0.1 kg

Technical data

Part No.	Compressed air connection	Nominal diameter	Range of application	Display range	Operating pressure	Scale value
R412007867	G 1/4	50 mm	0 bar ... 1.2	0 bar ... 1.6	0 ... 1.6 bar	0.05
R412007868	G 1/4	50 mm	0 bar ... 2	0 bar ... 2.5	0 ... 2.5 bar	0.1
R412007869	G 1/4	50 mm	0 bar ... 3.2	0 bar ... 4	0 ... 4 bar	0.1
R412007870	G 1/4	50 mm	0 bar ... 4	0 bar ... 6	0 ... 6 bar	0.2
R412007871	G 1/4	50 mm	0 bar ... 8	0 bar ... 10	0 ... 10 bar	0.2
R412007872	G 1/4	50 mm	0 bar ... 12	0 bar ... 16	0 ... 16 bar	0.5

Technical information

To set the operating range, the cover (inspection glass) must be removed. To do this, carefully lift the inspection glass by inserting a pointed or flat object in the slot provided for this purpose on the housing circumference.

Technical information

Material	
Housing	Acrylonitrile butadiene styrene
Thread	Brass

Material	
Viewing window	Polystyrene
Seal	Polytetrafluorethylene

Dimensions

Dimensions in mm, Fig. 1

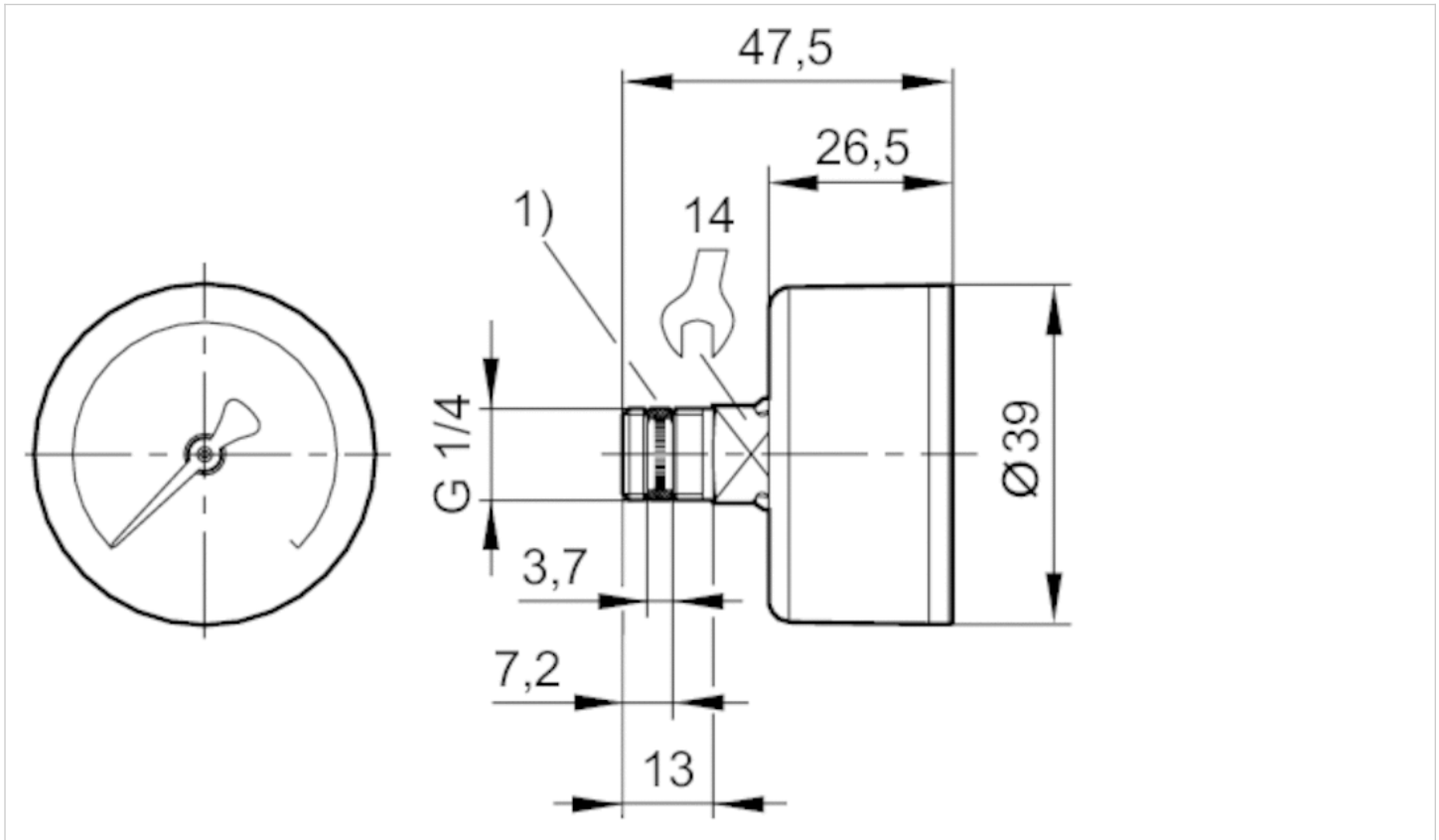

1) Gasket thread

Dimensions in mm

Compressed air connection	Nominal diameter	Ø A	B	C	D	E	F	SW
G 1/4	50 mm	49	47.5	26.5	13	7.2	3.7	14

Pressure gauge, Series PG1-DIM

- for differential pressure measurement for prefilters and microfilters
- flange version
- Background color White
- Scale color Black
- Viewing window Polystyrene
- Units bar
- suitable for ATEX



Version	Diaphragm pressure gauge
Mounting orientation	vertical
Ambient temperature min./max.	0 ... 60 °C
Medium	Compressed air
Color for differential pressure range	Green Red
Main scale unit (outside)	bar
Main scale color (outside)	Black
Background color	White
Pointer color	Black
Weight	0.127 kg

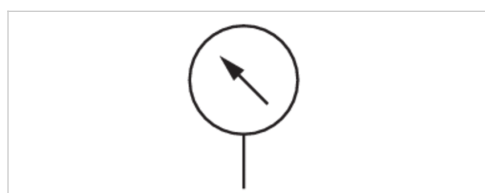

Technical data

Part No.	Range of application	Display range	Operating pressure	Scale value
1827231072	0 ... 0.5 bar	0 ... 0.5 bar	0 ... 16 bar	0.1

Suitable for use in Ex zones 1, 2, 21, 22.

Technical information

Suitable for use in Ex zones 1, 2, 21, 22.

Technical information

Material	
Housing	Polyamide fiber-glass reinforced
Viewing window	Polystyrene
Seal	Acrylonitrile butadiene styrene

Dimensions

Dimensions

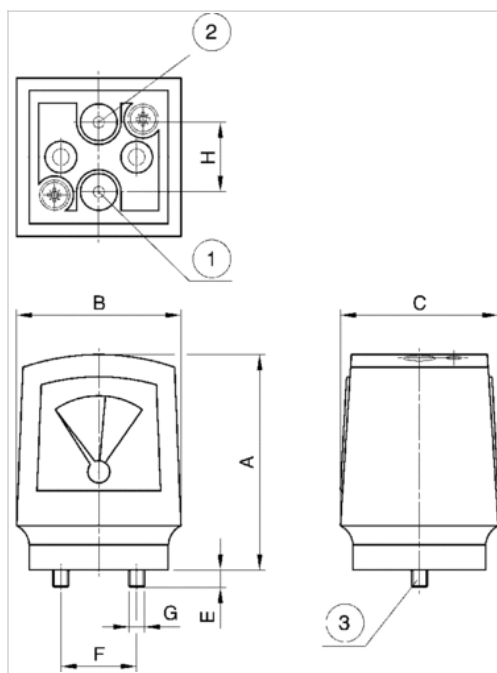

- 1) Input pressure p1
- 2) Output pressure p2
- 3) Mounting screw and 2 O-rings included in scope of delivery

Dimensions in mm

A	B	C	E	F	G	H
68	52	50	6	24	M5	22

contamination display

- for prefilters and microfilters



Weight

0.025 kg

Technical data

Part No.

R412006363

2 mounting screws and 2 O-rings supplied loose, Suitable for use in Ex zones 1, 2, 21, 22.

Technical information

Material

Material

Polyamide

Dimensions

Dimensions in mm

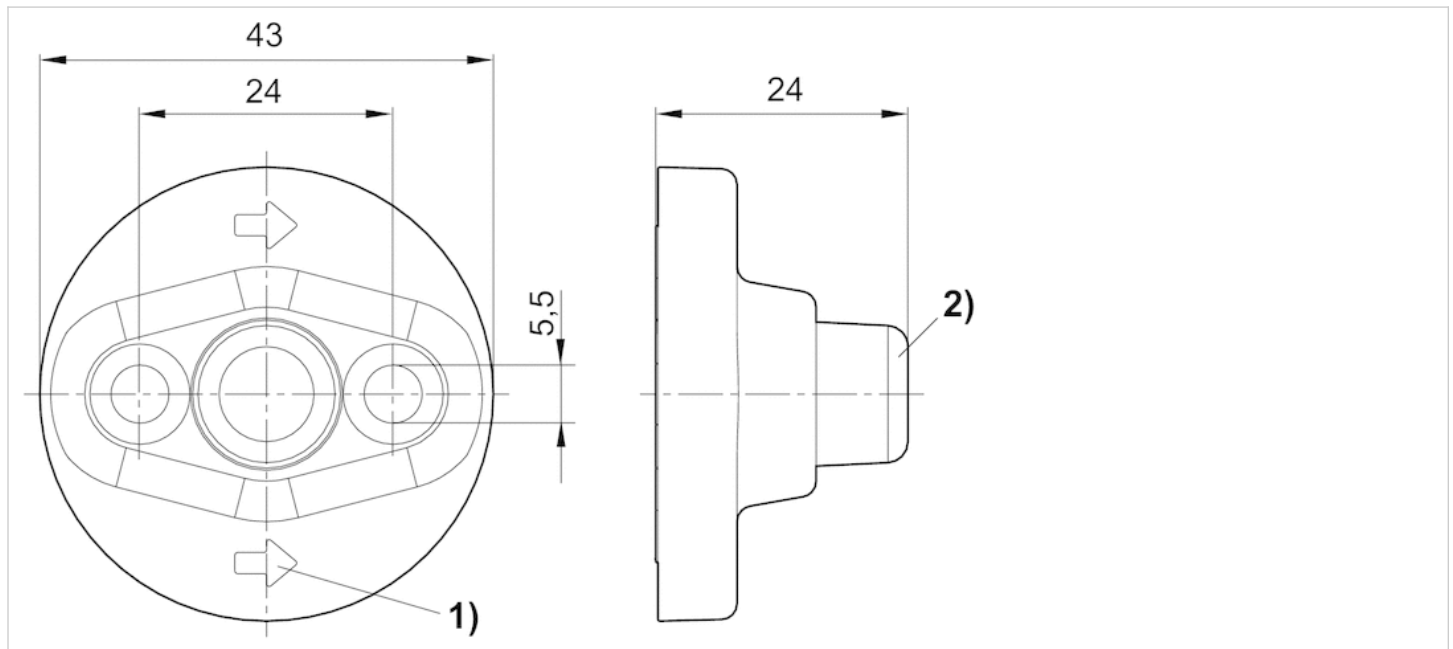

1) Flow direction

2) Display in initial state: green (= Δp 0.35 bar)

Display turns red on contamination of the filter element (= $\Delta p \geq 0.35$ bar).























3/2-directional valve, Series DO16

- 3/2
- Plate connection
- Electrical connection : Plug, ISO 15217, form C
- Manual override : without detent with detent
- With spring return



Version	Poppet valve
Activation	Electrically
Sealing principle	Soft sealing
Working pressure min./max.	See table below
Ambient temperature min./max.	-10 ... 50 °C
Medium temperature min./max.	-10 ... 50 °C
Medium	Compressed air
Max. particle size	5 µm
Oil content of compressed air	0 ... 5 mg/m ³
Nominal flow 1 ▶ 2	See table below
Nominal flow 2 ▶ 3	See table below
Protection class acc. to DIN EN 61140 Electrically	Class I
Protection class with connection	IP65
Duty cycle	100 %
Mounting on manifold strip	PRS strip
mounting screws	M3
Weight	0.035 kg

Technical data

Part No.		MO	Operational voltage	
			DC	AC 50 Hz
0820048002			24 V	-
0820048004			-	24 V
0820048005			-	-
0820048001			-	230 V
0820048026			24 V	-
0820048028			-	24 V
0820048101			-	230 V
0820048029			-	-
0820048025			-	230 V
0820048102			24 V	-
0820048126			24 V	-

Part No.	Operational voltage	Voltage tolerance		
		DC	AC 50 Hz	AC 60 Hz
	AC 60 Hz			
0820048002	-	-10% / +15%	-	-
0820048004	-	-	-10% / +15%	-
0820048005	110 V	-	-	-10% / +15%
0820048001	-	-	-10% / +15%	-

Part No.	Operational voltage	Voltage tolerance	Voltage tolerance	Voltage tolerance
		DC	AC 50 Hz	AC 60 Hz
0820048026	-	-10% / +15%	-	-
0820048028	-	-	-10% / +15%	-
0820048101	-	-	-10% / +15%	-
0820048029	110 V	-	-	-10% / +15%
0820048025	-	-	-10% / +15%	-
0820048102	-	-10% / +15%	-	-
0820048126	-	-10% / +15%	-	-

Part No.	Power consumption	Holding power	Holding power	Switch-on power
	DC	AC 50 Hz	AC 60 Hz	AC 50 Hz
0820048002	2 W	-	-	-
0820048004	-	1.6 VA	-	2.2 VA
0820048005	-	-	1.4 VA	-
0820048001	-	1.6 VA	-	2.2 VA
0820048026	2 W	-	-	-
0820048028	-	1.6 VA	-	2.2 VA
0820048101	-	1.6 VA	-	2.2 VA
0820048029	-	-	1.4 VA	-
0820048025	-	1.6 VA	-	2.2 VA
0820048102	2 W	-	-	-
0820048126	2 W	-	-	-

Part No.	Switch-on power	Nominal flow 1 ▶ 2	Nominal flow 2 ▶ 3	Working pressure min./max.
	AC 60 Hz			
0820048002	-	25 l/min	36 l/min	0 ... 10 bar
0820048004	-	25 l/min	36 l/min	0 ... 10 bar
0820048005	2 VA	25 l/min	36 l/min	0 ... 10 bar
0820048001	-	25 l/min	36 l/min	0 ... 10 bar
0820048026	-	25 l/min	36 l/min	0 ... 10 bar
0820048028	-	25 l/min	36 l/min	0 ... 10 bar
0820048101	-	16 l/min	19 l/min	0 ... 6 bar
0820048029	2 VA	25 l/min	36 l/min	0 ... 10 bar
0820048025	-	25 l/min	36 l/min	0 ... 10 bar
0820048102	-	20 l/min	26 l/min	0 ... 8 bar
0820048126	-	20 l/min	26 l/min	0 ... 8 bar

Nominal flow Q_n at 6 bar and $\Delta p = 1$ bar, MO = Manual override

Technical information

The min. control pressure must be adhered to, since otherwise faulty switching and valve failure may result!

The pressure dew point must be at least 15 °C under ambient and medium temperature and may not exceed 3 °C .

The oil content of compressed air must remain constant during the life cycle.

Use only the approved oils from AVENTICS. Further information can be found in the "Technical information" document (available in the MediaCentre).

Technical information

Material	
Housing	polyphenylene sulfide Polyamide fiber-glass reinforced
Seals	Acrylonitrile butadiene rubber

Dimensions

Dimensions

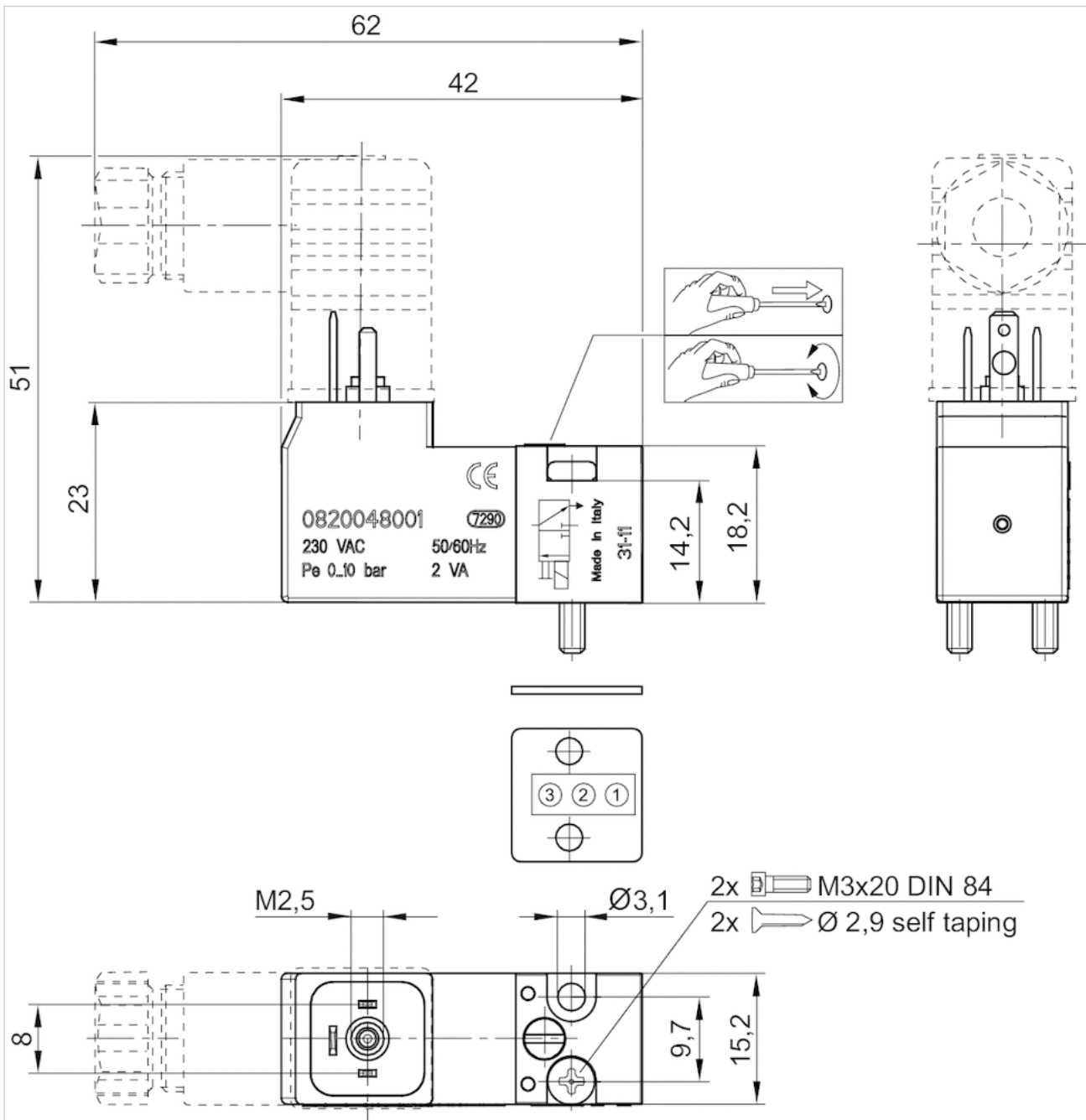

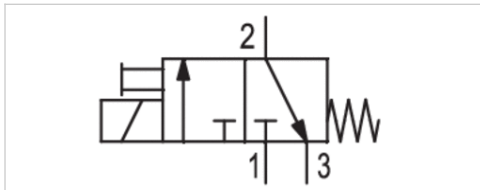

3/2-directional valve, Series DO16

- 3/2
- NC
- Plate connection
- Electrical connection : M12, 3-pin
- Manual override : without detent
- With spring return



Version	Poppet valve
Activation	Electrically
Sealing principle	Soft sealing
Working pressure min./max.	0 ... 10 bar
Ambient temperature min./max.	-10 ... 50 °C
Medium temperature min./max.	-10 ... 50 °C
Medium	Compressed air
Max. particle size	5 µm
Oil content of compressed air	0 ... 5 mg/m ³
Nominal flow 1 ▶ 2	18 l/min
Nominal flow 2 ▶ 3	24 l/min
Protection class acc. to DIN EN 61140	Class I
Electrically	
Duty cycle	100 %
Mounting on manifold strip	PRS strip
Weight	0.035 kg

Technical data

Part No.	MO		Operational voltage	Power consumption		
				DC	DC	
R412013391		NC	24 V		1.5 W	1)
R412019226		NC	24 V		1.5 W	2)

1) Pilot valve only

2) Incl. pilot valve, seal, screws, and manual

Technical information

The min. control pressure must be adhered to, since otherwise faulty switching and valve failure may result!

The pressure dew point must be at least 15 °C under ambient and medium temperature and may not exceed 3 °C .

The oil content of compressed air must remain constant during the life cycle.

Use only the approved oils from AVENTICS. Further information can be found in the "Technical information" document (available in the MediaCentre).

Technical information

Material

Housing	polyphenylene sulfide Polyamide fiber-glass reinforced
Seals	Acrylonitrile butadiene rubber

Dimensions

Dimensions

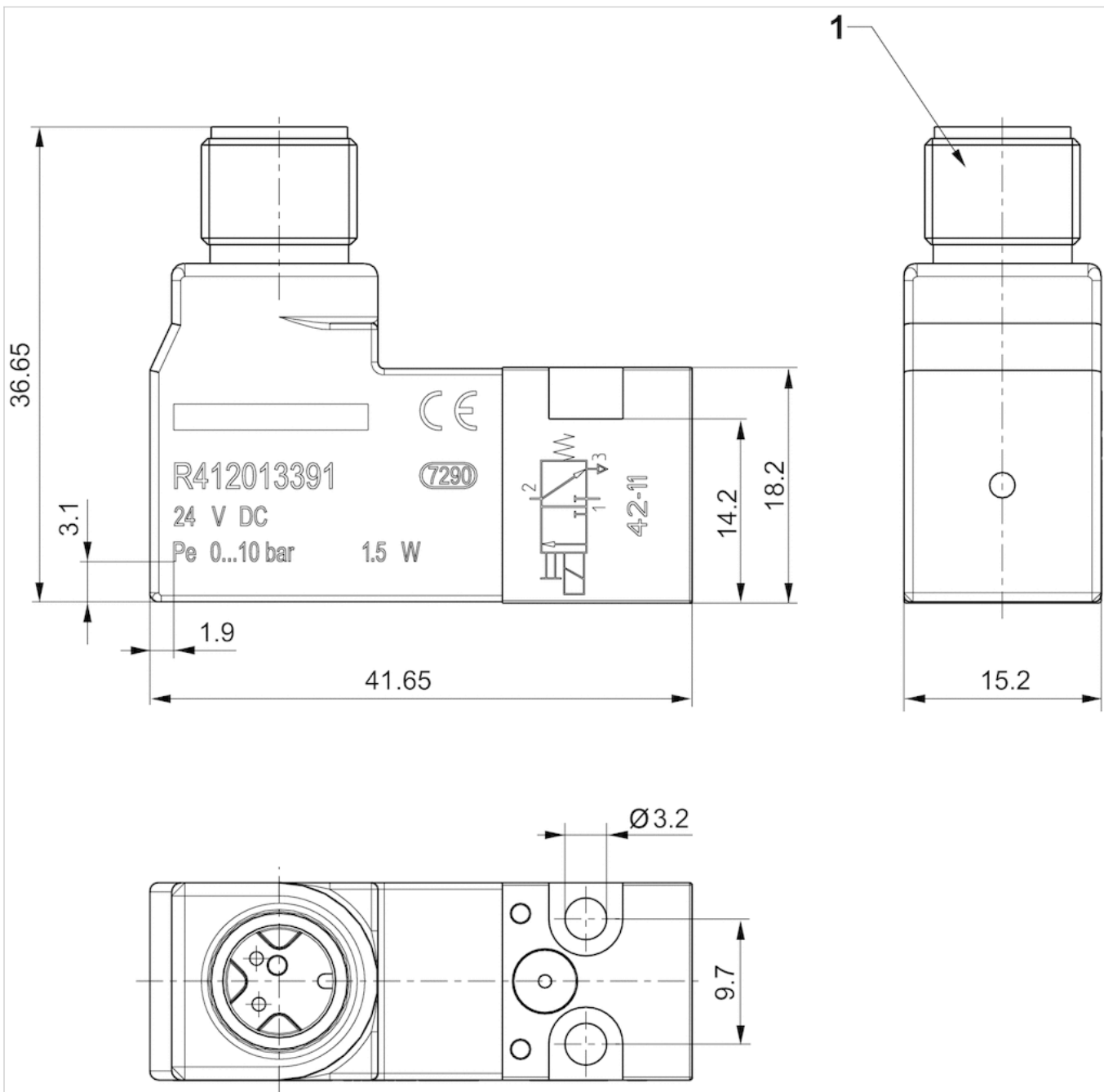

1) Port for plug M12x1

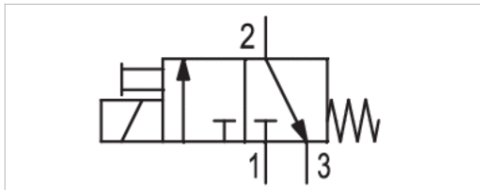

3/2-directional valve, Series DO16

- 3/2
- NC
- Plate connection
- Electrical connection : M12, 3-pin
- Manual override : without detent
- With spring return



Version	Poppet valve
Activation	Electrically
Sealing principle	Soft sealing
Working pressure min./max.	0 ... 10 bar
Ambient temperature min./max.	-10 ... 50 °C
Medium temperature min./max.	-10 ... 50 °C
Medium	Compressed air
Max. particle size	5 µm
Oil content of compressed air	0 ... 5 mg/m ³
Nominal flow 1 ▶ 2	18 l/min
Nominal flow 2 ▶ 3	24 l/min
Protection class acc. to DIN EN 61140	Class I
Electrically	
Duty cycle	100 %
Mounting on manifold strip	PRS strip
Weight	0.035 kg

Technical data

Part No.	MO		Operational voltage	Power consumption		
				DC	DC	
R412013391		NC	24 V		1.5 W	1)
R412019226		NC	24 V		1.5 W	2)

1) Pilot valve only

2) Incl. pilot valve, seal, screws, and manual

Technical information

The min. control pressure must be adhered to, since otherwise faulty switching and valve failure may result!

The pressure dew point must be at least 15 °C under ambient and medium temperature and may not exceed 3 °C .

The oil content of compressed air must remain constant during the life cycle.

Use only the approved oils from AVENTICS. Further information can be found in the "Technical information" document (available in the MediaCentre).

Technical information

Material

Housing	polyphenylene sulfide Polyamide fiber-glass reinforced
Seals	Acrylonitrile butadiene rubber

Dimensions

Dimensions

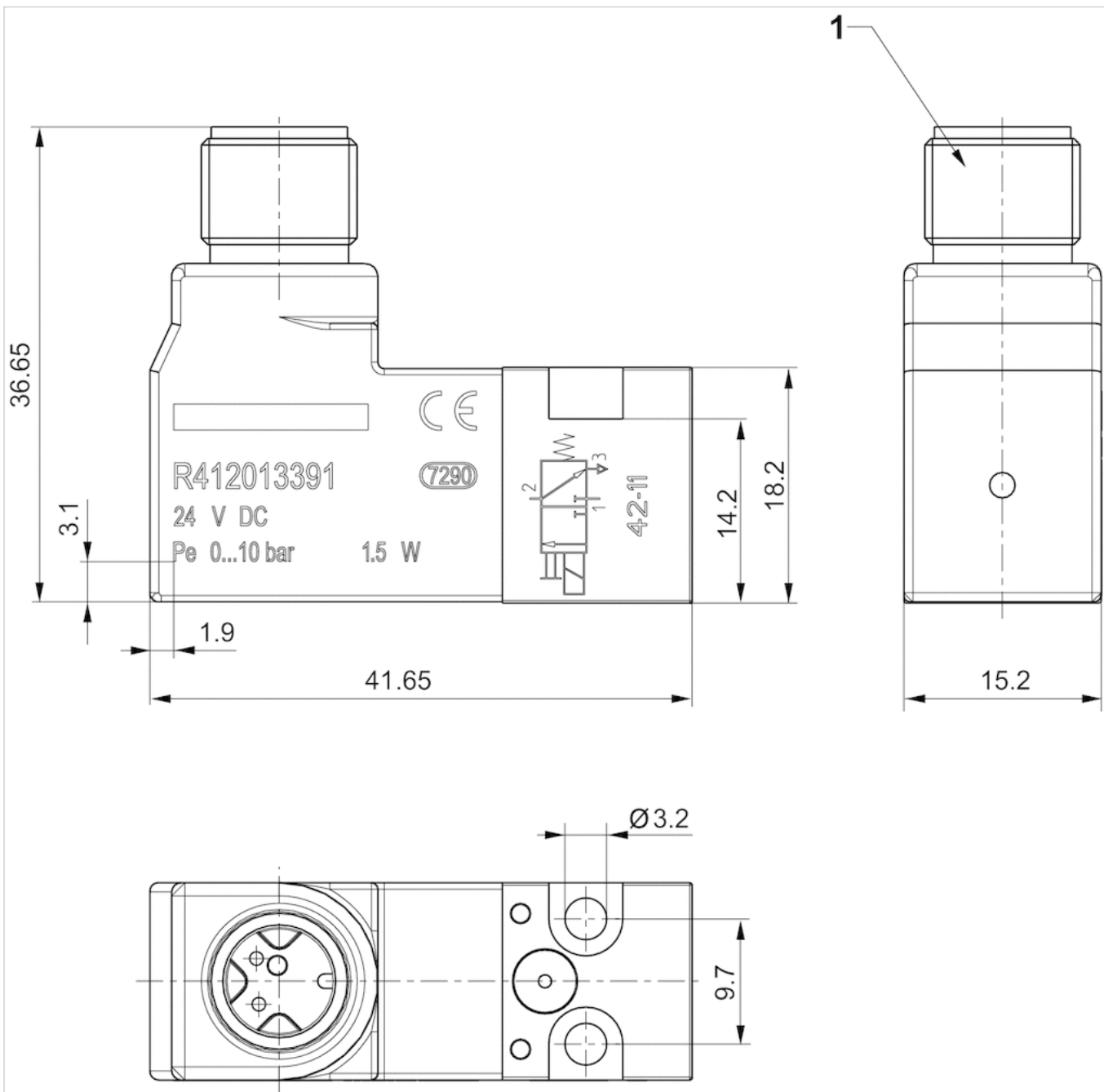

1) Port for plug M12x1



3/2-directional valve, Series DO30

- 3/2
- Pilot valve width : 30 mm
- Plate valve with pipe connection
- Compressed air connection output : CNOMO
- Electrical connection : Plug, EN 175301-803, form A
- Manual override : without detent with detent
- With spring return
- suitable for ATEX



Version	Poppet valve
Activation	Electrically
Sealing principle	Soft sealing
Standards	CNOMO / NFE 49-003-1
Working pressure min./max.	0 ... 10 bar
Ambient temperature min./max.	-10 ... 50 °C
Medium temperature min./max.	-10 ... 50 °C
Medium	Compressed air
Max. particle size	5 µm
Oil content of compressed air	0 ... 5 mg/m ³
Nominal flow 1 ▶ 2	See table below
Nominal flow 2 ▶ 3	See table below
Protection class with connection	IP65
Compatibility index	15
Duty cycle	100 %
Mounting on manifold strip mounting screws	P-strip M4
Weight	0.06 kg

Technical data

Part No.	MO	Compressed air connection	
		Input	Output
0820019985		CNOMO	CNOMO
0820019980		CNOMO	CNOMO

Part No.	Compressed air connection		Nominal flow 1 ▶ 2	Nominal flow 2 ▶ 3
	Exhaust			
0820019985	M5		68 l/min	90 l/min
0820019980	M5		65 l/min	80 l/min

Part No.	basic valve with electrical connector	Power consumption	ATEX
0820019985	Basic valve without coil	Higher voltage tolerance	suitable for ATEX
0820019980	Basic valve without coil	Higher voltage tolerance	suitable for ATEX

Nominal flow Q_n at 6 bar and Δp = 1 bar, MO = Manual override
pilot valve without coil

Technical information

The min. control pressure must be adhered to, since otherwise faulty switching and valve failure may result!
 The pressure dew point must be at least 15 °C under ambient and medium temperature and may not exceed 3 °C .
 The oil content of compressed air must remain constant during the life cycle.
 Use only the approved oils from AVENTICS. Further information can be found in the “Technical information” document (available in the MediaCentre).

ATEX optional: ATEX version can be produced by combining the basic valve without coil with an ATEX coil. ATEX ID: see ATEX coils catalog page.

Technical information

Material

Housing	Plastic
Seals	Fluorocaoutchouc

Dimensions

Dimensions

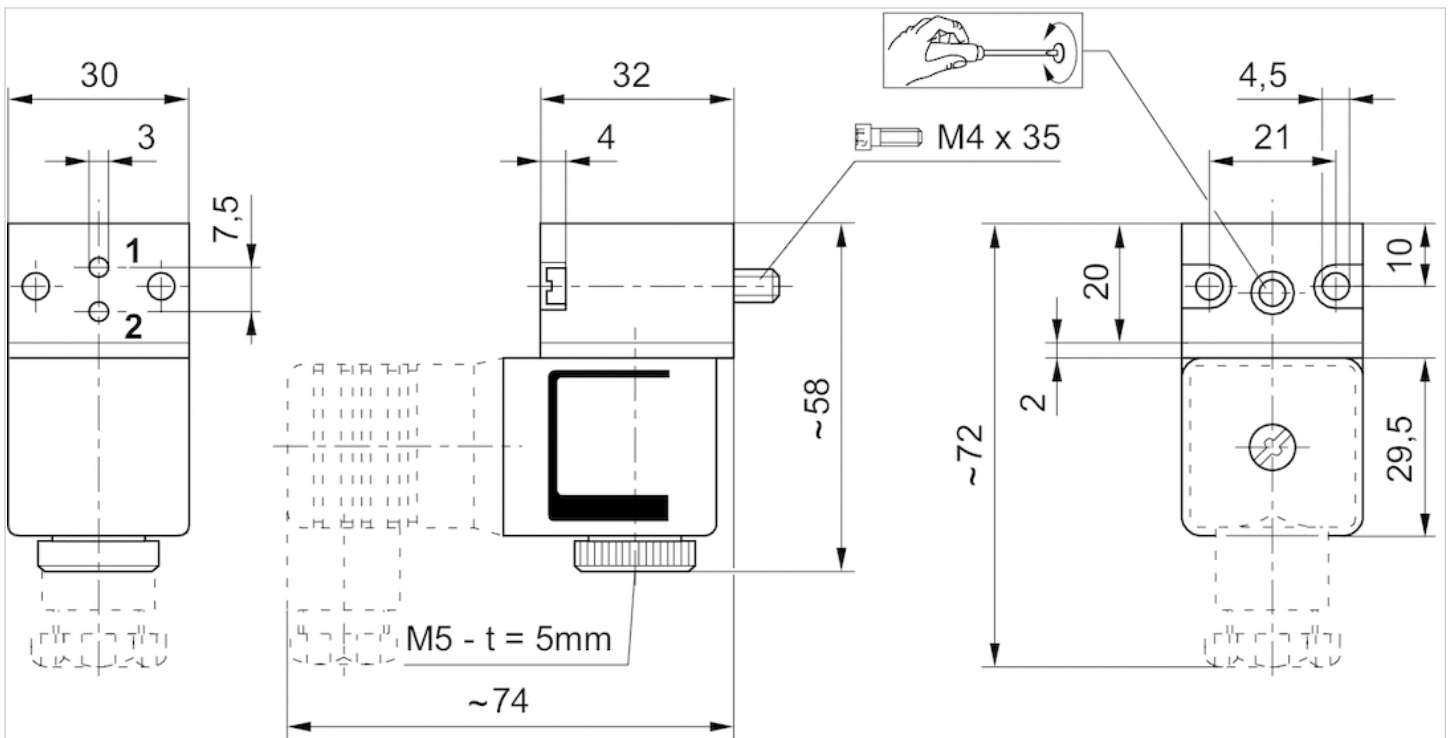

t = depth

Coil, Series CO1

- Cable with valve plug connector
- Coil width 30 mm
- Power consumption DC 3.25 W
- Holding power AC 2.9-3 VA
- Switch-on power AC 3-3.1 VA
- ATEX

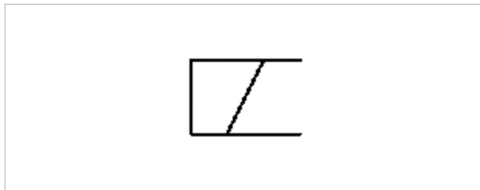

Certificates	ATEX
ATEX class G	II 2G Ex mb IIC T4 Gb
ATEX class D	II 2D Ex mb tb IIIC T130°C Db IP65
Ambient temperature min./max.	-20 ... 50 °C
Protection class	IP65
Duty cycle ED	100 %
Compatibility index	14
Weight	See table below

Technical data

Part No.	Operational voltage	Operational voltage	Operational voltage
	DC	AC 50 Hz	AC 60 Hz
1827414297	-	230 V	230 V
1827414298	-	230 V	230 V
1827414299	-	110 V	110 V
1827414303	24 V	-	-
1827414304	24 V	-	-

Part No.	Voltage tolerance	Voltage tolerance	Power consumption	Holding power
	DC	AC 50 Hz	DC	AC 50 Hz
1827414297	-	-10% / +10%	-	3 VA
1827414298	-	-10% / +10%	-	3 VA
1827414299	-	-10% / +10%	-	2.9 VA
1827414303	-10% / +10%	-	3.25 W	-
1827414304	-10% / +10%	-	3.25 W	-

Part No.	Switch-on power	Cable length	Weight
	AC 50 Hz		
1827414297	3.1 VA	3 m	0.38 kg
1827414298	3.1 VA	10 m	0.91 kg
1827414299	3 VA	3 m	0.38 kg

Part No.	Switch-on power	Cable length	Weight
	AC 50 Hz		
1827414303	-	3 m	0.38 kg
1827414304	-	10 m	0.91 kg

Dimensions

Dimensions

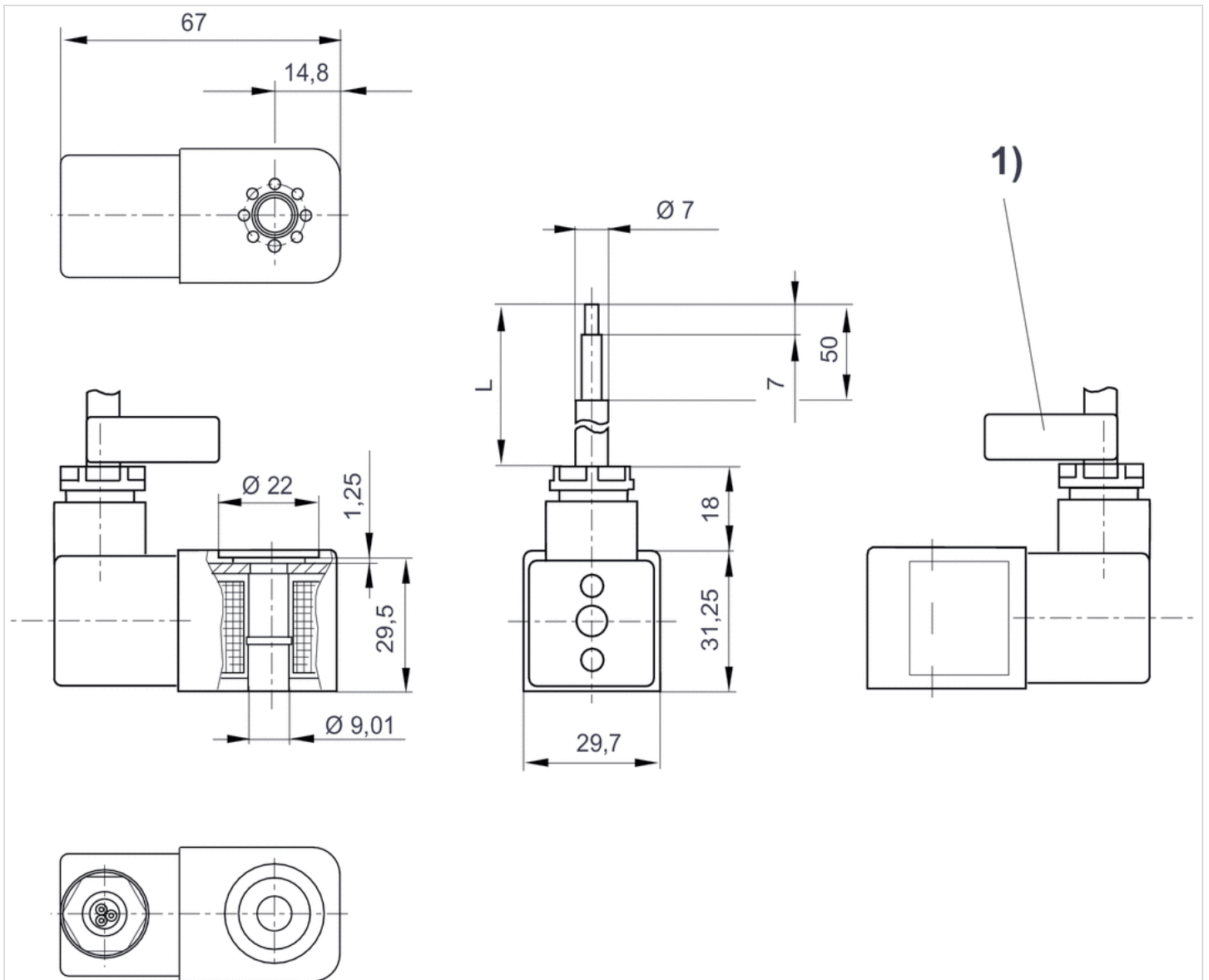

L = cable length

1) Cable ID band with serial number





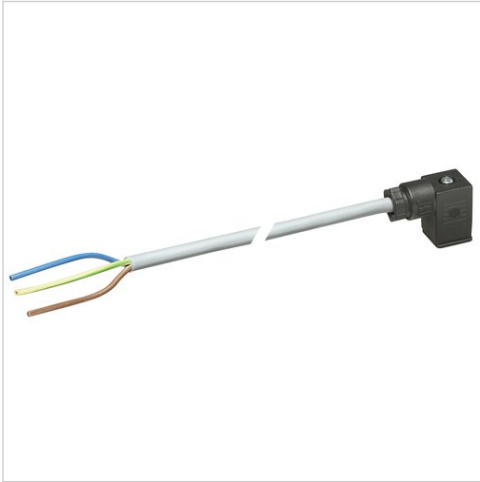

Valve plug connector, series CON-VP

- Socket form C 2+E angled 90°
- open cable ends 3-pin
- with cable
- unshielded

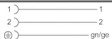

Ambient temperature min./max.	-20 ... 80 °C
Operational voltage	See table below
Protection class	IP67
Wire cross-section	0.75 mm ²
Mounting screw tightening torque	0.4 Nm
Weight	See table below

Technical data

Part No.		Operational voltage	Max. current	Protective circuit	Contact assignment
1834484213		230 V AC/DC	6 A	-	2+E
1834484215		230 V AC/DC	6 A	-	2+E
1834484205		24 V AC/DC	6 A	Z-diode	2+E
1834484207		24 V AC/DC	6 A	Z-diode	2+E
1834484209		230 V AC/DC	6 A	Varistor	2+E
1834484211		230 V AC/DC	6 A	Varistor	2+E
1834484236		24 V AC/DC	6 A	Z-diode	2+E

Part No.	LED status display	Number of wires	Cable-Ø	Cable length	Weight	Fig.	
1834484213	-	3	5.9 mm	3 m	0.183 kg	Fig. 2	-
1834484215	-	3	5.9 mm	5 m	0.308 kg	Fig. 2	-
1834484205	Yellow	3	5.9 mm	3 m	0.185 kg	Fig. 2	1)
1834484207	Yellow	3	5.9 mm	5 m	0.298 kg	Fig. 2	1)
1834484209	Yellow	3	5.9 mm	3 m	0.194 kg	Fig. 2	1)
1834484211	Yellow	3	5.9 mm	5 m	0.285 kg	Fig. 2	1)
1834484236	Yellow	3	5.9 mm	10 m	0.571 kg	Fig. 2	1)

1) Scope of delivery incl. flat gasket

Technical information

The specified protection class is only valid in assembled and tested state.

Technical information

Material

Seals	caoutchouc/butadiene caoutchouc
Cable sheath	Polyvinyl chloride

Dimensions

Fig. 1

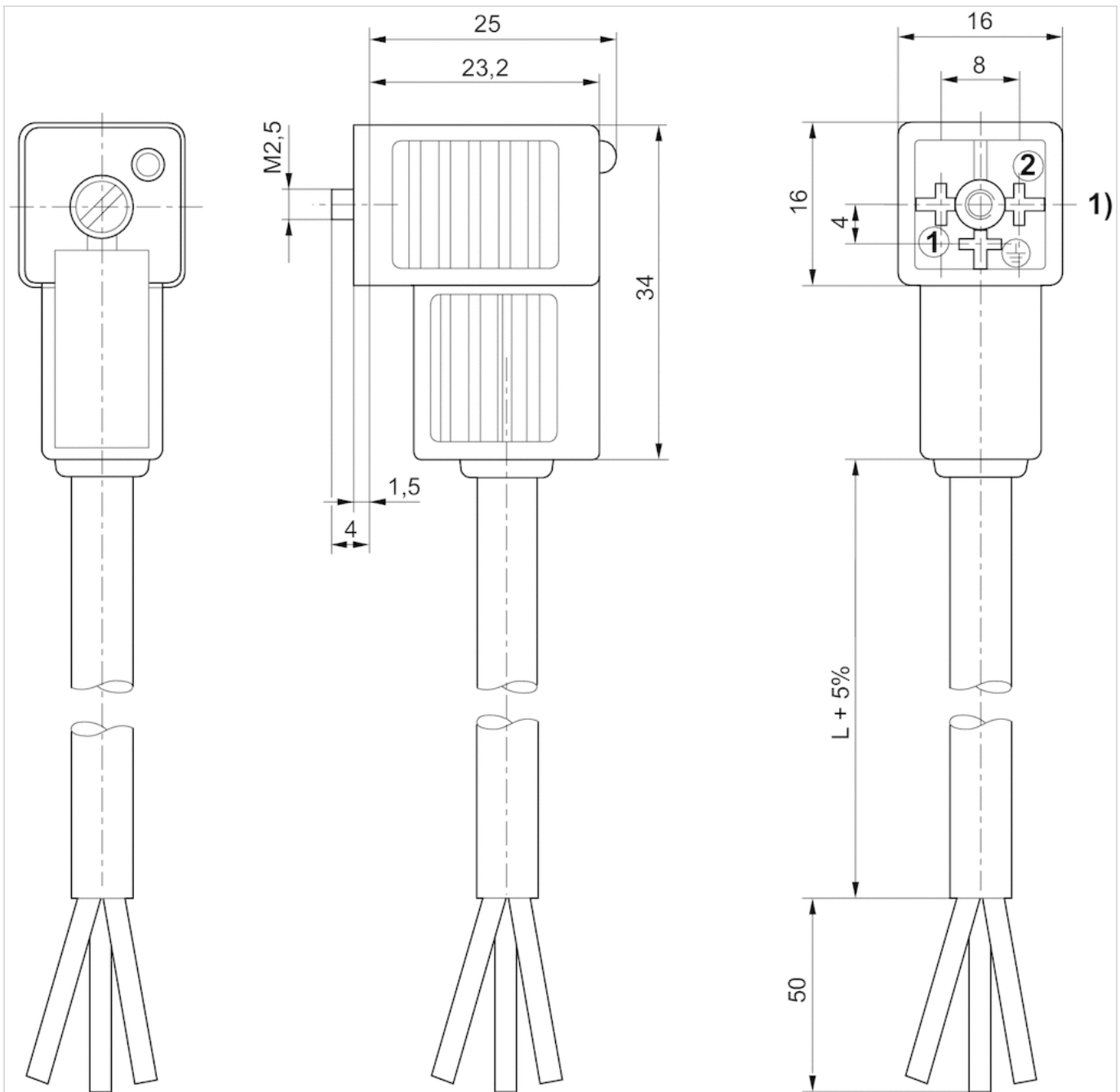

1) 0° female insert

Fig. 2

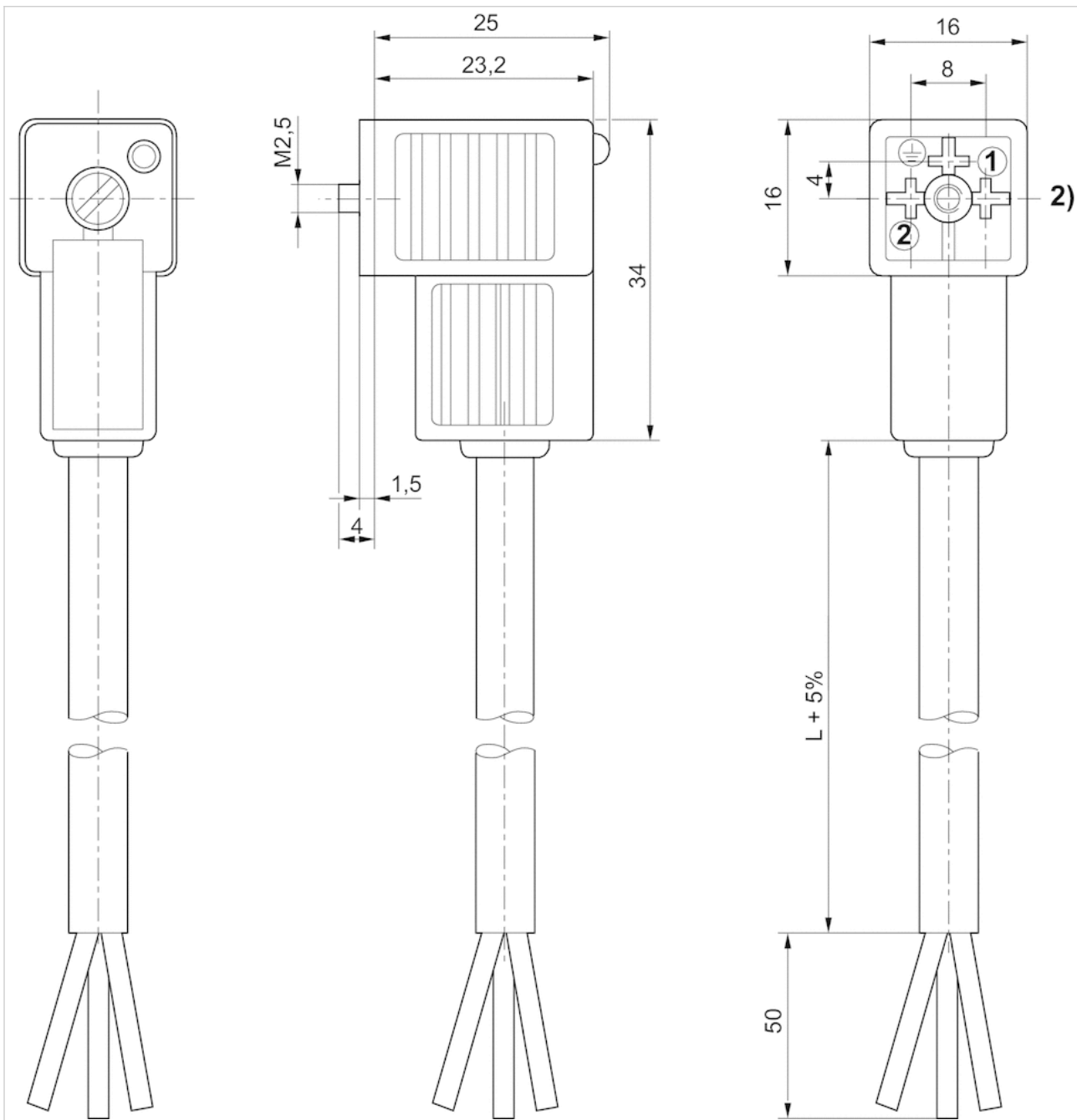

2) 180° female insert

Round plug connector, Series CON-RD

- Socket M12x1 5-pin A-coded angled 90°
- open cable ends
- for DeviceNet
- with cable
- unshielded



Ambient temperature min./max.	-40 ... 85 °C
Operational voltage	48 V AC/DC
Protection class	IP65
Wire cross-section	0.34 mm ²
Weight	See table below

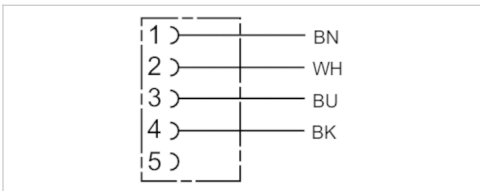

Technical data

Part No.	Max. current	Number of wires	Cable-Ø	Cable length	Weight
1834484259	4 A	4	5.2 mm	3 m	0.126 kg
1834484260	4 A	4	5.2 mm	5 m	0.195 kg
1834484261	4 A	4	5.2 mm	10 m	0.38 kg

Technical information

The specified protection class is only valid in assembled and tested state.

Technical information

Material	
Cable sheath	Polyurethane

Dimensions

Dimensions

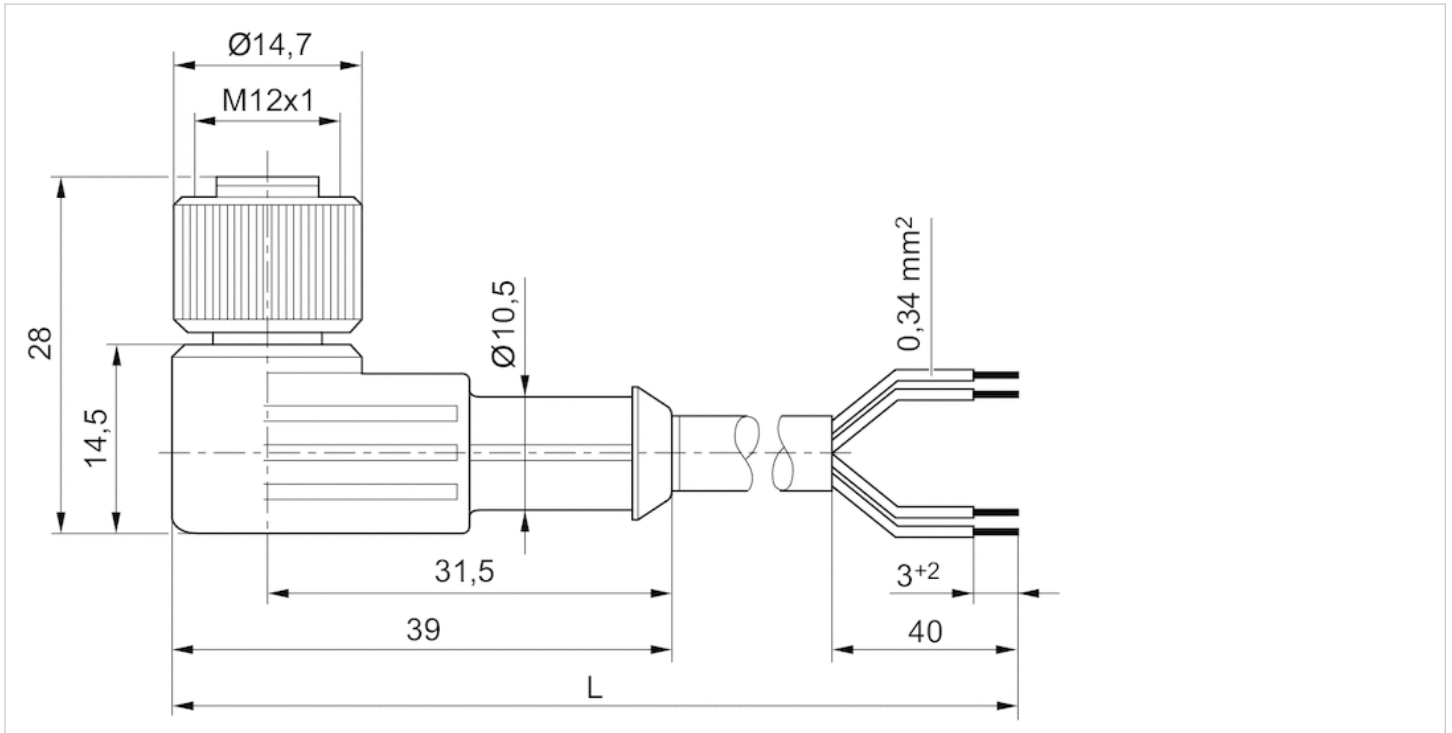

L = length

Pin assignments

Pin assignment, socket

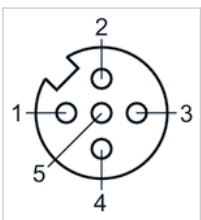

- (1) BN=brown
- (2) WH=white
- (3) BU=blue
- (4) BK=black
- (5) not assigned

Round plug connector, Series CON-RD

- Socket M12x1 5-pin A-coded straight 180°
- open cable ends
- with cable
- unshielded

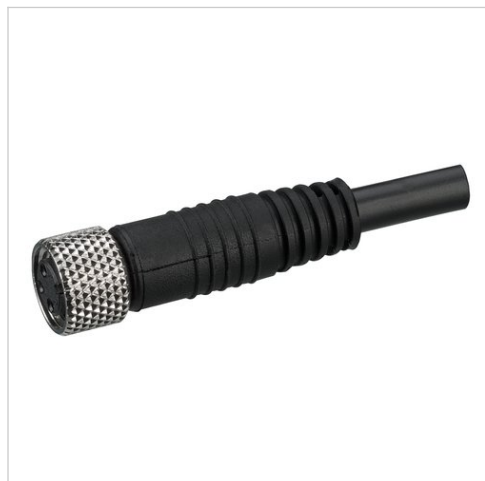

Ambient temperature min./max.	-25 ... 70 °C
Operational voltage	48 V AC/DC
Protection class	IP67
Wire cross-section	0.34 mm ²
Weight	See table below

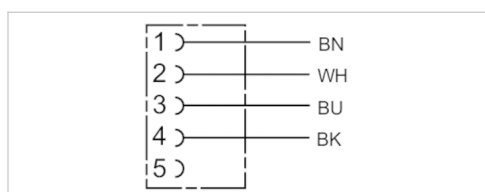

Technical data

Part No.	Max. current	Number of wires	Cable-Ø	Cable length	Weight
1834484256	4 A	4	5.2 mm	3 m	0.122 kg
1834484257	4 A	4	5.2 mm	5 m	0.194 kg
1834484258	4 A	4	5.2 mm	10 m	0.373 kg

Technical information

The specified protection class is only valid in assembled and tested state.

Technical information

Material	
Cable sheath	Polyurethane

Dimensions

Dimensions

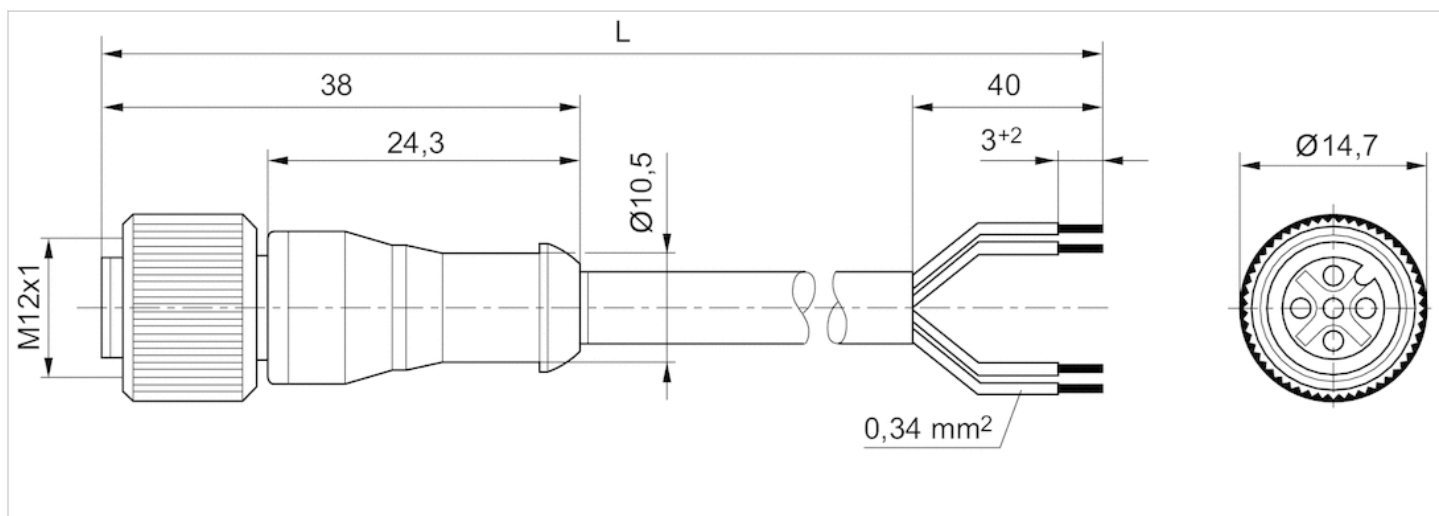

L = length

Pin assignments

Pin assignment, socket

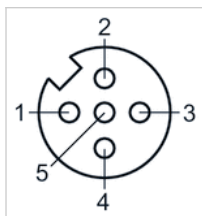

- (1) BN=brown
- (2) WH=white
- (3) BU=blue
- (4) BK=black
- (5) not assigned

Round plug connector, Series CON-RD

- Socket, M12x1, 4-pin, A-coded, straight, 180°
- UL (Underwriters Laboratories)
- unshielded



Connection type	Screws
Ambient temperature min./max.	-40 ... 85 °C
Operational voltage	48 V AC/DC
Protection class	IP67
Weight	0.015 kg

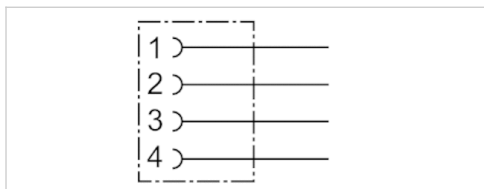

Technical data

Part No.	Max. current	suitable cable-Ø min./max
1834484177	4 A	4 / 6 mm

Technical information

Material	
Housing	Polyamide

Dimensions

Dimensions

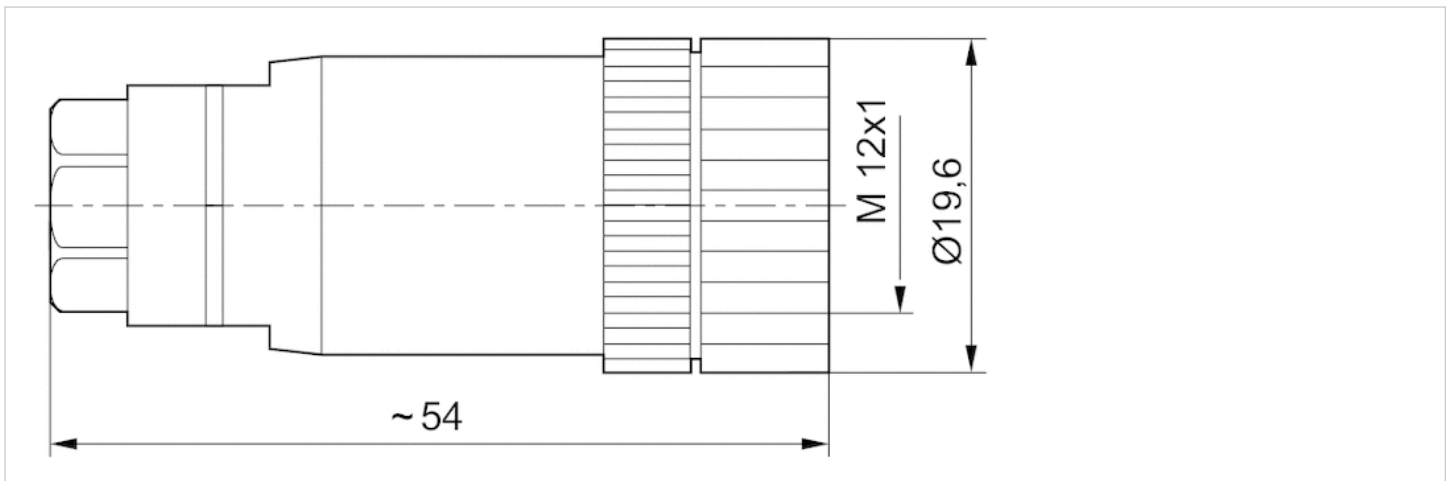

Pin assignments

Pin assignment, socket

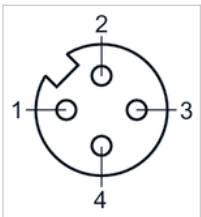

Round plug connector, Series CON-RD

- Socket, M12x1, 4-pin, A-coded, angled, 90°
- unshielded



Connection type	Screws
Ambient temperature min./max.	-40 ... 85 °C
Operational voltage	48 V AC/DC
Protection class	IP67
Weight	0.016 kg

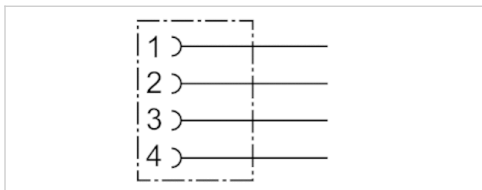

Technical data

Part No.	Max. current	suitable cable-Ø min./max
1834484178	4 A	4 mm

Technical information

The specified protection class is only valid in assembled and tested state.

Technical information

Material	
Housing	Polyamide

Dimensions

Dimensions

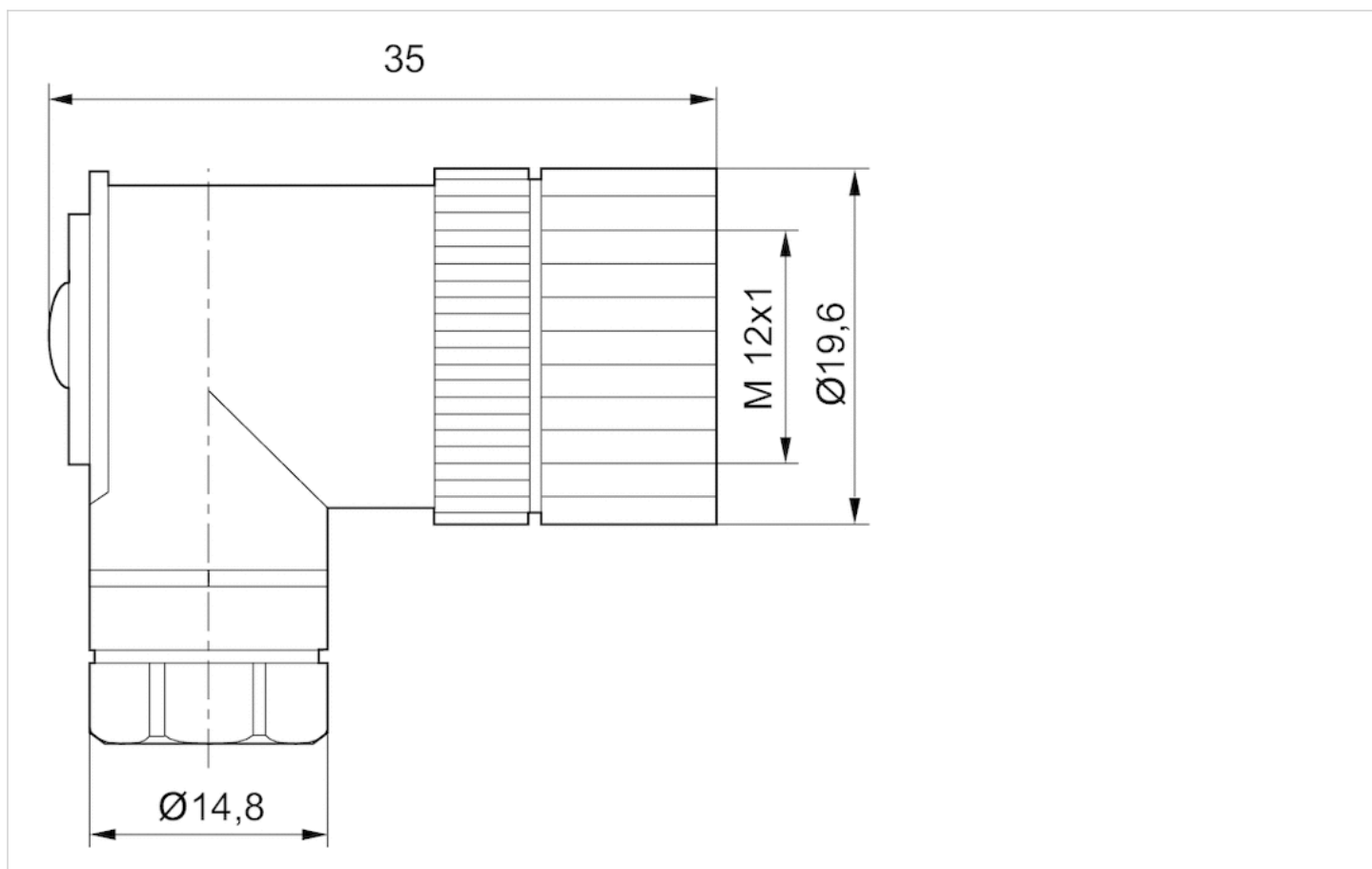

Pin assignments

Pin assignment, socket

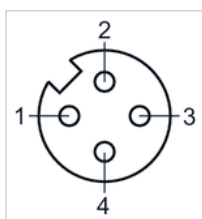

Adapter, Series CON-VP

- Socket, form C, 2+E, angled, 90°
- Plug, M12x1, 3-pin, A-coded, straight, 180°
- unshielded
- with LED Yellow



Ambient temperature min./max.	-10 ... 0 °C
Operational voltage	24 V DC
Protection class	IP65
Protective circuit	Varistor
Mounting screw tightening torque	0.6 Nm
Weight	0.013 kg

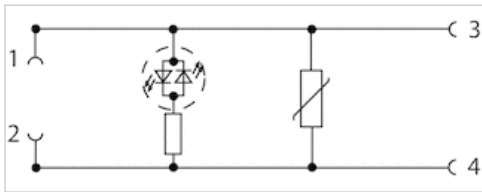

Technical data

Part No.	Max. current	Protective circuit	Contact assignment	LED status display
R412009553	1 A	Varistor	2+E	Yellow

Technical information

Material	
Housing	Polyurethane

Dimensions

Dimensions

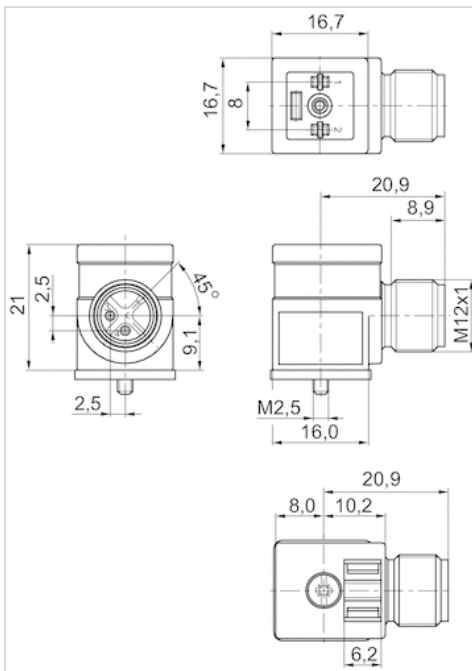

Transition plate, Series AS1, AS2, AS3, AS5

- Adapter plate for assembling a series DO30 pilot valve with CNOMO porting configuration on a 3/2-way shut-off valve without pilot



Weight

0.025 kg

Technical data

Part No.

R412006360

Scope of delivery incl. 4 mounting screws, 2 O-rings

Technical information

Adapter plate for assembling a series DO30 pilot valve with CNOMO porting configuration on a 3/2-way shut-off valve without pilot

Technical information

Material

Material

Aluminum

Dimensions

Dimensions in mm

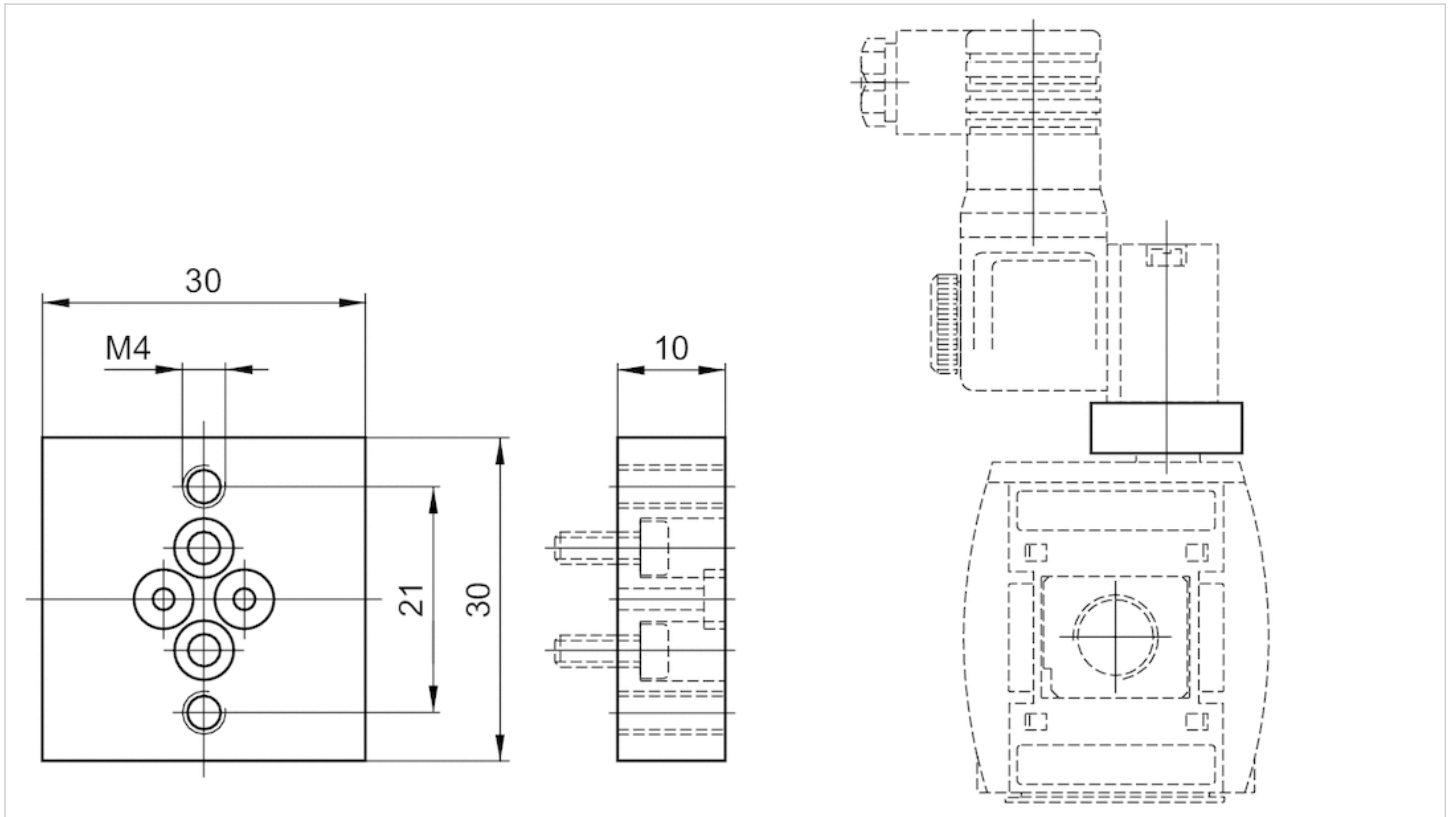

Adapter

- Adapter for connecting the control pressure to a AS series 3/2 directional shut-off valve without pilot control to realize pneumatic actuation, G 1/8
- G 1/8
- AS1 AS2 AS3 AS5



Weight

0.019 kg

Technical data

Part No.	Port G
R412006359	G 1/8

Delivery incl. 2 mounting screws M3x20, Flat gasket

Technical information

Material	
Material	Aluminum

Dimensions

Dimensions in mm

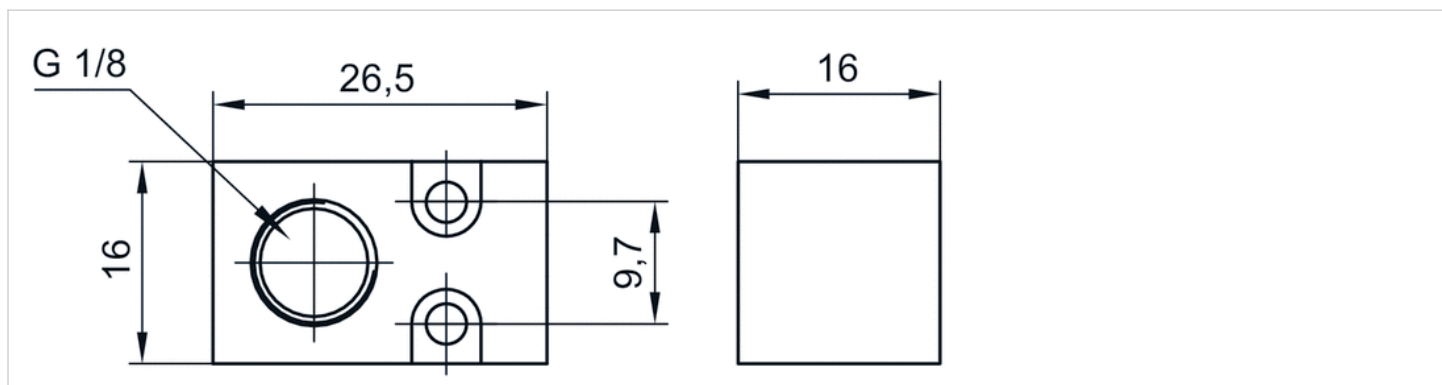

Adapter for external pilot air



Ambient temperature min./max.

50 °C

Weight

0.015 kg

Technical data

Part No.

R412025904

Delivery incl. 1 seal plate, 1 screw 3x10, 1 screw DIN 84-M3x18

Dimensions

Dimensions in mm

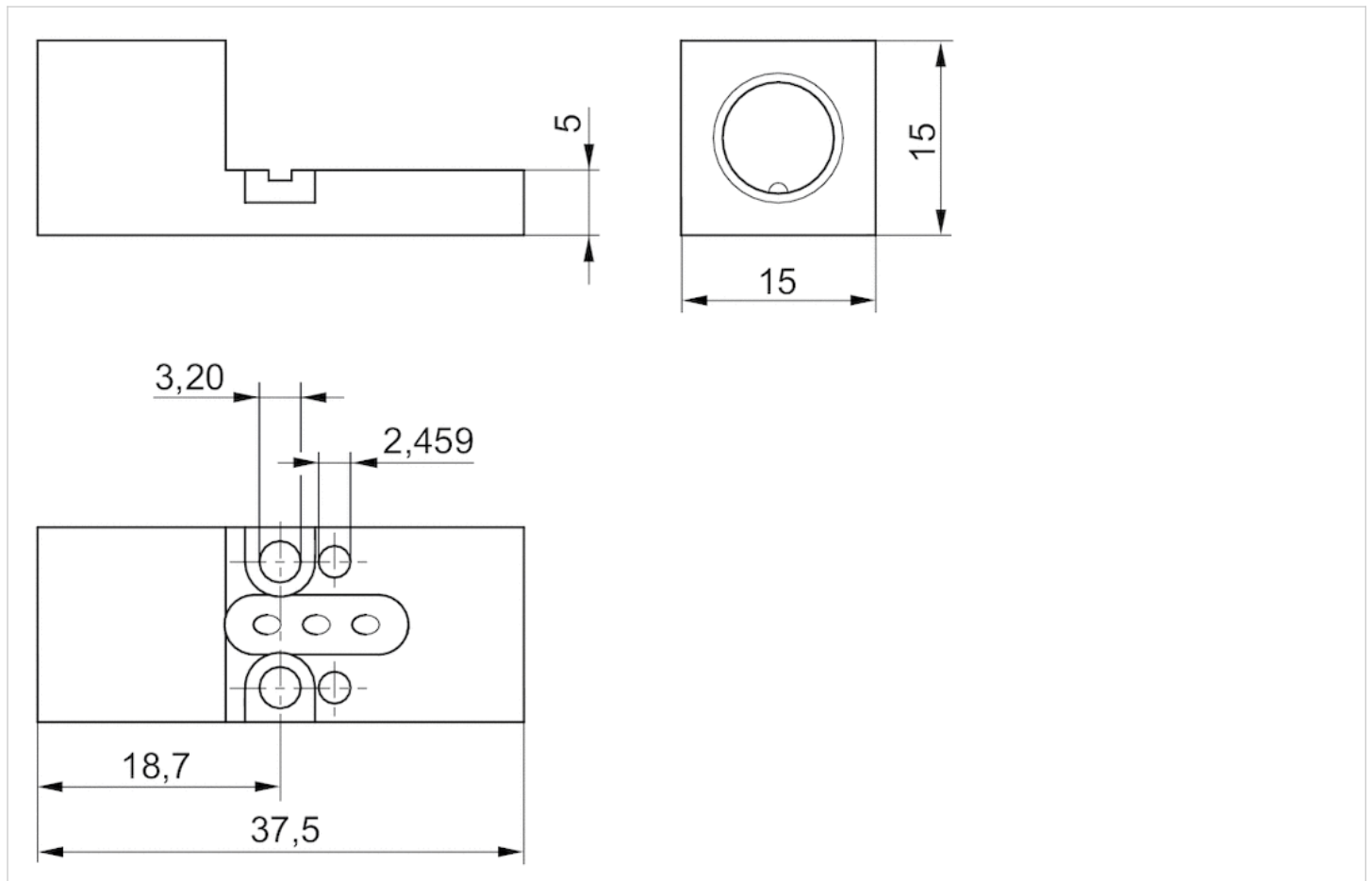

Mounting aid

- Assembly aid for permanent actuation of manual override ("press") on pilot valve DO16 with electrical push-in fitting, form C.



Technical data

Part No.
R412019278

Scope of delivery incl. 1 mounting screw, 1 O-ring

Technical information

Material	
Housing	Aluminum

Dimensions

Dimensions in mm

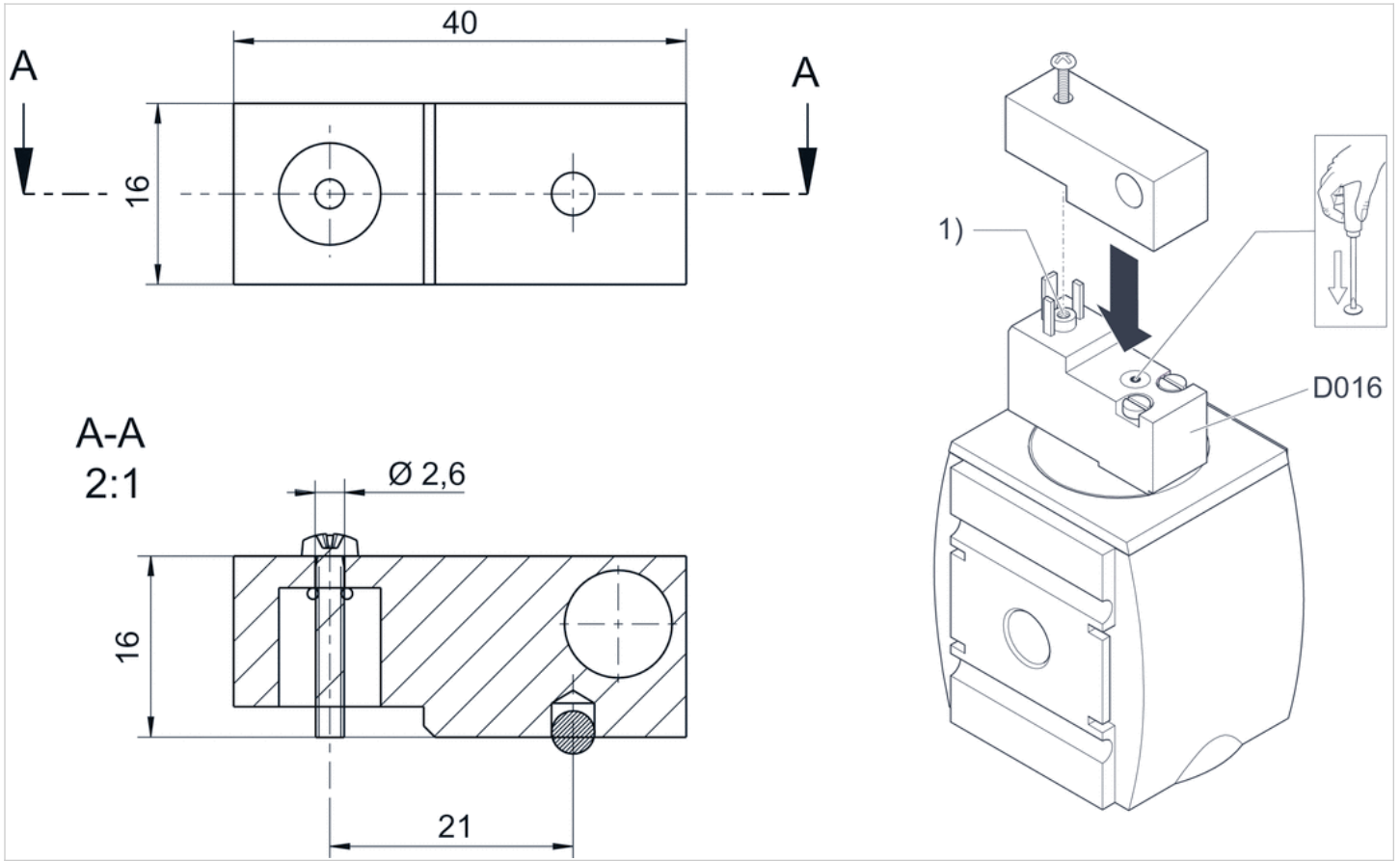

1) ISO 15217, form C

Mounting aid

- Assembly aid for permanent actuation of manual override ("press") on pilot valve DO16 with electrical connection M12x1.



Weight

0.023 kg

Technical data

Part No.

R412015193

Technical information

Mounting the assembly aid to the pilot valve using valve plug connector M12x1

Technical information

Material

Housing

Aluminum

Dimensions

Dimensions in mm

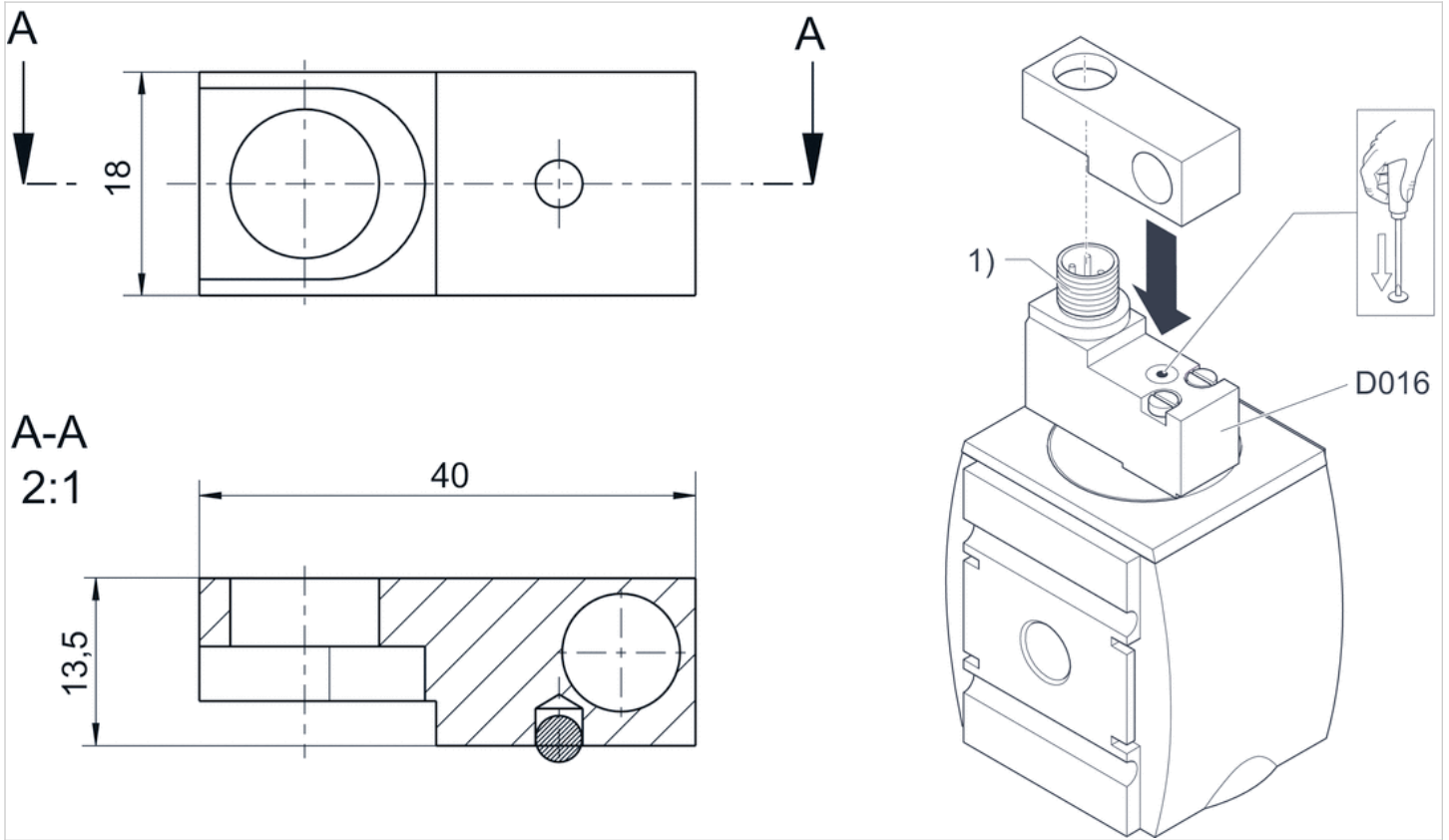

1) M12x1

mortise lock

- for AS2 AS3 AS5



Technical data

Part No.	Type
R412007959	Standard locking, with key
R412006374	E11 locking, without key

Technical information

Material	
Housing	Steel

Dimensions

Dimensions in mm

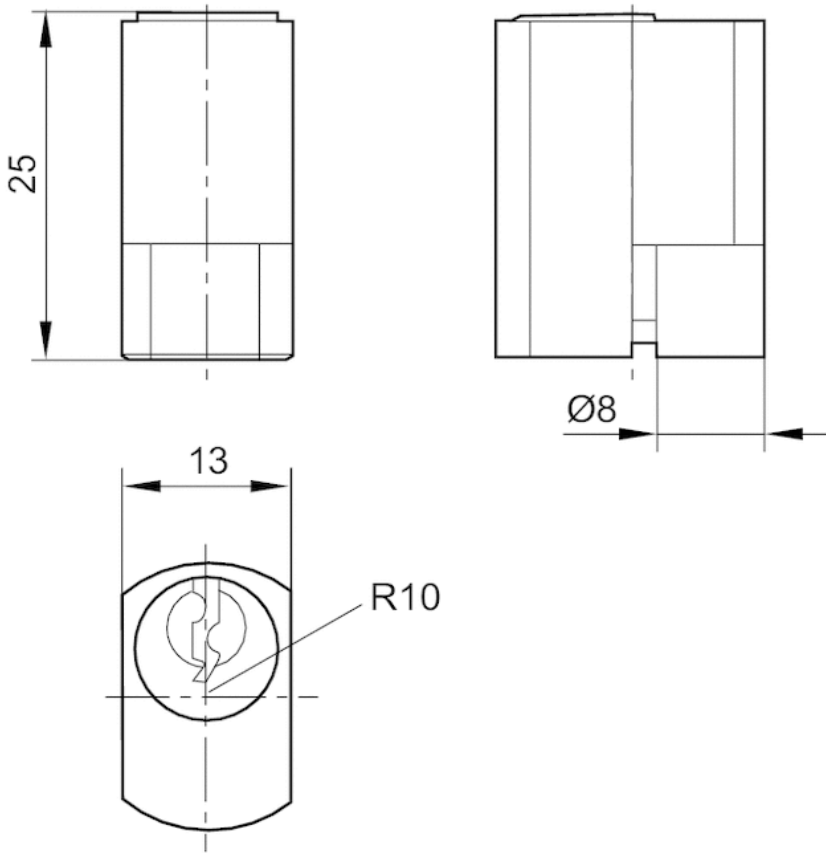

Application example

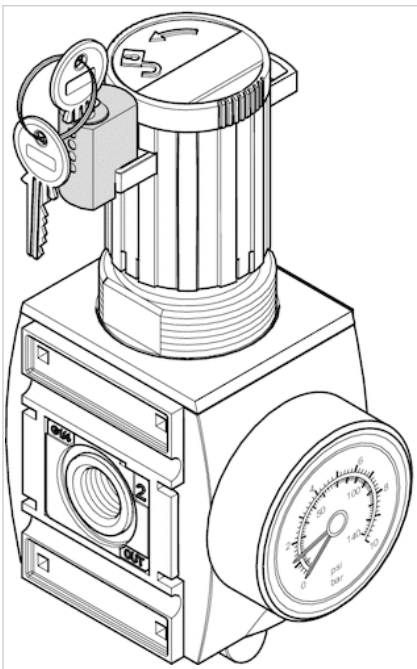

Key for E11 locking



Technical data

Part No.	Delivery unit
R961403407	1 piece

Dimensions

Dimensions in mm

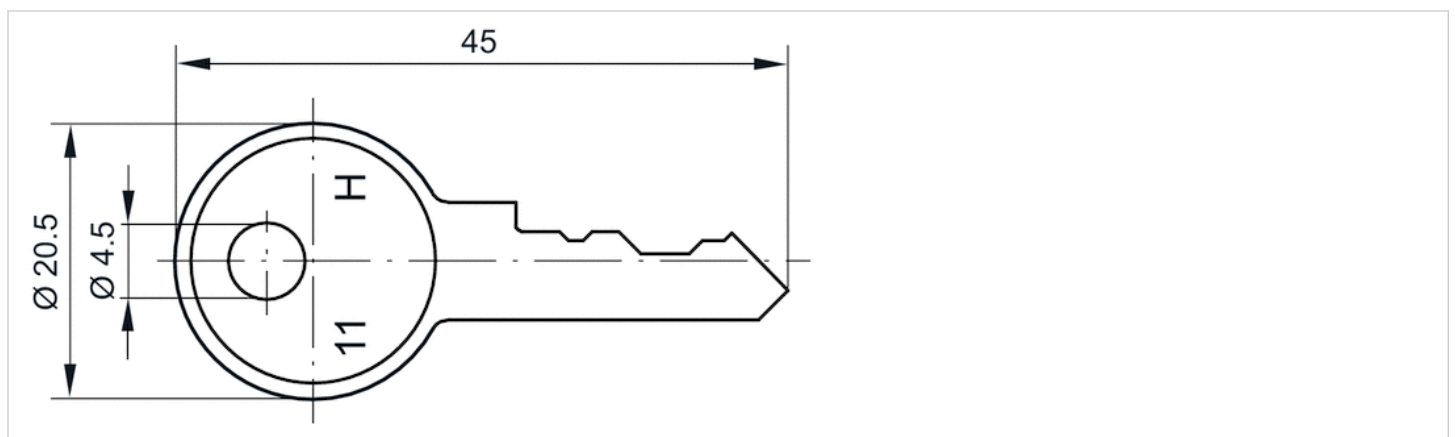

Pressure sensor, Series PE5

- Operating pressure -1 ... 0 -1 ... 1 0 ... 6 0 ... 10 0 ... 12 bar
- electronic
- Output signal analog 0 - 10 V DC, 4 - 20 mA
- Output signal digital 2 x PNP, NPN, Push-pull PNP, NPN, Push-pull PNP, NPN, push-pull, 1x IO-Link
- Electr. connection Plug M12x1 4-pin
- Compressed air connection Internal thread G 1/4



Type	electronic
Certificates	CE declaration of conformity cULus RoHS Conforms with REACH Free of substances that impair surface wetting in the coating process
Compressed air connection	Internal thread G 1/4
Ambient temperature min./max.	0 ... 60 °C
Medium temperature min./max.	0 ... 60 °C
Medium	Compressed air (max. 40 µm)
Max. oil content of compressed air	40 mg/m ³
Measurement	Relative pressure
Display	LCD display, 4 digits Color setting: green or red
Units displayed	bar, psi, kPa, MPa, inHg
Switching logic	NO/NC (adjustable)
Shock resistance max.	30 g
Vibration resistance	5 g (10 - 150 Hz)
Precision (% of full scale value)	±1.5% in temperature range of 10 - 30°C ± 2 % including temperature drift
Repeatability (% of full scale value)	± 0,2 %
Switching time	5 ms
Switching point	adjustable 0 ... 100%
Resetting point	adjustable 0 ... 100%
Hysteresis	adjustable
Delayed hysteresis	adjustable
Window function	adjustable
DC operating voltage min./max.	17 ... 30 V DC
Analog output	0 - 10 V DC, 4 - 20 mA
Quiescent current consumption	40 mA
Analog output linearity	± 0.5% of the final value
Maximum load (analog current output)	600 Ω
Short circuit resistance	Max. 600 ohms (current output) Min. 3K ohms (voltage output)
Mounting types	Directly on hat rail and wall mounting For panel installation using mounting kit via double nipple
Protection class	IP65, IP67 with connections assembled
Electr. connection	Plug M12x1 4-pin
Weight	0.04 kg

Technical data

Part No.		Operating pressure range	Protection against overpressure
		min./max.	
R412010761		-1 ... 0 bar	5 bar
R412010769		-1 ... 0 bar	5 bar
R412010775		-1 ... 0 bar	5 bar
R412010763		-1 ... 1 bar	5 bar
R412010771		0 ... 6 bar	15 bar
R412010765		0 ... 6 bar	15 bar
R412010777		0 ... 6 bar	15 bar
R412010773		0 ... 10 bar	15 bar
R412010767		0 ... 10 bar	15 bar
R412010779		0 ... 10 bar	15 bar
R412010782		0 ... 12 bar	16 bar
R412010806		0 ... 12 bar	16 bar

Part No.	Output signal	Output signal	Fig.	
	Analog	digital		
R412010761	-	2 x PNP, NPN, Push-pull	Fig. 1	-
R412010769	0 - 10 V DC-4 ... 20 mA	PNP, NPN, Push-pull	Fig. 1	-
R412010775	-	PNP, NPN, push-pull, 1x IO-Link	Fig. 1	1)
R412010763	-	2 x PNP, NPN, Push-pull	Fig. 1	-
R412010771	0 - 10 V DC-4 ... 20 mA	PNP, NPN, Push-pull	Fig. 1	-
R412010765	-	2 x PNP, NPN, Push-pull	Fig. 1	-
R412010777	-	PNP, NPN, push-pull, 1x IO-Link	Fig. 1	1)
R412010773	0 - 10 V DC-4 ... 20 mA	PNP, NPN, Push-pull	Fig. 1	-
R412010767	-	2 x PNP, NPN, Push-pull	Fig. 1	-
R412010779	-	PNP, NPN, push-pull, 1x IO-Link	Fig. 1	1)
R412010782	-	2 x PNP, NPN, Push-pull	Fig. 1	-
R412010806	-	PNP, NPN, push-pull, 1x IO-Link	Fig. 1	1)

1) The IO-Link device description (IODD) for the PE5 pressure sensor is available for download in the Media Centre.

Technical information

Alternative pressure connection (G1/4) on the rear side (closed with plug)

Display color selectable, red or green

Technical information

Material	
Housing	Polycarbonate
Seals	Acrylonitrile butadiene rubber
Blanking plug	Polyoxymethylene
Electr. connection	Aluminum, black anodized

Dimensions

Fig. 1

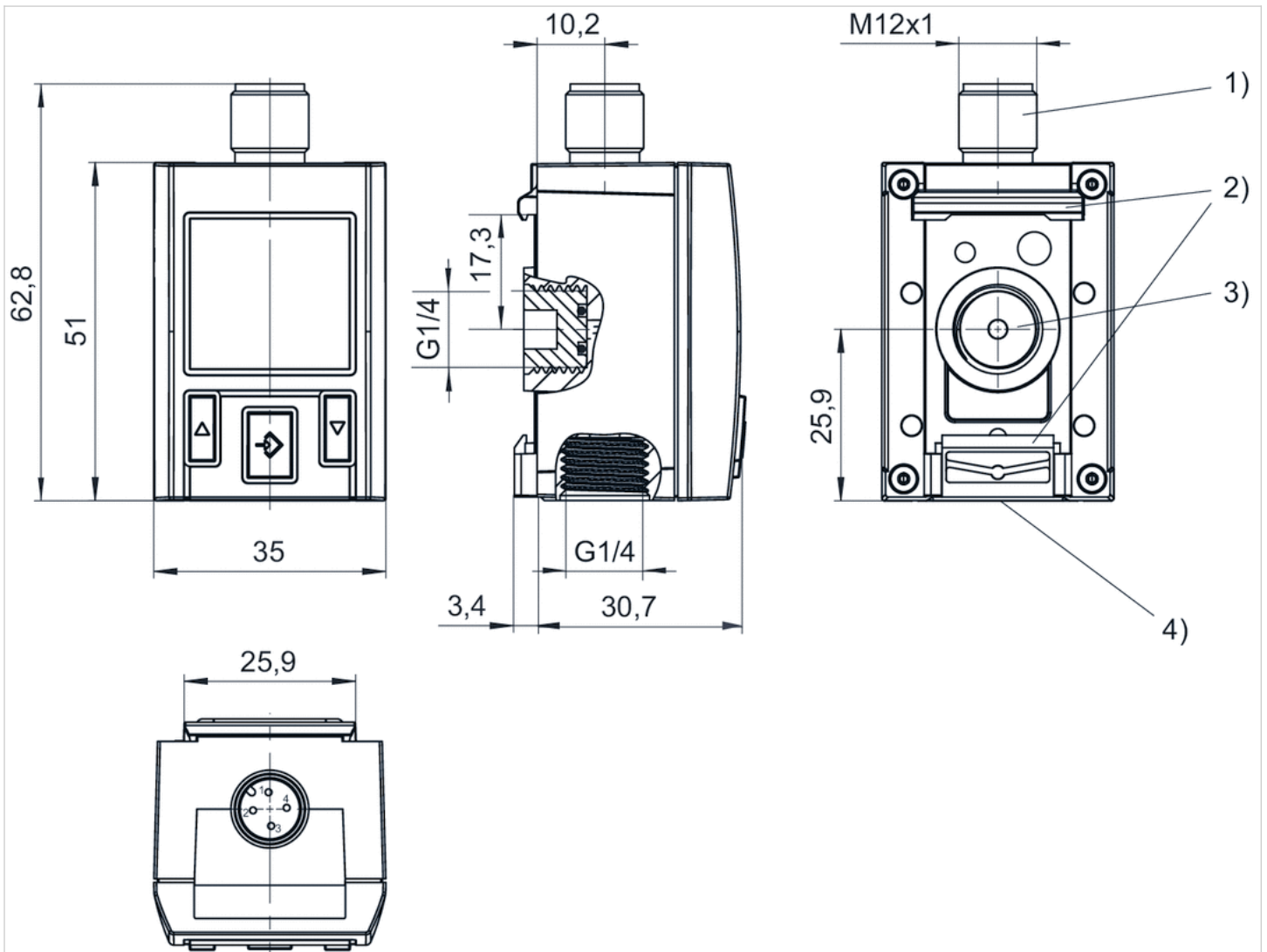

- 1) M12x1 electrical connection
- 2) Mounting for hat rail and wall mounting
- 3) Alternative pressure connection (G1/4) closed with plug
- 4) Pressure connection G1/4

Fig. 2

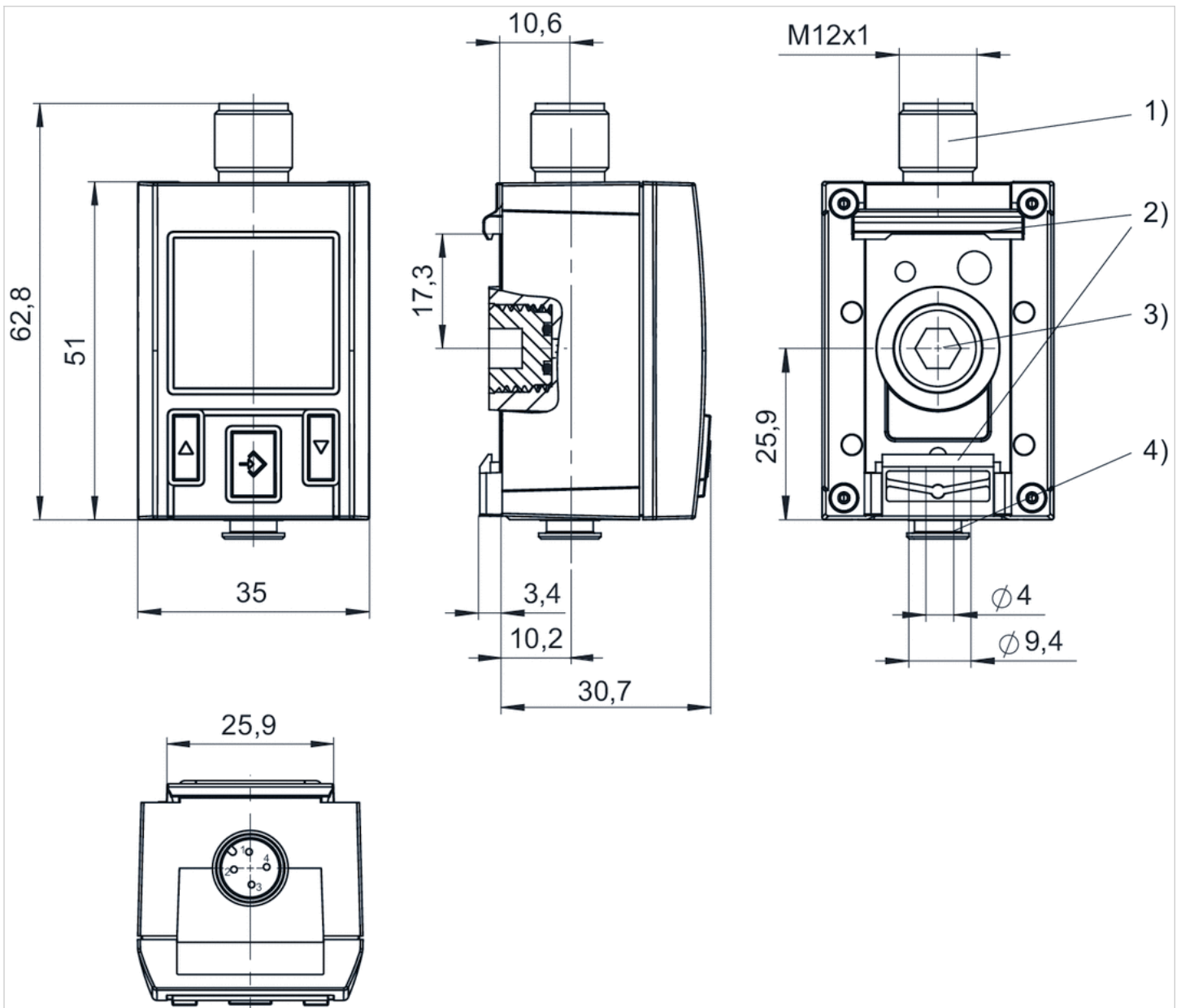

- 1) M12x1 electrical connection
- 2) Mounting for hat rail and wall mounting
- 3) Alternative pressure connection (G1/4) closed with plug
- 4) Pressure connection, tubing Ø 4 mm

Fig. 3, Electr. connection for leak test

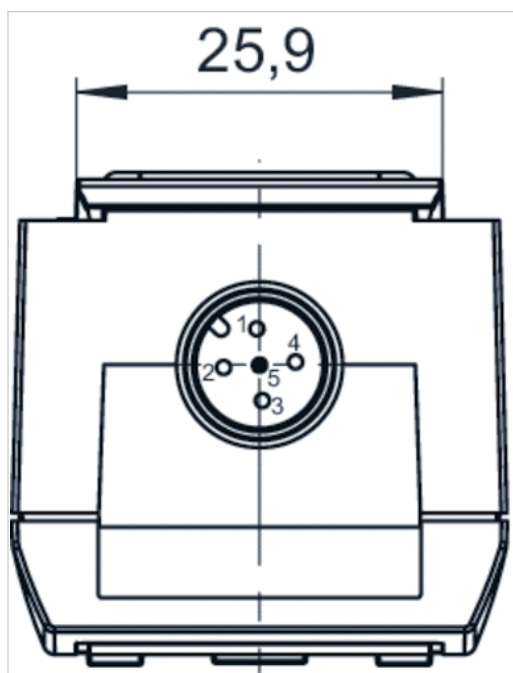

Display and operation area

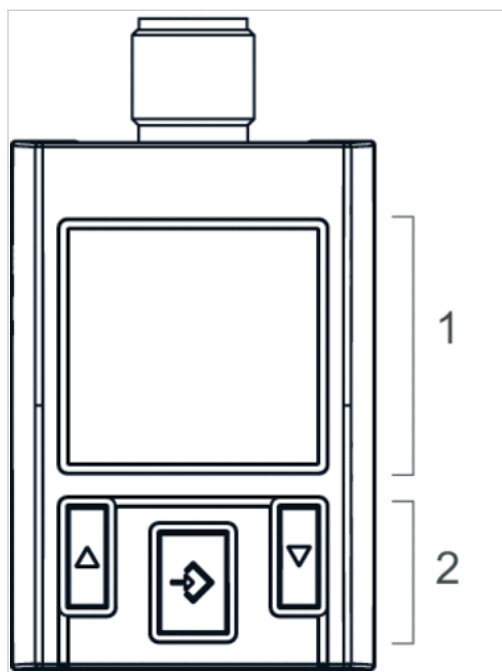

- 1) LCD display
- 2) Control panel with 3 buttons

Diagrams

Operating mode, PNP

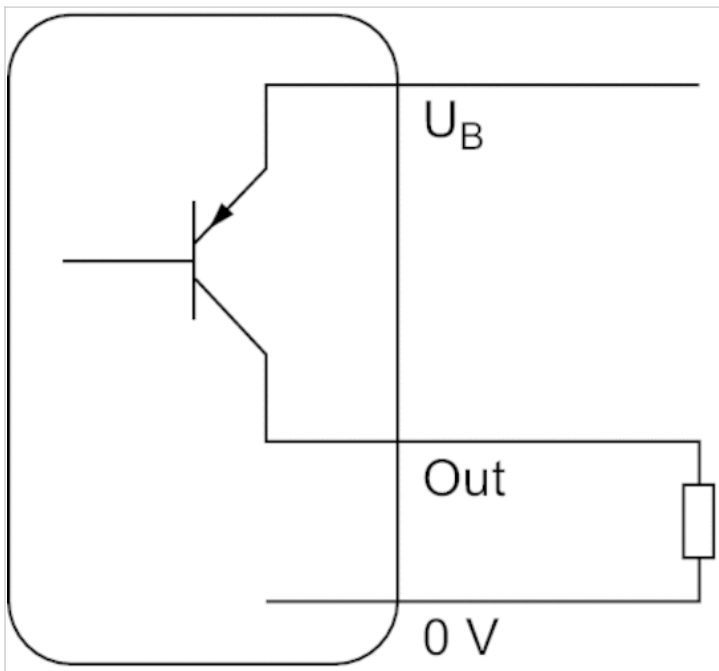

Operating mode, NPN

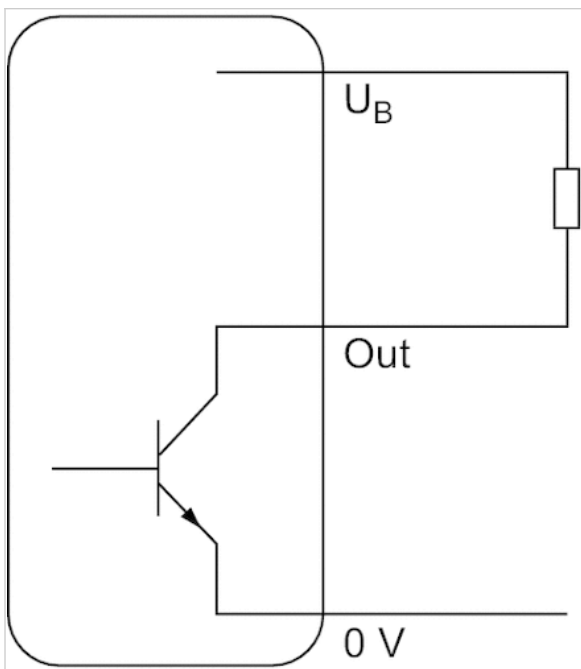

Operating mode, Push-pull

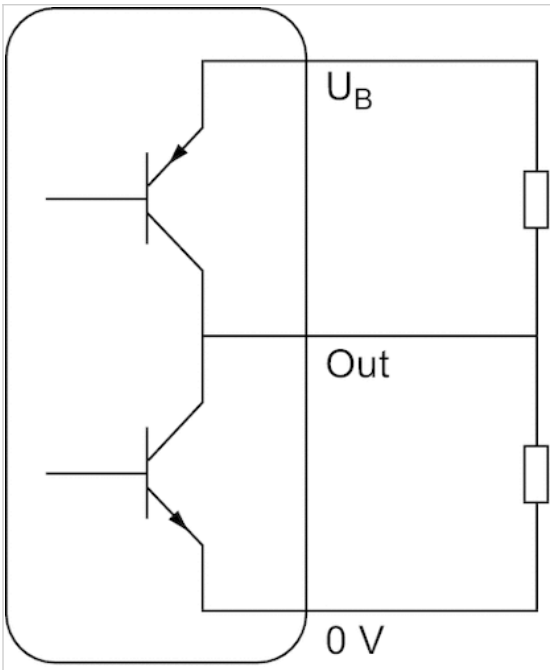

Hysteresis function: switching and resetting behavior dependent on pressure p and time t, in case of overpressure

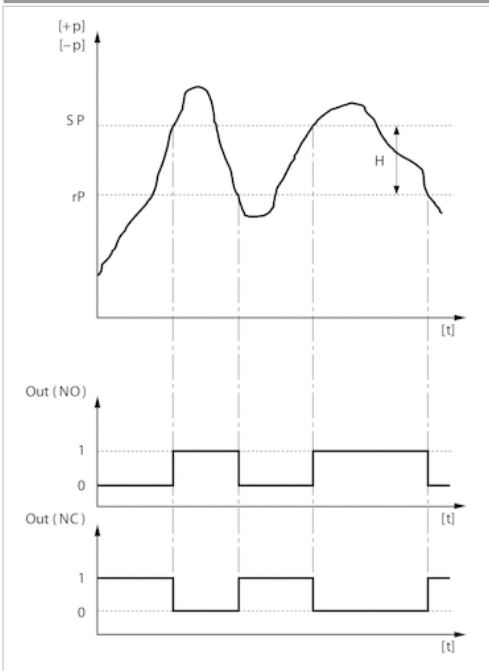

- H: Hysteresis
- SP = switching point
- RP = resetting point
- Out (NC): switch output, break contact
- Out (NO): switch output, make contact

Hysteresis function: switching and resetting behavior dependent on pressure p and time t , in case of underpressure

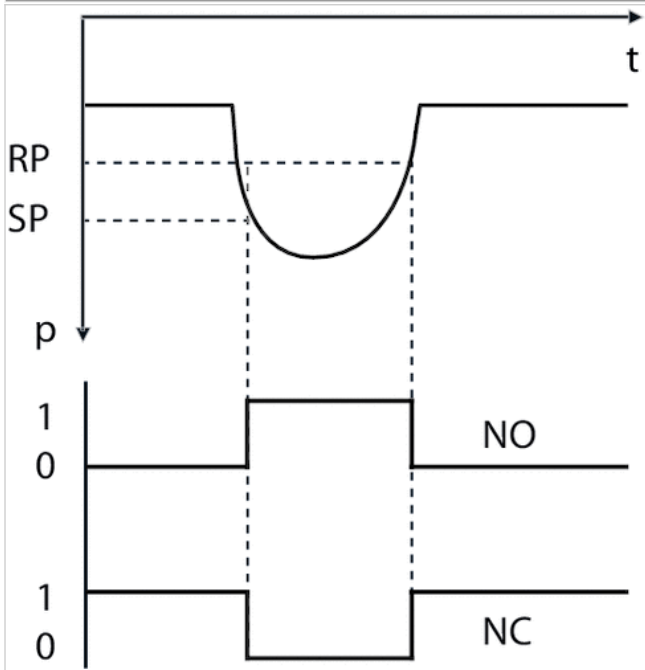

Delayed hysteresis function: switching and resetting behavior depending on pressure p and time t

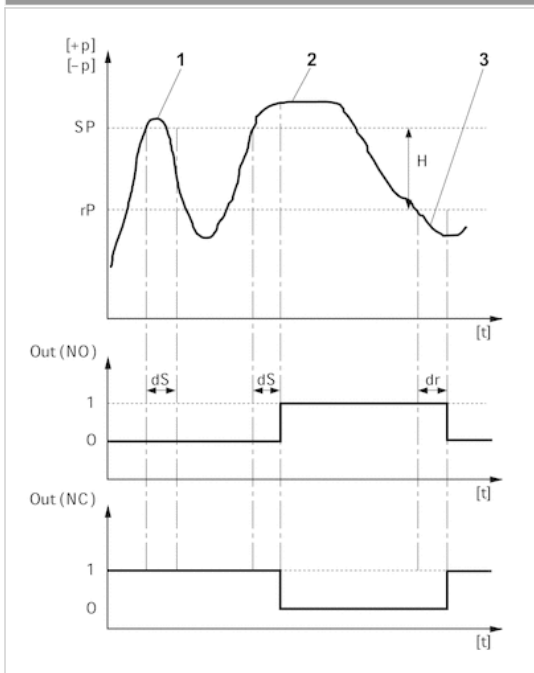

H: Hysteresis

SP = switching point

RP = resetting point

Out (NC): switch output, break contact

Out (NO): switch output, make contact

dS: switching delay

dR = reset delay

1) period of pressure over the switching point dS : pressure sensor does not switch

2) Period of pressure over the switching point $> dS$: pressure sensor switches

3) Period of pressure under the resetting point $> dR$: pressure sensor switches

Window function: switching and resetting behavior depending on pressure p and time t

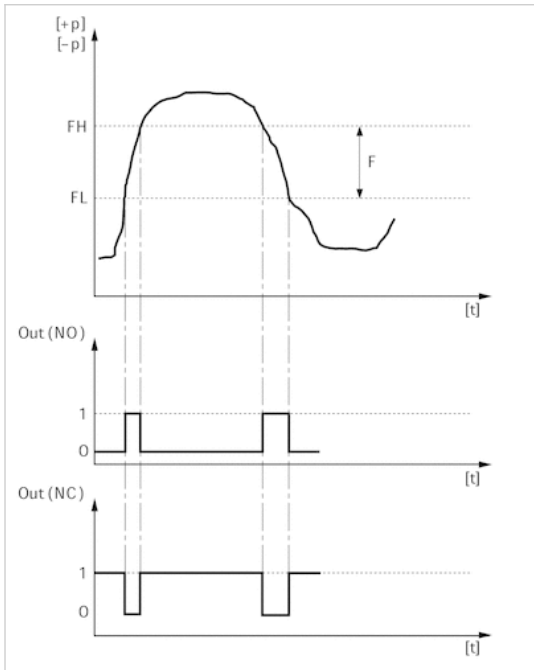

FH: pressure band, upper value
 FL: pressure band, lower value
 Out (NC): switch output, break contact
 Out (NO): switch output, make contact

Leakage characteristic

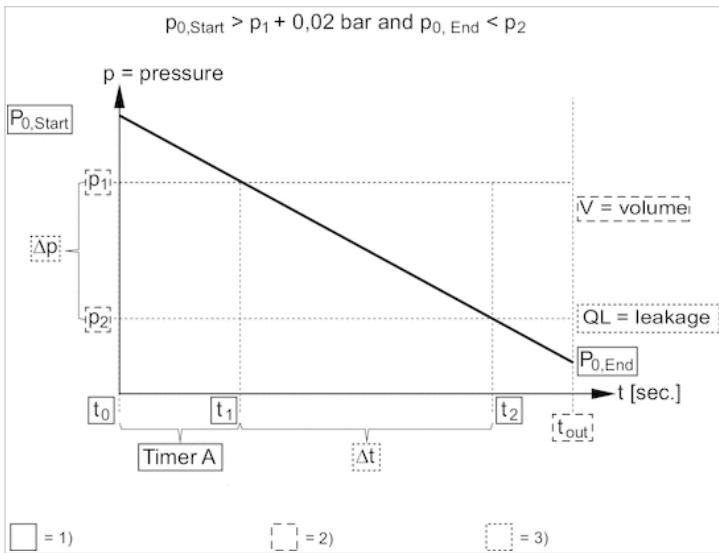

- 1) Internally stored parameter
- 2) Adjustable parameter
- 3) Output value

Circuit diagram

Block diagram, 1x PNP and 1x analog

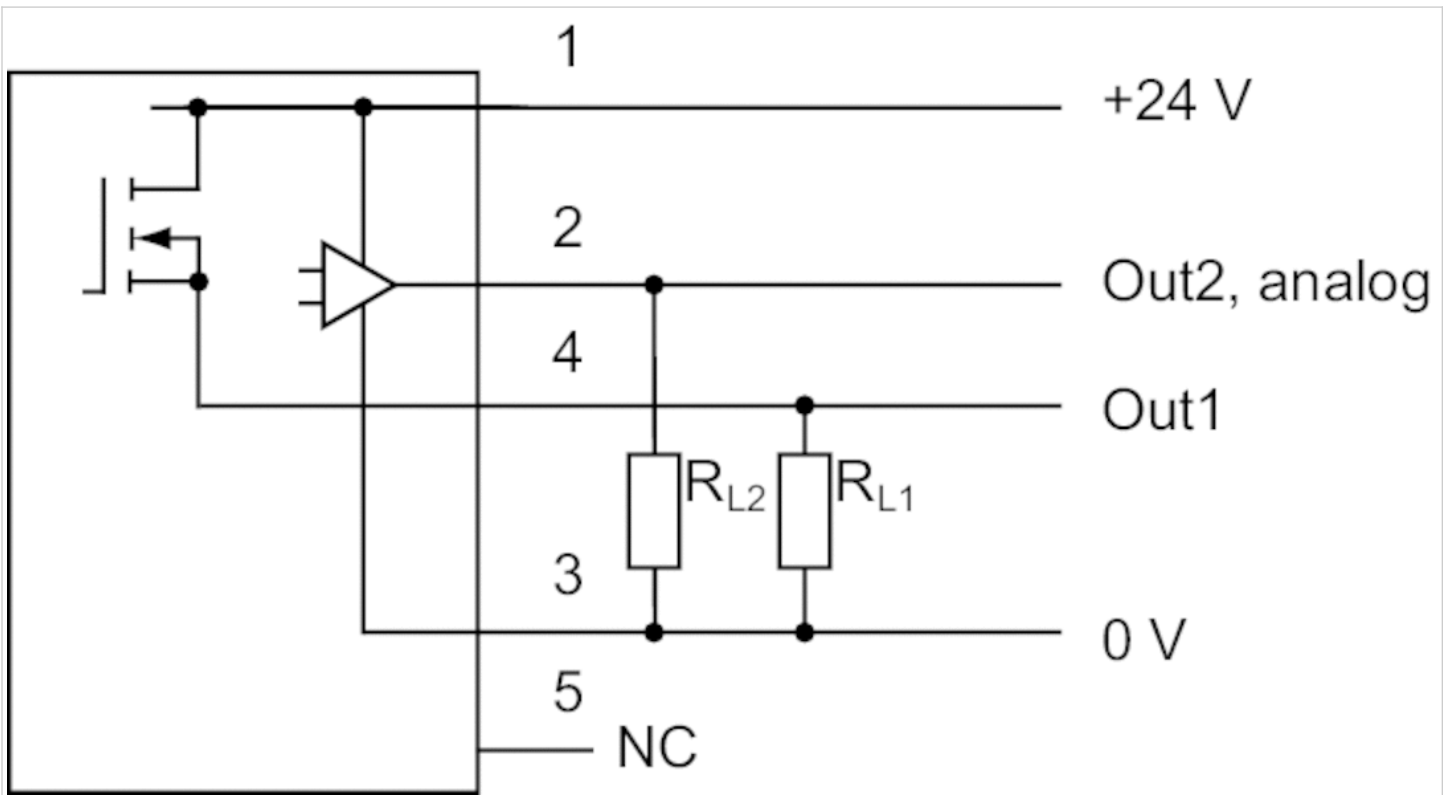

RL = storable position

Block diagram, 1x NPN and 1x analog

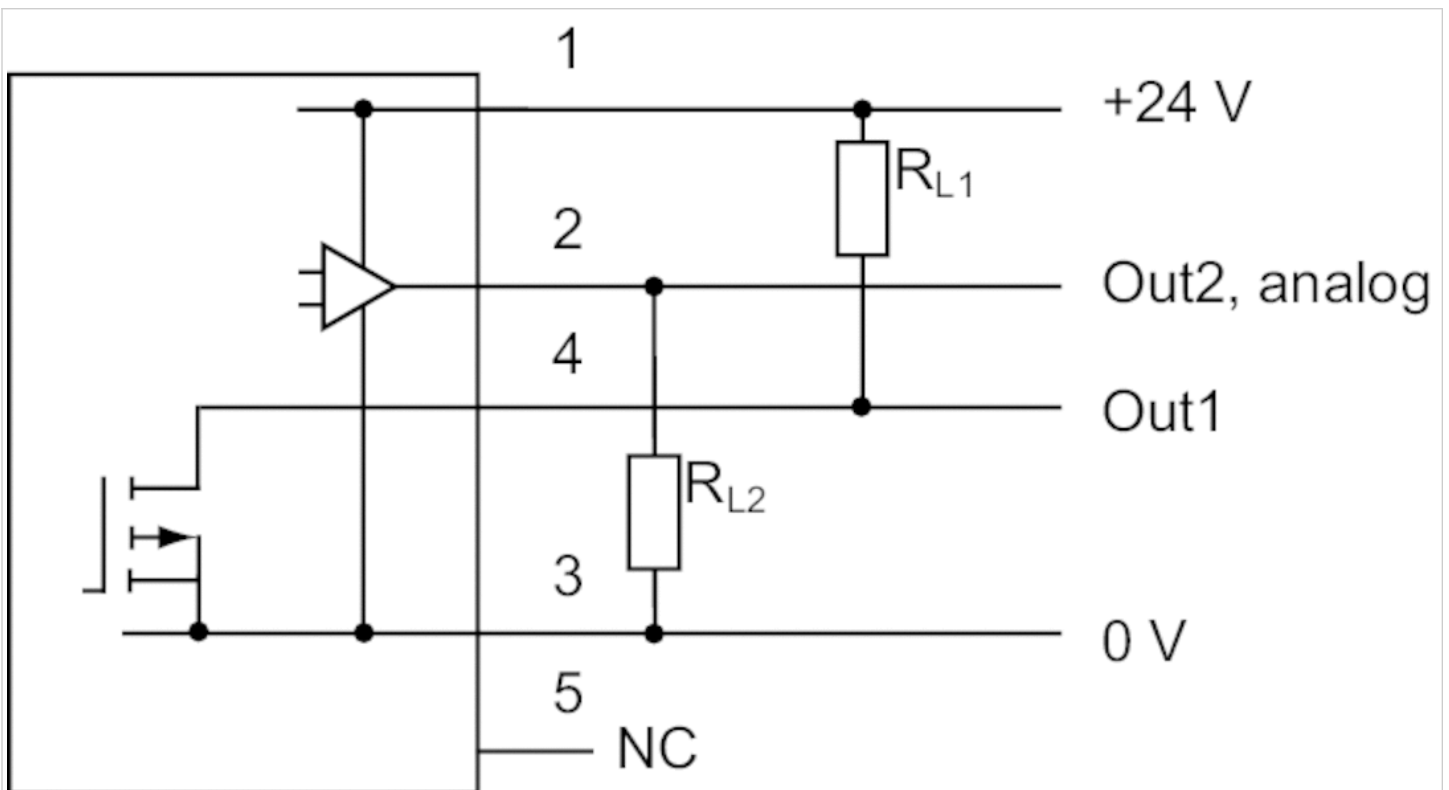

RL = storable position

Pin assignments

Pin assignments, M12x1, 4-pin

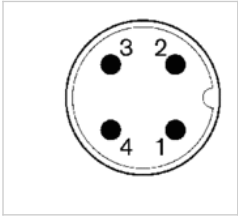

Pin	1
Allocation	operational voltage + UB
	2
	3
	switch output Out2, analog: A or V, digital: PNP, NPN, push-pull
	0 V
	4
	switch output Out1, digital: PNP, NPN, push-pull

Pin assignments

Pin assignments, M12x1, 5-pin

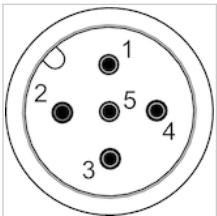

Pin	1	2	3
Allocation	Supply Voltage	Switch output PNP/NPN/push-pull, switchable	0 V
		4	
		Switch output PNP/NPN/push-pull/leakage mode, digital switch input PNP	
		5	
		Analog output (0 to 10 V DC, 4 to 20 mA)	











Pressure sensor, Series PE2

- Operating pressure -1 ... 1 0 ... 16 bar
- electronic
- Output signal analog 1 x PNP, 1 x analog 4-20 mA
- Electr. connection Plug M12x1 5-pin
- Compressed air connection Internal thread G 1/4 Flange with O-ring Ø 5x1,5



Type	electronic
Function	1 x PNP, 2 x PNP 1x PNP and 1x analog
Mounting orientation	Any
Certificates	CE declaration of conformity EMV
Working pressure min./max.	See table below
Ambient temperature min./max.	-10 ... 75 °C
Medium temperature min./max.	-10 ... 75 °C
Medium	Compressed air Neutral gases
Measurement	Relative pressure
Display	OLED
Units displayed	bar, mbar, psi, kPa, MPa, %
Switching logic	Hysteresis function NO/NC (programmable) Window function NO/NC (programmable)
Operating pressure display	2 LED
Shock resistance max.	30 g
Vibration resistance	5 g (10 - 150 Hz)
Precision (% of full scale value)	± 1 % including temperature drift
Switching time	10 ms at loads 100 kΩ > 10 ms at loads > 100 kΩ
Switching point	Adjustable ≥ 0.5% ... 100% FS
Resetting point	Adjustable 0% FS to SP -0.5% FS (or +0.5% FS when SP 0)
Hysteresis	adjustable
Switching/reset delay	adjustable
DC operating voltage min./max.	15 ... 32 V DC
Analog output	1 x PNP, 1 x analog 4-20 mA
Quiescent current consumption	50 mA
Maximum load (analog current output)	600 Ω
Short circuit resistance	short circuit resistant
Mounting types	via through holes
Protection class	IP65
Electr. connection	Plug M12x1 5-pin
Weight	0.3 kg

Technical data

Part No.		Type	Operating pressure range
			min./max.
R412010848		PE2-P1-G014-V10-010-M012	-1 ... 1 bar
R412010849		PE2-P1-F001-V10-010-M012	-1 ... 1 bar
R412010853		PE2-P2-G014-V10-010-M012	-1 ... 1 bar
R412010856		PE2-PA-G014-V10-010-M012	-1 ... 1 bar
R412010850		PE2-P1-G014-000-160-M012	0 ... 16 bar
R412010851		PE2-P1-F001-000-160-M012	0 ... 16 bar
R412010854		PE2-P2-G014-000-160-M012	0 ... 16 bar
R412010855		PE2-P2-F001-000-160-M012	0 ... 16 bar
R412010857		PE2-PA-G014-000-160-M012	0 ... 16 bar
R412010858		PE2-PA-F001-000-160-M012	0 ... 16 bar

Part No.	Protection against overpressure	Output signal	Output signal	Compressed air connection
		Analog	digital	
R412010848	10 bar	-	1 x PNP	Internal thread, G 1/4
R412010849	10 bar	-	1 x PNP	Flange with O-ring, Ø 5x1,5
R412010853	10 bar	-	2 x PNP	Internal thread, G 1/4
R412010856	10 bar	4 ... 20 mA	1 x PNP	Internal thread, G 1/4
R412010850	40 bar	-	1 x PNP	Internal thread, G 1/4
R412010851	40 bar	-	1 x PNP	Flange with O-ring, Ø 5x1,5
R412010854	40 bar	-	2 x PNP	Internal thread, G 1/4
R412010855	40 bar	-	2 x PNP	Flange with O-ring, Ø 5x1,5
R412010857	40 bar	4 ... 20 mA	1 x PNP	Internal thread, G 1/4
R412010858	40 bar	4 ... 20 mA	1 x PNP	Flange with O-ring, Ø 5x1,5

Part No.	Fig.
R412010848	Fig. 1
R412010849	Fig. 2
R412010853	Fig. 1
R412010856	Fig. 1
R412010850	Fig. 1
R412010851	Fig. 2
R412010854	Fig. 1
R412010855	Fig. 2
R412010857	Fig. 1
R412010858	Fig. 2

Technical information

Menu navigation is based on the VDMA specification with an additional plain text menu.

Technical information

Material	
Housing	Aluminum, Vibration-ground
Seals	Fluorocaoutchouc
Electr. connection	Aluminum with polymer insert
flange connection	Nitrile butadiene rubber, Fluorocaoutchouc

Dimensions

Fig. 1

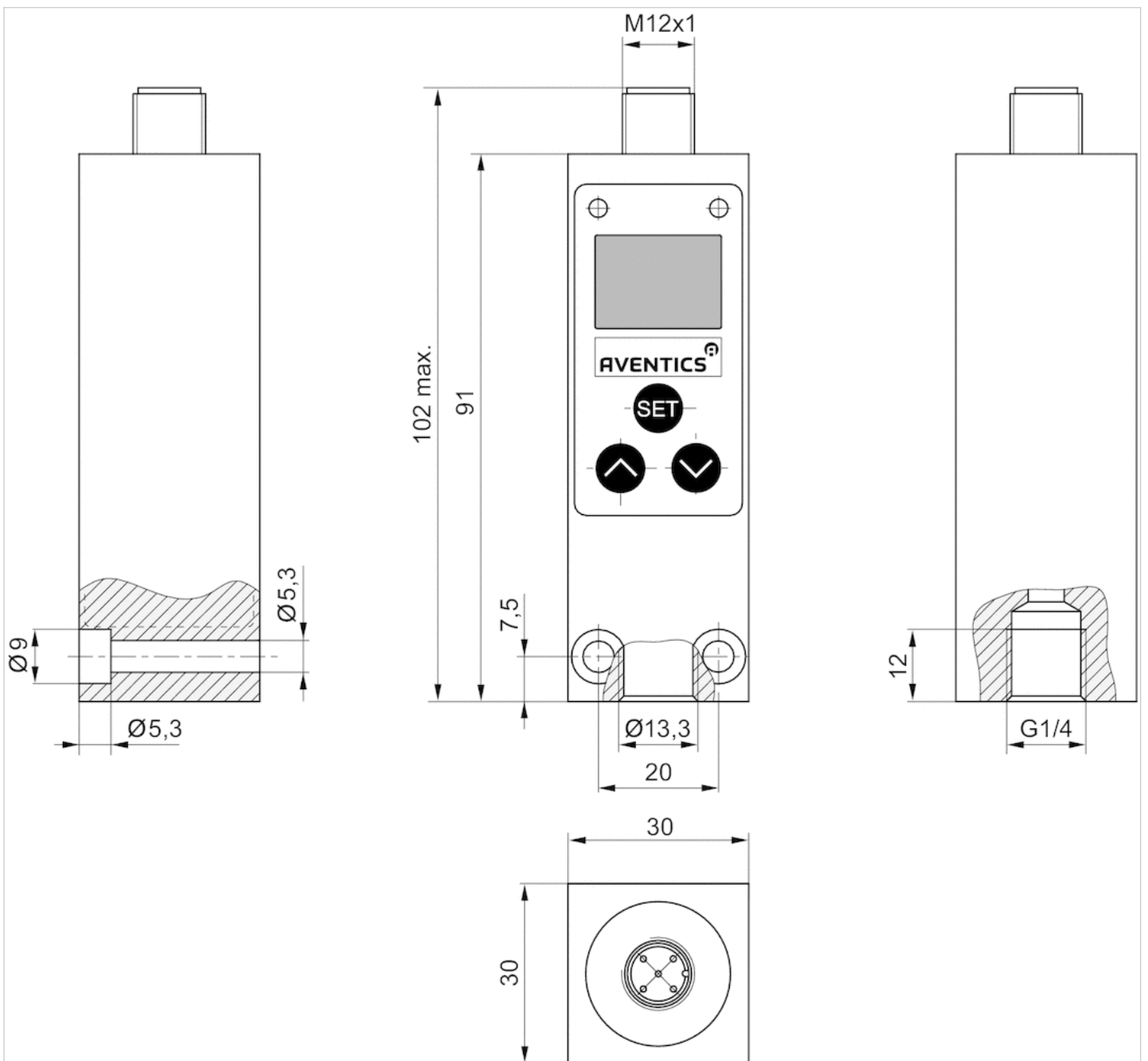
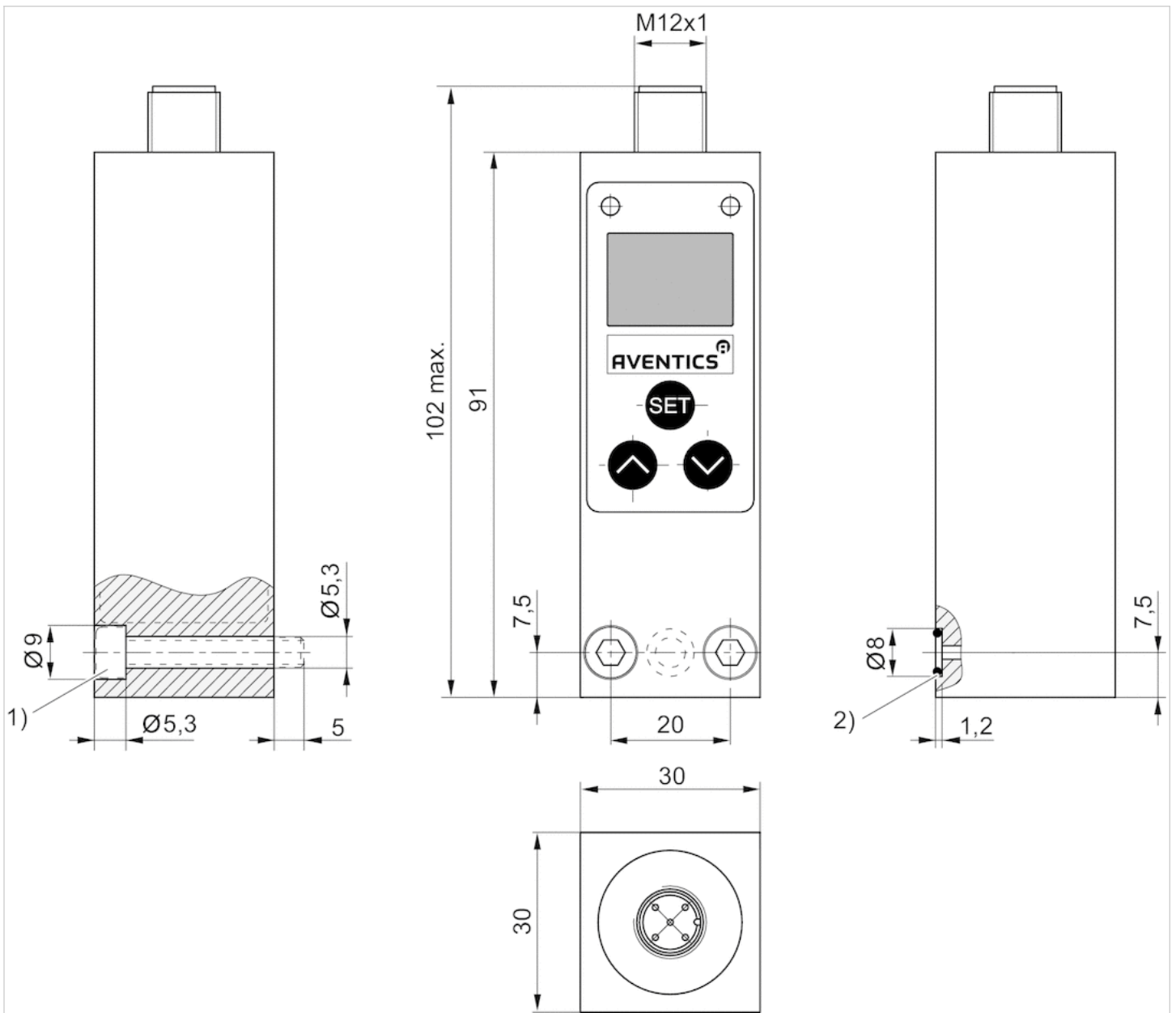
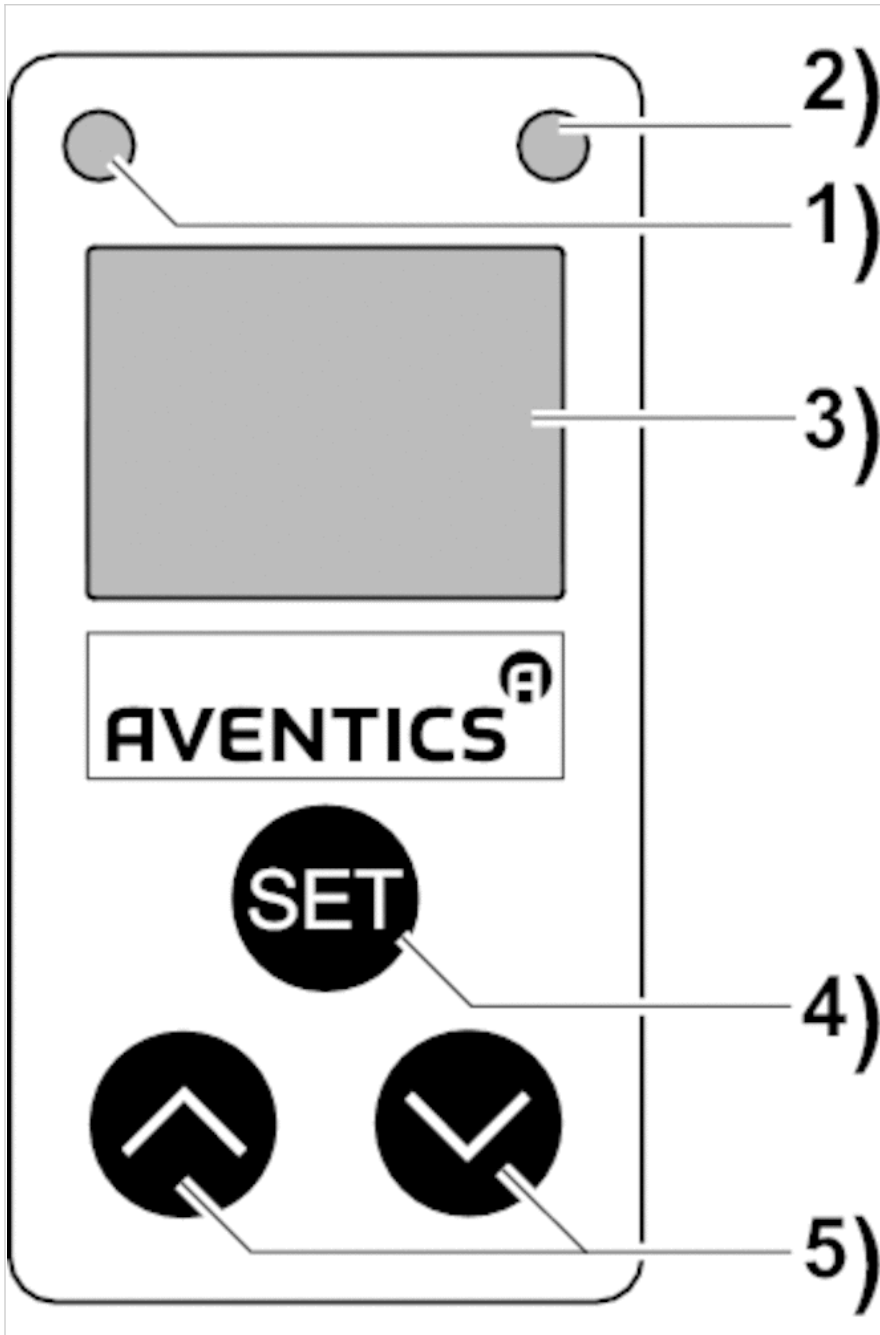

Fig. 2



- 1) cylinder screw M5x35 (included in scope of delivery)
- 2) O-ring $\varnothing 5 \times 1,5$ (included)

Display and operation area



- 1) LED for switch output 1
- 2) LED for switch output 2
- 3) Display (pressure, operating modes, navigation)
- 4) Confirm menu/menu item selection
- 5) Button for menu item/parameter change selection

Diagrams

Pressure-voltage characteristics curve

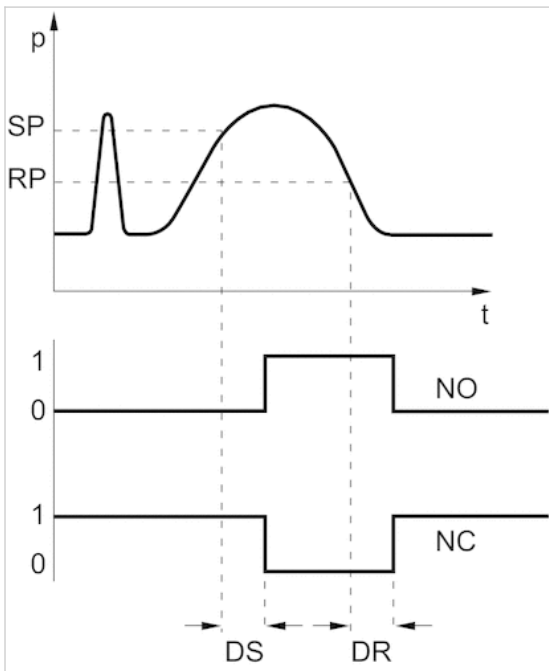

- SP = switching point
- RP = resetting point
- NO = Switching function open
- NC = Switching function closed without current
- DS = Delay for the switching point
- DR = Delay for the resetting point

Circuit diagram

Block diagram, 1 x PNP

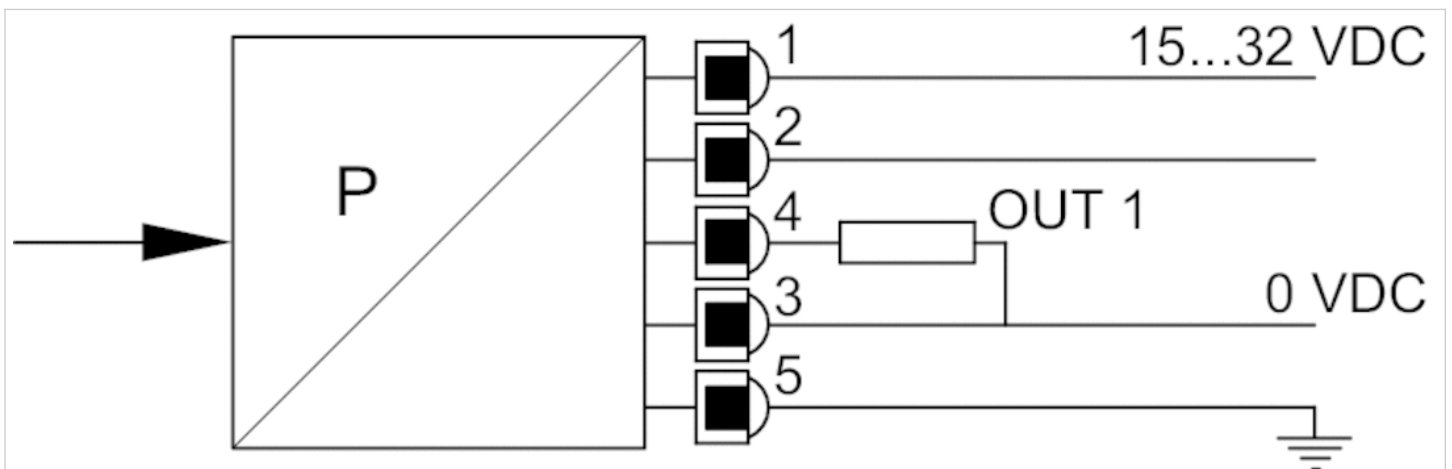

Block diagram, 2 x PNP

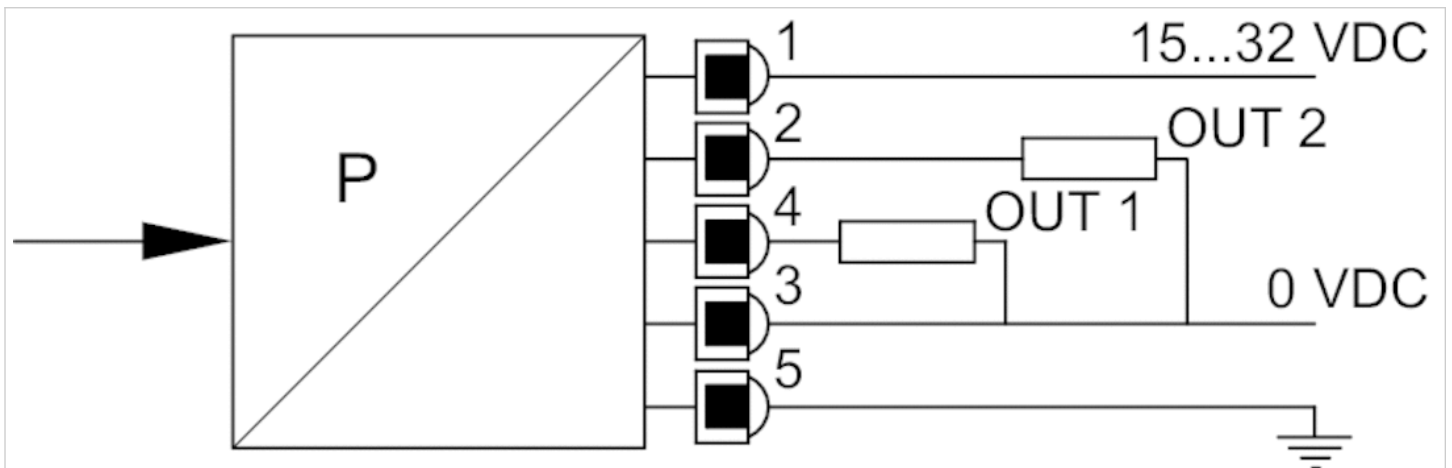

Block diagram, 1x PNP and 1x analog

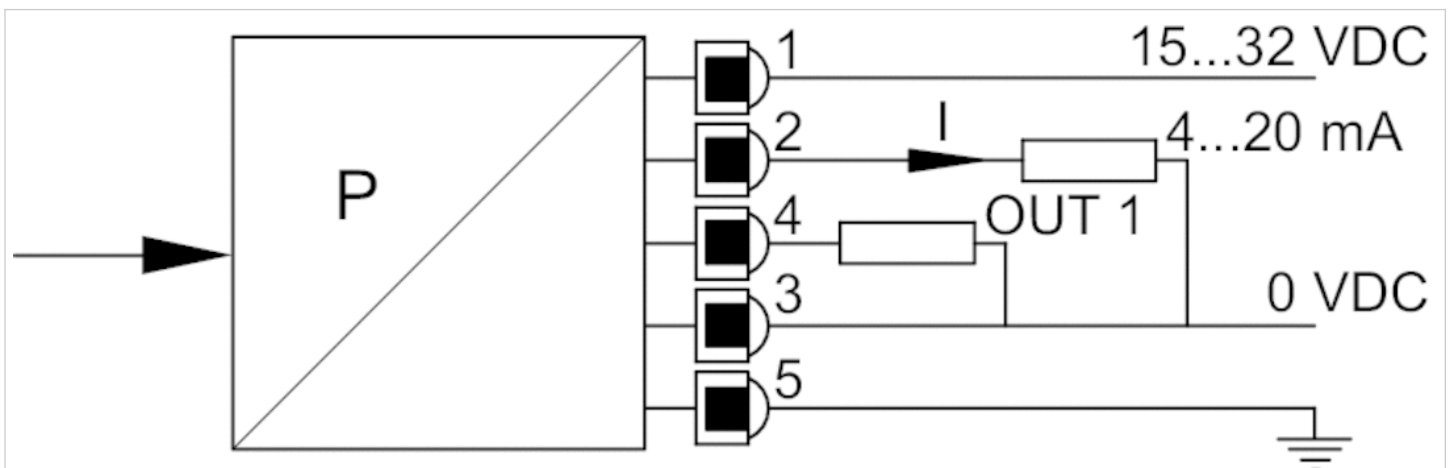

Pin assignments

Pin assignments

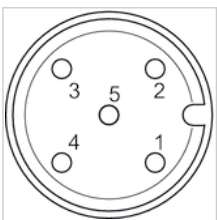

pin 1: signal + UB, color: brown pin 2: signal: out 2 (PNP)/analog 4 - 20 mA, color: white pin 3: signal: 0 volt, color: blue pin 4: signal: out 1 (PNP), color: black pin 5: signal: FE, color: gray







Pressure Switches, Series PM1

- Operating pressure -0.9 ... 0 -0.9 ... 3 0.2 ... 16 bar
- Mechanical
- Spring-loaded bellows, adjustable
- Electr. connection Plug EN 175301-803, form A
- Compressed air connection Internal thread G 1/4 Flange with O-ring Ø 5x1,5



Type	Mechanical
Function	change-over contact (mechanical)
Mounting orientation	Any
Working pressure min./max.	See table below
Ambient temperature min./max.	-20 ... 80 °C
Medium temperature min./max.	-10 ... 80 °C
Medium	Compressed air Hydraulic oil
Measurement	Relative pressure
Switching element	microswitch (input/output)
Protection against overpressure	80 bar
Max. switching frequency	1,5 Hz
Shock resistance max.	15 g
Vibration resistance	10 g (60 - 500 Hz)
Repeatability (% of full scale value)	± 1 %
Switching point	adjustable
Hysteresis	max. switching pressure difference
DC operating voltage min./max.	12 ... 30 V DC
Operational voltage AC min./max.	12 ... 250 V AC
Mounting types	via through holes
Protection class	IP65
Electr. connection	Plug EN 175301-803, form A
Weight	0.16 kg

Technical data

Part No.		Type	Operating pressure range	Compressed air connection
			min./max.	
R412010711		PM1-M3-G014	-0.9 ... 0 bar	Internal thread, G 1/4
R412022752		PM1-M3-G014	-0.9 ... 3 bar	Internal thread, G 1/4
R412010712		PM1-M3-G014	0.2 ... 16 bar	Internal thread, G 1/4
R412010713		PM1-M3-G014	0.2 ... 16 bar	Internal thread, G 1/4
R412010714		PM1-M3-F001	-0.9 ... 0 bar	Flange with O-ring, Ø 5x1,5
R412010715		PM1-M3-F001	0.2 ... 16 bar	Flange with O-ring, Ø 5x1,5
R412010718		PM1-M3-F001	0.2 ... 16 bar	Flange with O-ring, Ø 5x1,5

Part No.	Scope of delivery	Fig.	
R412010711	With valve plug connector	Fig. 1	-
R412022752	Without valve plug connector	Fig. 1	-
R412010712	Without valve plug connector	Fig. 1	1)
R412010713	With valve plug connector	Fig. 1	1)
R412010714	With valve plug connector	Fig. 2	-
R412010715	Without valve plug connector	Fig. 2	1)

Part No.	Scope of delivery	Fig.	
R412010718	With valve plug connector	Fig. 2	1)

1) Min. switching pressure range 0.2 bar falling/0.5 bar rising

Technical information

Switching function increasing pressure: contact switches from 1-2 to 1-3.

Switching function decreasing pressure: contact switches from 1-3 to 1-2.

Notice: Too-high currents can damage contacts. Inductive or capacitive loads must be equipped with appropriate spark-quenching!

The microswitch has silver-plated contacts.

Please observe the pin assignment when selecting plug connectors.

Technical information

Material	
Housing	Aluminum
Seals	Acrylonitrile butadiene rubber
Electr. connection	Brass, nickel-plated

Dimensions

Fig. 1

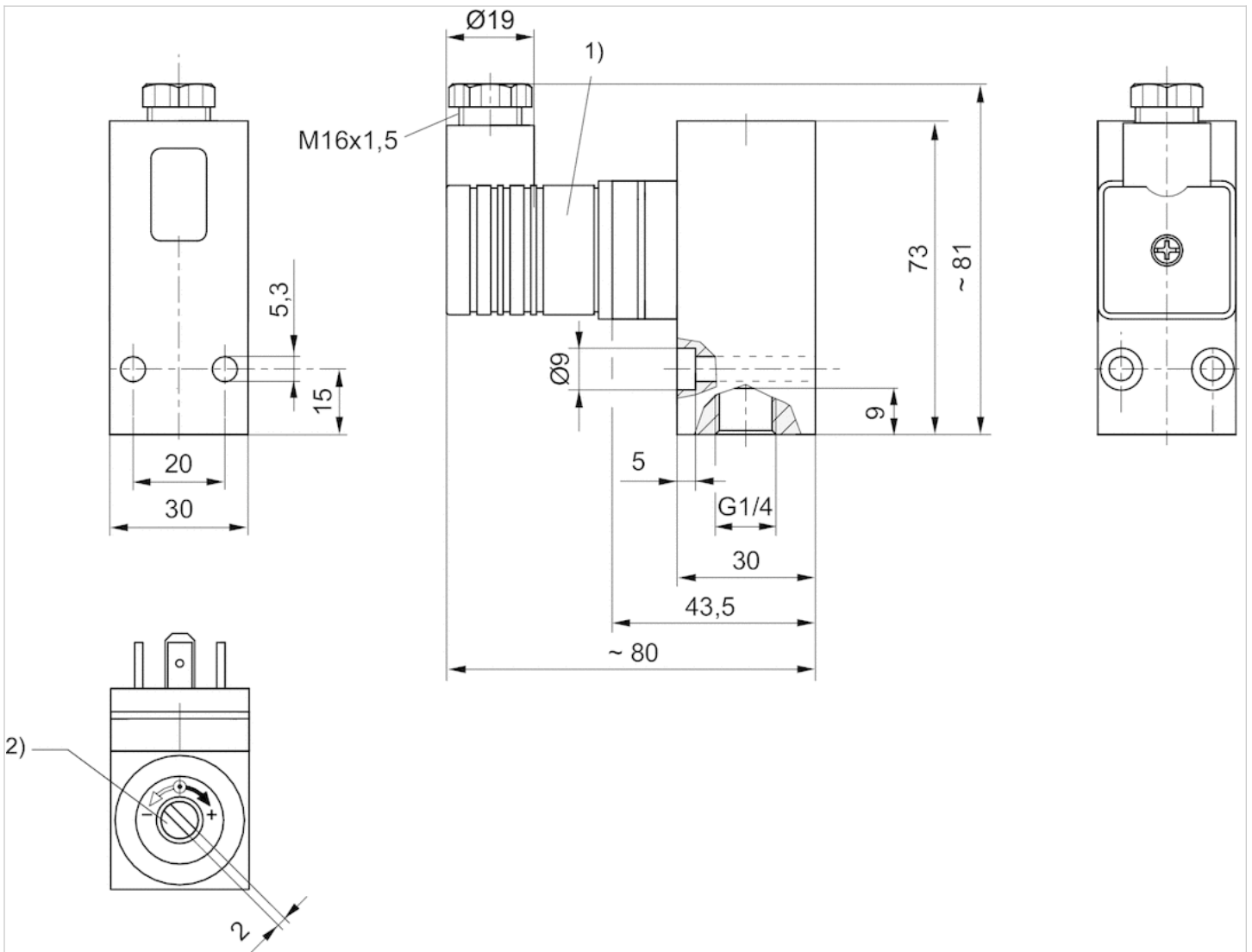

- 1) Valve plug connector
- 2) Adjustment screw, self-holding

Diagrams

differential switching pressure characteristic curve (-0,9 - 0 bar)

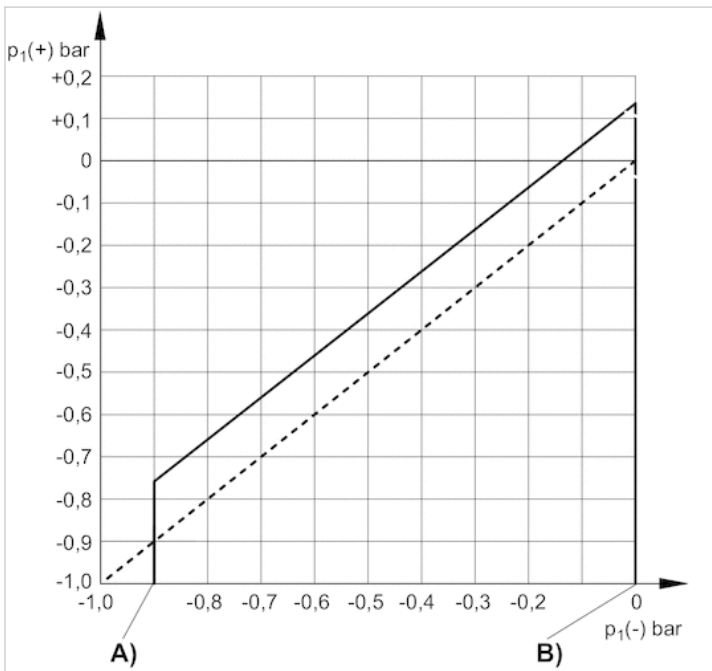

A) $p_1(-)$, min.

B) $p_1(-)$, max.

$p_1(+)$ = upper switching pressure with increasing pressure

$p_1(-)$ = lower switching pressure with decreasing pressure

differential switching pressure characteristic curve (0,2 - 16 bar)

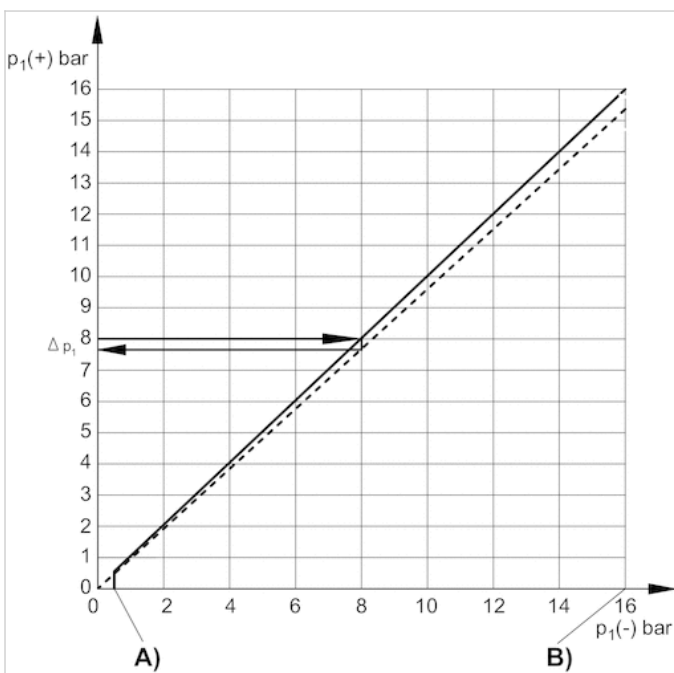

A) $p_1(-)$, min.

B) $p_1(-)$, max.

$p_1(+)$ = upper switching pressure with increasing pressure

$p_1(-)$ = lower switching pressure with decreasing pressure

Δp_1 = max. operating pressure difference or hysteresis

Example:

$p_1 (+) = 8 \text{ bar} > p_1 (-) = 7.6 \text{ bar}$
 $\Delta p_1 = 0.4 \text{ bar}$

max. permissible continuous current $I_{max.}$ [A] with ohmic load

U [V]	I [A] 1)	I [A] 2)
30	5	3
48	5	1,2
60	5	0,8
125	5	0,4
250	5	-

reference cycle: 30/min., reference temperature: + 30 °C

- 1) AC
- 2) DC

max. permissible continuous current $I_{max.}$ [A] with inductive load

U [V]	I [A] 1) 3)	I [A] 2) 4)
30	3	2
48	3	0.55
60	3	0.4
125	3	0.15
250	3	-

reference cycle: 30/min., reference temperature: + 30 °C

- 1) AC
- 2) DC
- 3) $\cos \approx 0,7^\circ$
- 4) L/R $\approx 10 \text{ ms}$

Pin assignments

PIN assignment for valve plug connectors

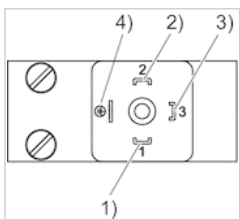

Pin	1	2	3	4
Allocation	+UB	break contact	NO (make contact)	GND





Pressure Switches, Series PM1

- Operating pressure -0.9 ... 0 0.2 ... 16 bar
- Mechanical
- Spring-loaded bellows, adjustable
- Electr. connection Plug M12x1
- Compressed air connection Internal thread G 1/4 Flange with O-ring Ø 5x1,5



Type	Mechanical
Function	change-over contact (mechanical)
Mounting orientation	Any
Working pressure min./max.	See table below
Ambient temperature min./max.	-20 ... 80 °C
Medium temperature min./max.	-10 ... 80 °C
Medium	Compressed air Hydraulic oil
Measurement	Relative pressure
Switching element	microswitch (input/output)
Protection against overpressure	80 bar
Max. switching frequency	1,5 Hz
Shock resistance max.	15 g
Vibration resistance	10 g (60 - 500 Hz)
Repeatability (% of full scale value)	± 1 %
Switching point	adjustable
Hysteresis	max. switching pressure difference
DC operating voltage min./max.	12 ... 30 V DC
Operational voltage AC min./max.	12 ... 30 V AC
Mounting types	via through holes
Protection class	IP67
Electr. connection	Plug M12x1
Weight	0.15 kg

Technical data

Part No.		Type	Operating pressure range	Compressed air connection
			min./max.	
R412010716		PM1-M3-G014	-0.9 ... 0 bar	Internal thread, G 1/4
R412010717		PM1-M3-G014	0.2 ... 16 bar	Internal thread, G 1/4
R412010719		PM1-M3-F001	-0.9 ... 0 bar	Flange with O-ring, Ø 5x1,5
R412010720		PM1-M3-F001	0.2 ... 16 bar	Flange with O-ring, Ø 5x1,5

Part No.	Fig.	
R412010716	Fig. 1	-
R412010717	Fig. 1	1)
R412010719	Fig. 2	-
R412010720	Fig. 2	1)

1) Min. switching pressure range 0.2 bar falling/0.5 bar rising

Technical information

Switching function increasing pressure: contact switches from 1-2 to 1-3.

Switching function decreasing pressure: contact switches from 1-3 to 1-2.

Notice: Too-high currents can damage contacts. Inductive or capacitive loads must be equipped with appropriate spark-quenching!

The microswitch has silver-plated contacts.

Technical information

Material	
Housing	Aluminum
Seals	Acrylonitrile butadiene rubber
Electr. connection	Brass, nickel-plated

Dimensions

Fig. 1

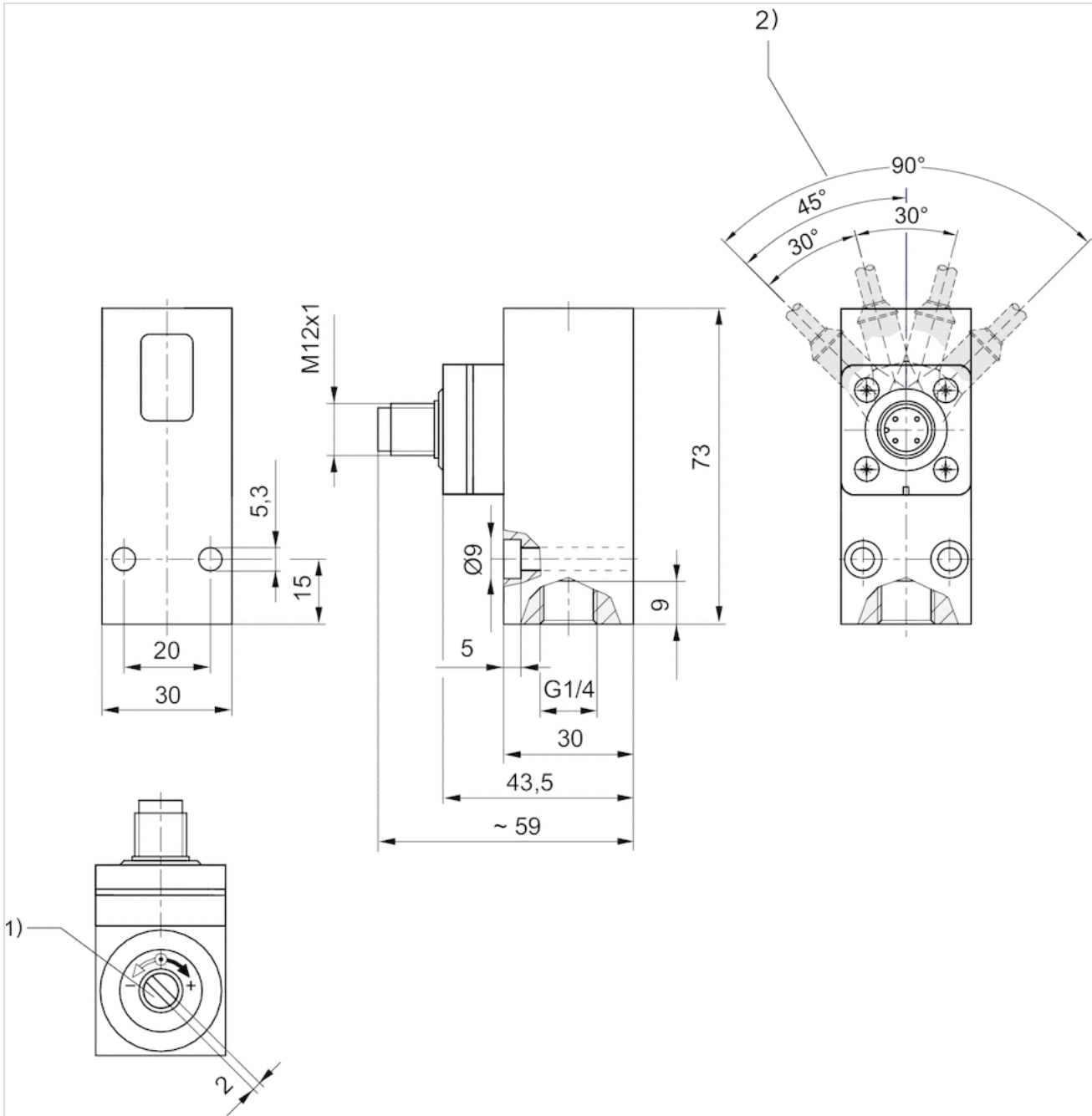

- 1) Adjustment screw, self-holding
- 2) Detent position

Fig. 2

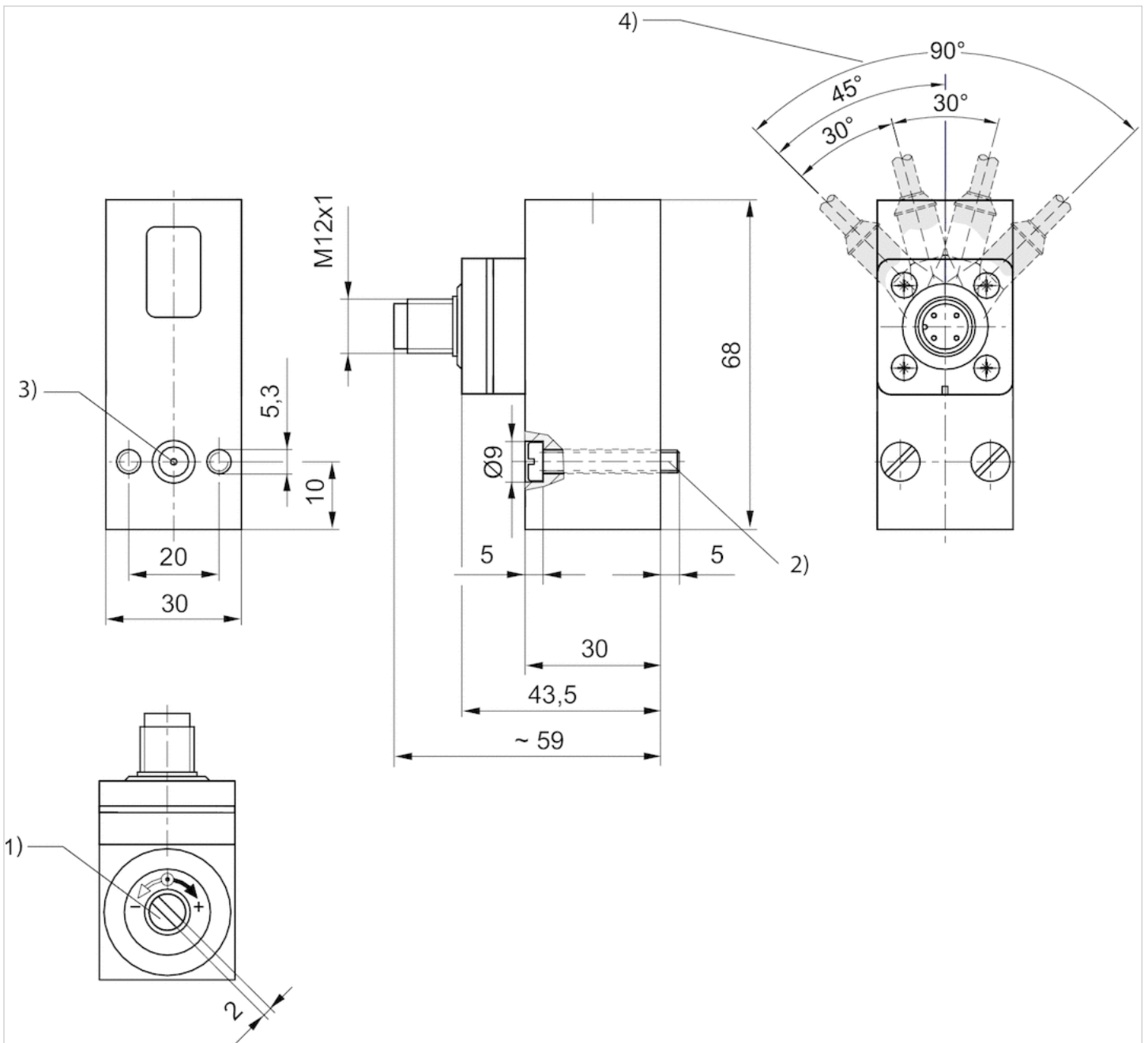

- 1) Adjustment screw, self-holding
- 2) cylinder screw M5x30 (included in scope of delivery)
- 3) O-ring Ø5x1,5 (included)
- 4) Detent position

Diagrams

differential switching pressure characteristic curve (-0,9 - 0 bar)

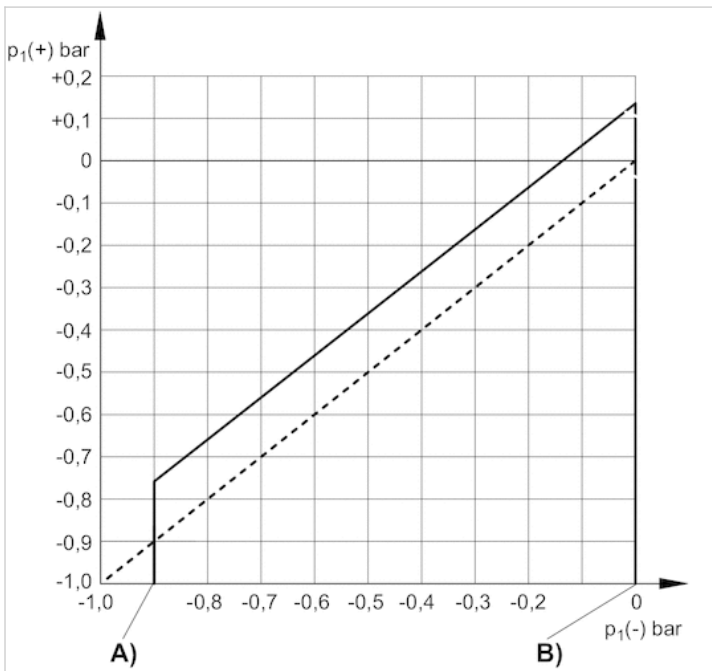

A) $p_1(-)$, min.

B) $p_1(-)$, max.

$p_1(+)$ = upper switching pressure with increasing pressure

$p_1(-)$ = lower switching pressure with decreasing pressure

differential switching pressure characteristic curve (0,2 - 16 bar)

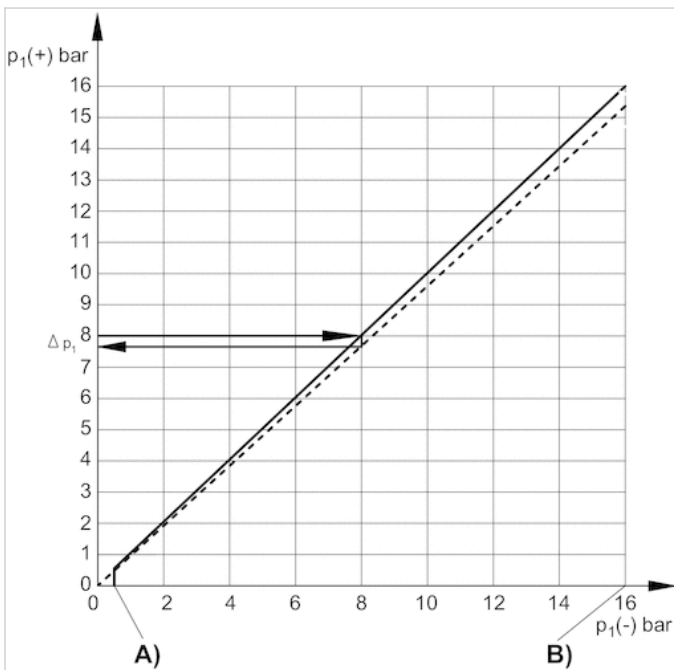

A) $p_1(-)$, min.

B) $p_1(-)$, max.

$p_1(+)$ = upper switching pressure with increasing pressure

$p_1(-)$ = lower switching pressure with decreasing pressure

Δp_1 = max. operating pressure difference or hysteresis

Example:

$p_1 (+) = 8 \text{ bar} > p_1 (-) = 7.6 \text{ bar}$
 $\Delta p_1 = 0.4 \text{ bar}$

max. permissible continuous current $I_{max.}$ [A] with ohmic load

U [V]	I [A] 1)	I [A] 2)
30-250	3A	
30 / 48 / 60 / 125		3 / 1,2 / 0,8 / 0,4

reference cycle: 30/min., reference temperature: + 30 °C

- 1) AC
- 2) DC

max. permissible continuous current $I_{max.}$ [A] with inductive load

U [V]	I [A] 1) 3)	I [A] 2) 4)
30-250	3A	
30 / 48 / 60 / 125		2 / 0,55 / 0,4 / 0,2

reference cycle: 30/min., reference temperature: + 30 °C

- 1) AC
- 2) DC
- 3) $\cos \approx 0,7^\circ$
- 4) $L/R \approx 10 \text{ ms}$

Pin assignments

Pin assignments

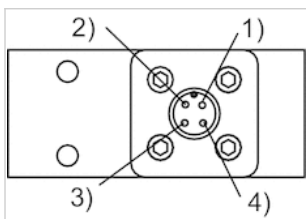

Pin	1	2	3	4
Allocation	+UB	break contact	No function	NO (make contact)

Sensor, Series ST6

- 6 mm T-slot
- with cable
- Plug, M12, 4-pin, with knurled screw
- UL certification
- Reed
- Direct mounting for series PRA PRE CCI KPZ SSI GPC CVI
- Indirect mounting for series TRB, ITS, CCL-IS, MNI, CSL-RD, RPC, ICS-D2, ICM, KHZ, TRR



Certificates	CE declaration of conformity cULus RoHS
Ambient temperature min./max.	-30 ... 80 °C
Protection class	IP65, IP67
Switching point precision	±0,1 mT
Min./max. DC operating voltage	10 ... 30 V DC
Min./max. AC operating voltage	10 ... 30 V AC
Hysteresis	≥ 0,2 mT
Switching logic	NO (make contact)
Switching capacity	Reed, 3-pin: max. 6 W
LED status display	Yellow
Vibration resistance	10 - 55 Hz, 1 mm
Shock resistance	30 g / 11 ms
Cable length L	0.3 m

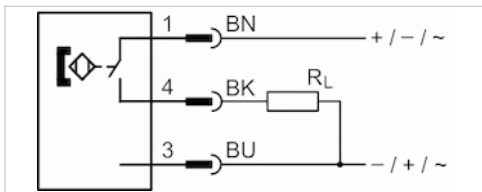

Technical data

Part No.	for	Type of contact	Cable length L
R412022876	PRA PRE CCI KPZ SSI GPC CVI	Reed	0.3 m

Part No.	Voltage drop U at I _{max}	DC switching current, max.
R412022876	≤ 0,1 V	0.3 A

Part No.	AC switching current, max.	Max. switching frequency
R412022876	0.5 A	400 Hz

Part No.	Version
R412022876	Protected against polarity reversal

The product of operating voltage and continuous current must not exceed the maximum switching capacity.

Technical information

Material

Housing	Polyamide
Cable sheath	Polyurethane
Locking screw	Stainless steel

Dimensions

Dimensions

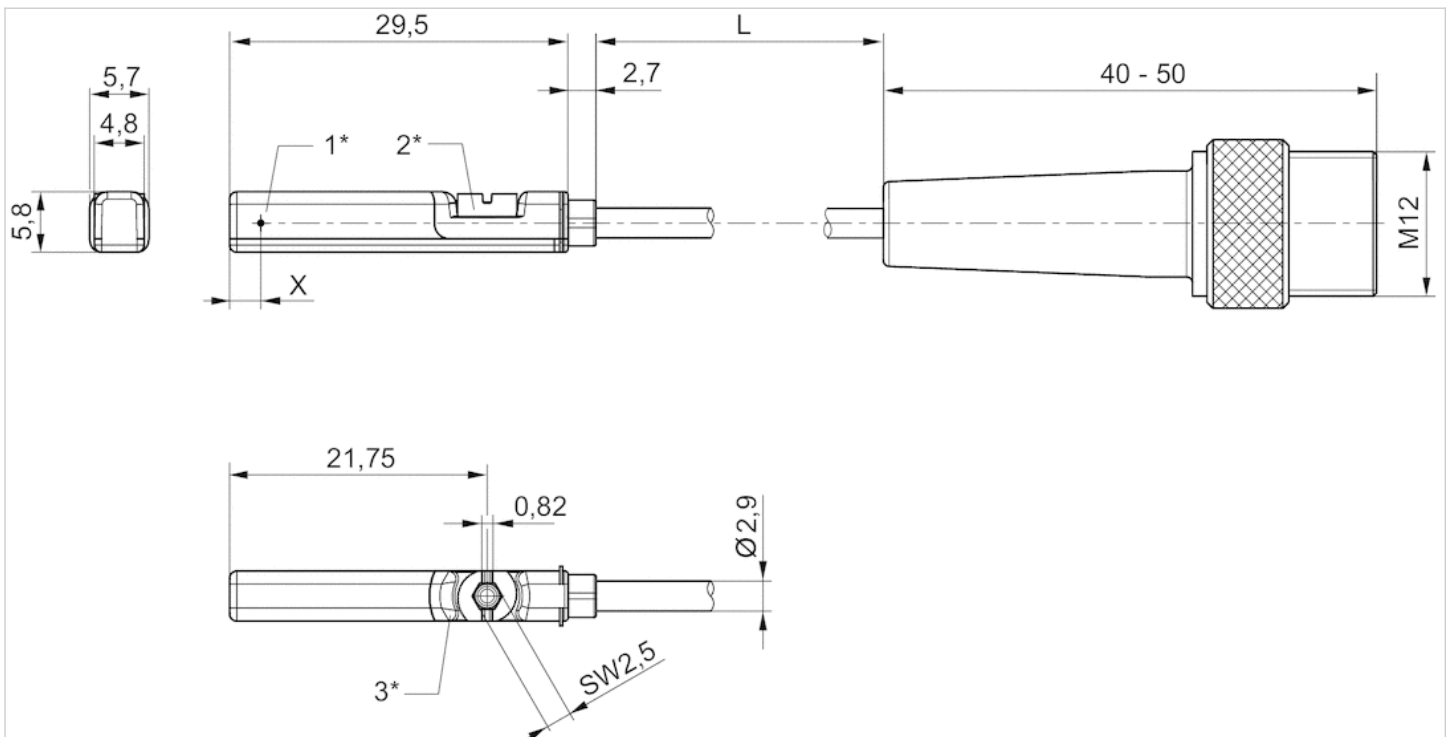

1* = switching point 2* = locking screw 3* = LED window, transparent

L = cable length

X = PNP: 11,6 mm, reed: 8,3 mm

Sensor, Series ST6

- 6 mm T-slot
- with cable
- Plug, M8, 3-pin, with knurled screw
- UL certification
- Reed
- Direct mounting for series PRA PRE CCI KPZ SSI GPC CVI
- Indirect mounting for series TRB, ITS, CCL-IS, MNI, CSL-RD, RPC, ICS-D2, ICM, KHZ, TRR

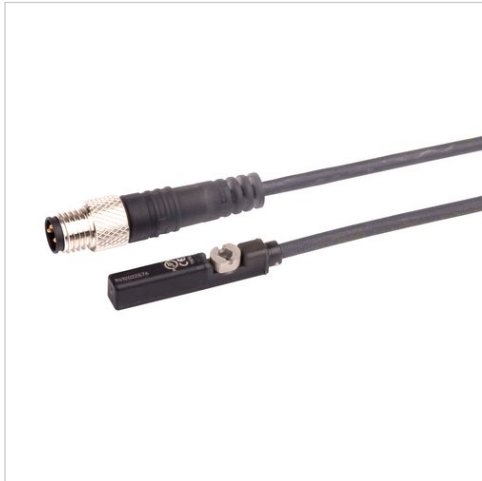

Certificates	CE declaration of conformity cULus RoHS
Ambient temperature min./max.	-30 ... 80 °C
Protection class	IP65, IP67
Switching point precision	±0,1 mT
Min./max. DC operating voltage	10 ... 30 V DC
Min./max. AC operating voltage	10 ... 30 V AC
Hysteresis	≥ 0,2 mT
Switching logic	NO (make contact)
Switching capacity	Reed, 3-pin: max. 6 W
LED status display	Yellow
Vibration resistance	10 - 55 Hz, 1 mm
Shock resistance	30 g / 11 ms
Cable length L	0.3 0.5 m

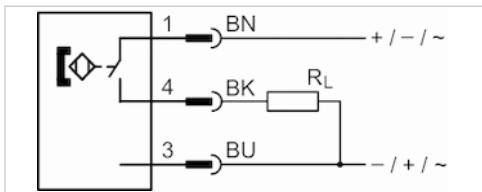

Technical data

Part No.	for	Type of contact	Cable sheath
R412022873	PRA PRE CCI KPZ SSI GPC CVI	Reed	Polyurethane
R412022875	PRA PRE CCI KPZ SSI GPC CVI	Reed	Polyvinyl chloride
R412022874	PRA PRE CCI KPZ SSI GPC CVI	Reed	Polyurethane

Part No.	Cable length L	Voltage drop U at I _{max}	DC switching current, max.
R412022873	0.3 m	I*Rs	0.3 A
R412022875	0.3 m	I*Rs	0.3 A
R412022874	0.5 m	I*Rs	0.3 A

Part No.	AC switching current, max.	Max. switching frequency
R412022873	0.5 A	400 Hz
R412022875	0.5 A	400 Hz
R412022874	0.5 A	400 Hz

Part No.	Version
R412022873	Protected against polarity reversal
R412022875	Protected against polarity reversal
R412022874	Protected against polarity reversal

Technical information

Material	
Housing	Polyamide
Cable sheath	Polyurethane Polyvinyl chloride
Locking screw	Stainless steel

Dimensions

Dimensions

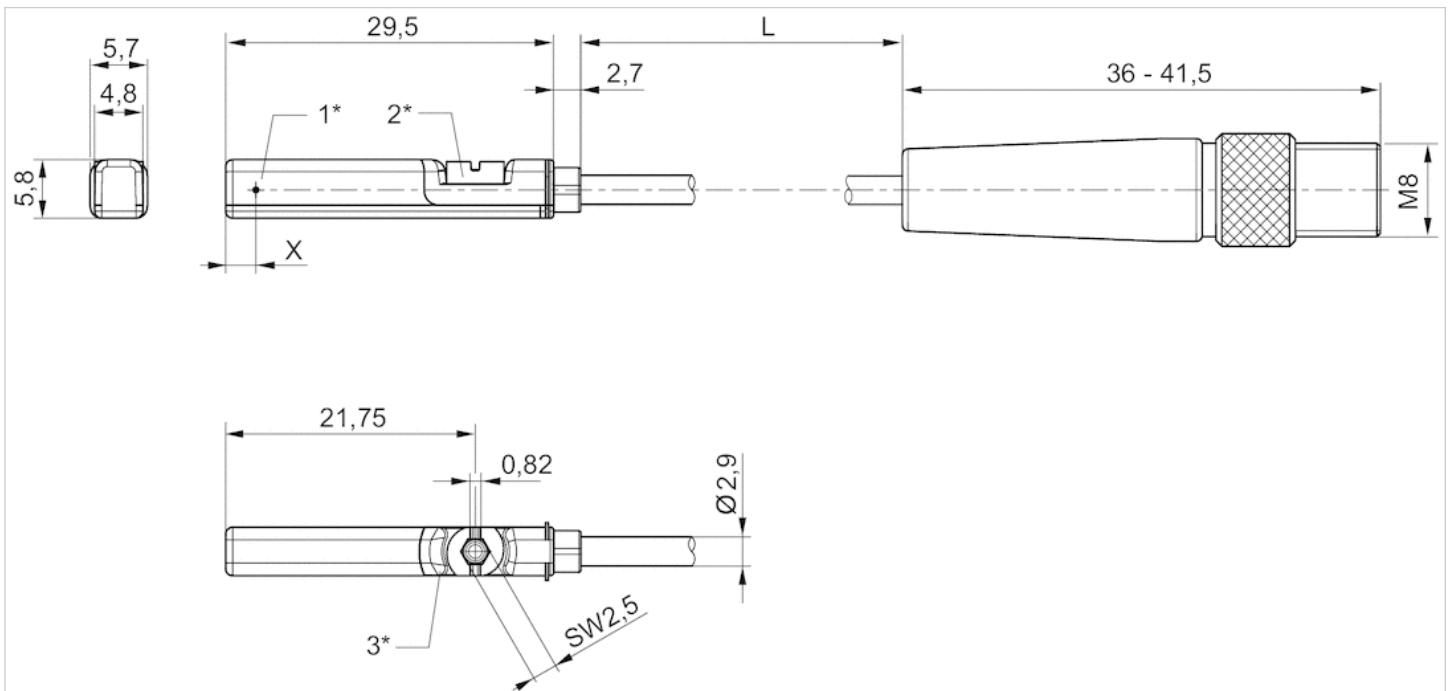

1* = switching point 2* = locking screw 3* = LED window, transparent
 L = cable length
 X = electronic: 11,6 mm, Reed: 8,3 mm

Pin assignments

Pin assignments

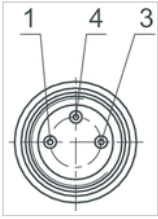

Pin	1	3	4
Allocation	(+)	(-)	(OUT)

Sensor, Series ST6

- 6 mm T-slot
- with cable
- open cable ends, 3-pin
- UL certification
- Reed
- Direct mounting for series PRA PRE CCI KPZ SSI GPC CVI
- Indirect mounting for series TRB, ITS, CCL-IS, MNI, CSL-RD, RPC, ICS-D2, ICM, KHZ, TRR



Certificates	CE declaration of conformity cULus RoHS
Ambient temperature min./max.	-30 ... 80 °C
Protection class	IP65, IP67, IP69K
Switching point precision	±0,1 mT
Min./max. DC operating voltage	10 ... 30 V DC
Min./max. AC operating voltage	10 ... 30 V AC
Hysteresis	≥ 0,2 mT
Switching logic	NO (make contact)
Switching capacity	Reed, 3-pin: max. 6 W
LED status display	Yellow
Vibration resistance	10 - 55 Hz, 1 mm
Shock resistance	30 g / 11 ms
Cable length L	3 5 10 m

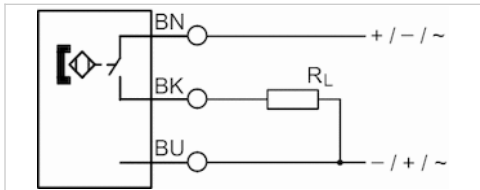

Technical data

Part No.	for	Type of contact	Cable length L
R412022869	PRA PRE CCI KPZ SSI GPC CVI	Reed	3 m
R412022870	PRA PRE CCI KPZ SSI GPC CVI	Reed	5 m
R412022871	PRA PRE CCI KPZ SSI GPC CVI	Reed	10 m

Part No.	Voltage drop U at I _{max}	DC switching current, max.
R412022869	I*Rs	0.3 A
R412022870	≤ 0,1 V	0.3 A
R412022871	I*Rs	0.3 A

Part No.	AC switching current, max.	Max. switching frequency
R412022869	0.5 A	400 Hz
R412022870	0.5 A	400 Hz
R412022871	0.5 A	400 Hz

Part No.	Version	Fig.
R412022869	Protected against polarity reversal	Fig. 2
R412022870	Protected against polarity reversal	Fig. 2
R412022871	Protected against polarity reversal	Fig. 2

open cable ends, 3-pin, The product of operating voltage and continuous current must not exceed the maximum switching capacity.

Technical information

No cULus certification for 230 V variant.

Technical information

Material

Housing	Polyamide
Cable sheath	Polyurethane
Locking screw	Stainless steel

Dimensions

Fig. 1

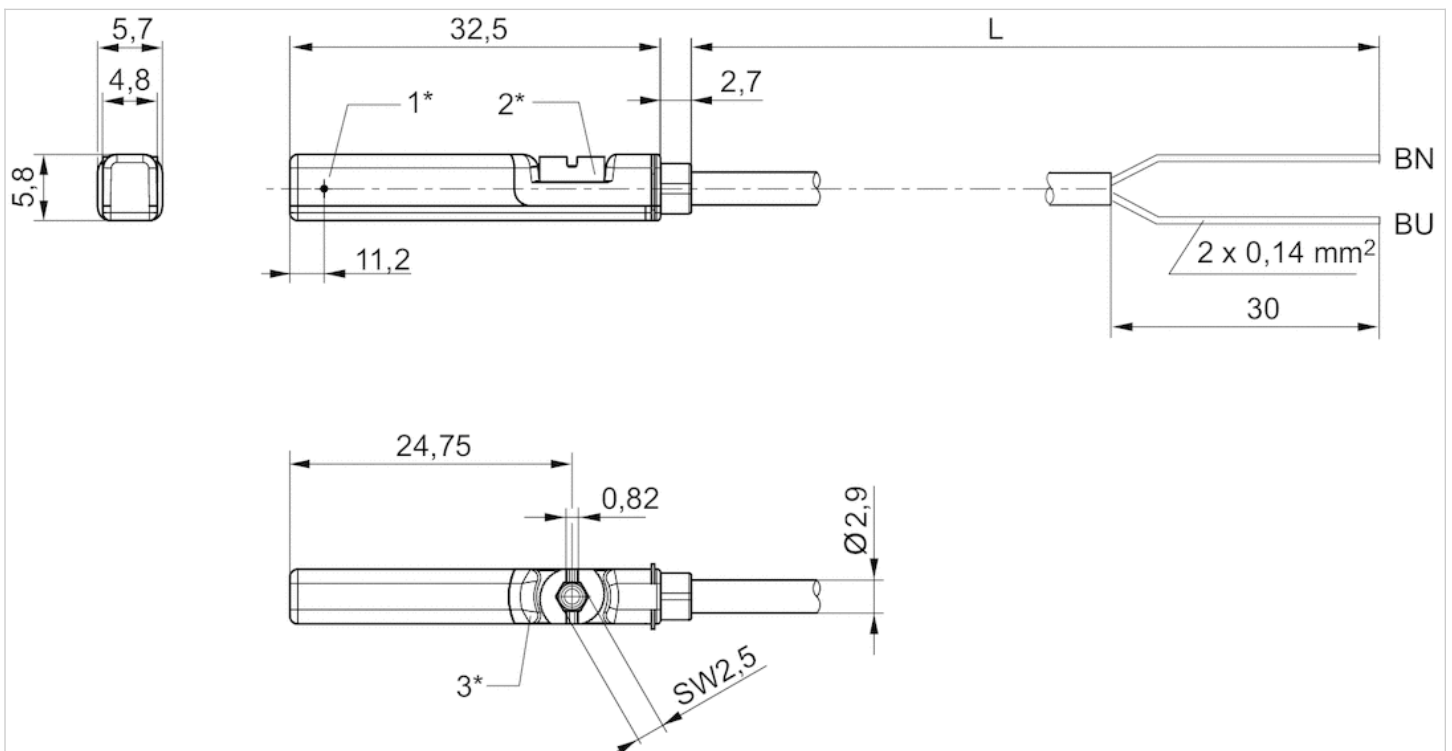

1* = switching point 2* = locking screw 3* = LED window, transparent
 L = cable length
 BN=brown, BU=blue

Fig. 2

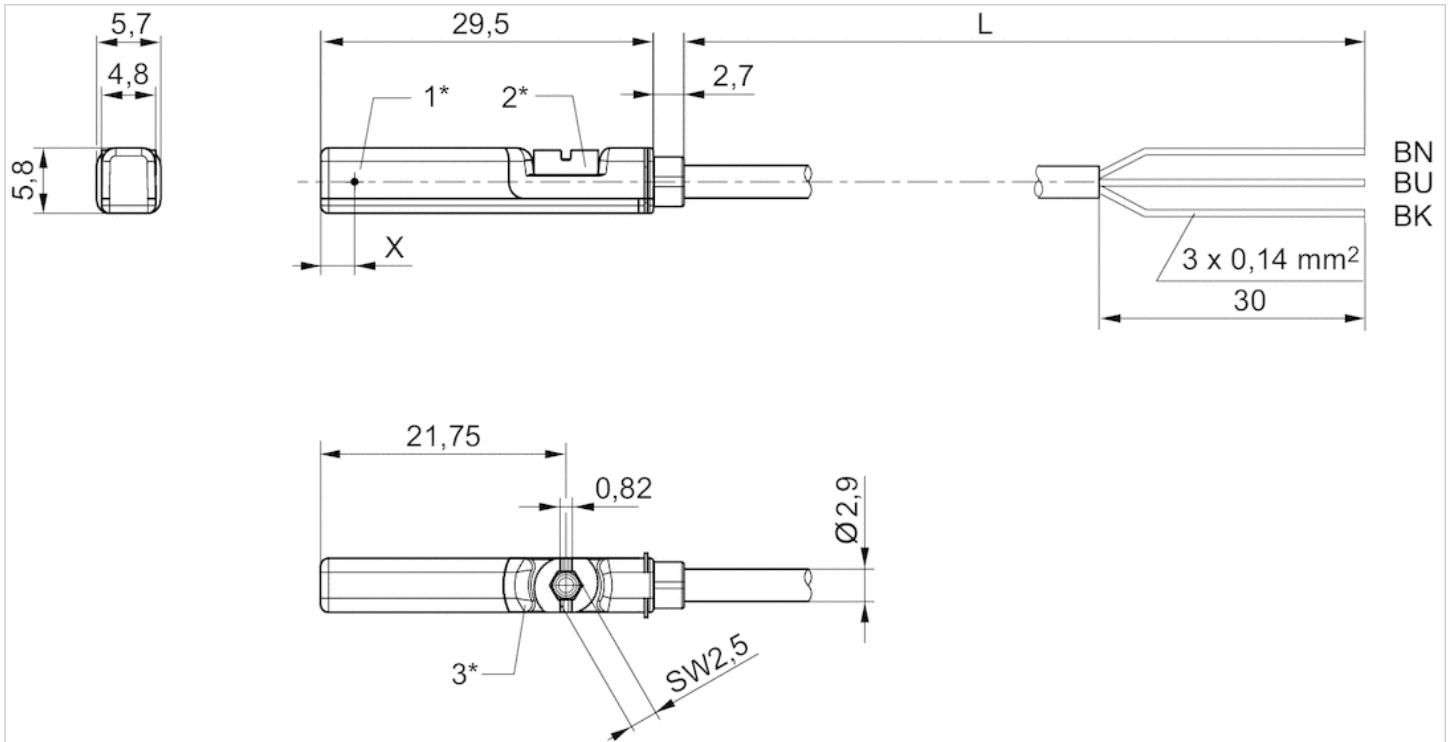

1* = switching point 2* = locking screw 3* = LED window, transparent
 L = cable length
 BN = brown, BK = black, BU = blue
 X = electronic: 11.6 mm

QR1-S-RPN standard series

- Straight fitting
- External thread
- G 1/4 G 3/8
- push-in fitting
- Ø 4 Ø 6 Ø 8 Ø 10 Ø 12 Ø 14 Ø 16
- QR1-S-RPN



Working pressure min./max.	-0.95 ... 10 bar
Ambient temperature min./max.	0 ... 60 °C
Weight per piece	See table below

Technical data

Part No.	Port G	Port D	Delivery unit	Weight per piece
2121004140	G 1/4	Ø 4	10 piece	0.02 kg
2121006140	G 1/4	Ø 6	10 piece	0.021 kg
2121008140	G 1/4	Ø 8	10 piece	0.024 kg
2121010140	G 1/4	Ø 10	10 piece	0.026 kg
2121012140	G 1/4	Ø 12	10 piece	0.039 kg
R412005000	G 3/8	Ø 6	10 piece	0.032 kg
2121008380	G 3/8	Ø 8	10 piece	0.035 kg
2121010380	G 3/8	Ø 10	10 piece	0.042 kg
2121012380	G 3/8	Ø 12	10 piece	0.045 kg
2121014380	G 3/8	Ø 14	10 piece	0.046 kg
R412005005	G 3/8	Ø 16	10 piece	0.058 kg

Technical information

The series QR1 (plastic) and QR2 (metal) can not be combined
Thread seal with captive O-ring

For further information about assembling and tolerances of adaptable tubing can be found in the "Technical information" document (available in the MediaCentre).

Technical information

Material	
Material	nickel-plated
Housing	Brass, nickel-plated
Seal	Acrylonitrile butadiene rubber
Tooth lock washer	Stainless steel
Release ring	Polyoxymethylene
Release ring holder	Die cast zinc Brass, nickel-plated
Thread	Brass, nickel-plated

Dimensions

Dimensions

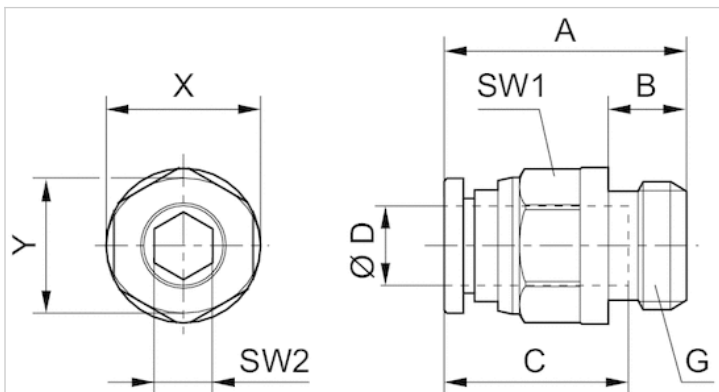

Dimensions

Part No.	Port D	Port G	A	B	C	SW1	SW2	X	Y
2121004140	Ø 4	G 1/4	19.1	6	16	10	3	12	10
2121006140	Ø 6	G 1/4	21.6	6	17	12	4	14	12
2121008140	Ø 8	G 1/4	22.4	6	18.5	14	6	16	14
2121010140	Ø 10	G 1/4	29.9	6	21	17	7	19	17
2121012140	Ø 12	G 1/4	33.4	6	22.5	21	7	23	21
R412005000	Ø 6	G 3/8	21.6	7	17	12	4	14	12
2121008380	Ø 8	G 3/8	23.2	7	18.5	14	6	16	14
2121010380	Ø 10	G 3/8	25.9	7	21	17	8	19	17
2121012380	Ø 12	G 3/8	33.5	7	23	21	9	23	21
2121014380	Ø 14	G 3/8	30.1	7	24.6	22	9	25	23
R412005005	Ø16	G 3/8	35.3	7	25.5	24	8	27	24

QR1-S-RVT standard series

- Elbow fitting
- External thread
- G 1/4 G 3/8
- push-in fitting
- Ø 4 Ø 6 Ø 8 Ø 10 Ø 12 Ø 14 Ø 16
- QR1-S-RVT



Working pressure min./max.	-0.95 ... 10 bar
Ambient temperature min./max.	0 ... 60 °C
Weight per piece	See table below

Technical data

Part No.	Port G	Port D	Delivery unit	Weight per piece
2122004140	G 1/4	Ø 4	10 piece	0.017 kg
2122006140	G 1/4	Ø 6	10 piece	0.019 kg
2122008140	G 1/4	Ø 8	10 piece	0.023 kg
2122010140	G 1/4	Ø 10	10 piece	0.029 kg
2122012140	G 1/4	Ø 12	10 piece	0.042 kg
R412005092	G 3/8	Ø 6	10 piece	0.031 kg
2122008380	G 3/8	Ø 8	10 piece	0.033 kg
2122010380	G 3/8	Ø 10	10 piece	0.04 kg
2122012380	G 3/8	Ø 12	10 piece	0.044 kg
2122014380	G 3/8	Ø 14	5 piece	0.048 kg
R412005097	G 3/8	Ø 16	5 piece	0.061 kg

Technical information

The series QR1 (plastic) and QR2 (metal) can not be combined
Thread seal with captive O-ring

For further information about assembling and tolerances of adaptable tubing can be found in the "Technical information" document (available in the MediaCentre).

Technical information

Material	
Material	nickel-plated
Housing	Polybutyleneterephthalate
Seal	Acrylonitrile butadiene rubber
Tooth lock washer	Stainless steel
Release ring	Polyoxymethylene
Release ring holder	Die cast zinc Brass, nickel-plated
Thread	Brass, nickel-plated

Dimensions

Dimensions

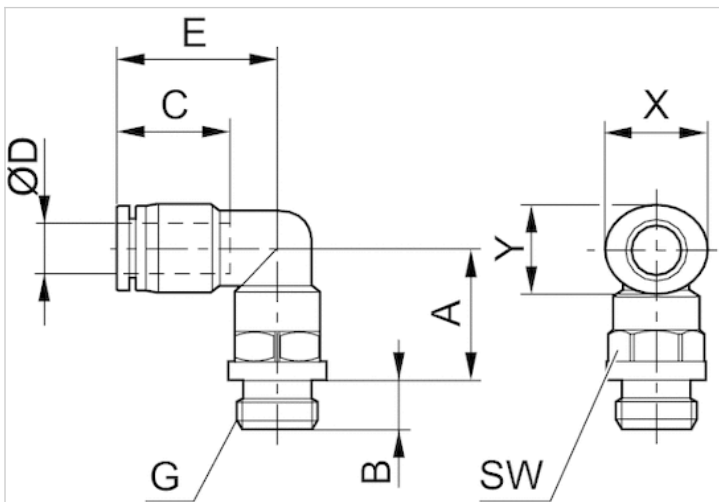

Dimensions

Part No.	Port D	Port G	A	B	C	E	SW	X	Y
2122004140	Ø 4	G 1/4	9.5	6	16	18.5	16	12	10
2122006140	Ø 6	G 1/4	10.7	6	17	20.3	16	14	12
2122008140	Ø 8	G 1/4	11.5	6	18.5	22.6	16	16	14
2122010140	Ø 10	G 1/4	16.5	6	21	27	16	19	17
2122012140	Ø 12	G 1/4	18.3	6	22.5	29.2	16	23	21
R412005092	Ø 6	G 3/8	11.2	7	17	20.3	20	14	12
2122008380	Ø 8	G 3/8	11.5	7	18.5	22.6	20	16	14
2122010380	Ø 10	G 3/8	13.6	7	21	27	20	19	16
2122012380	Ø 12	G 3/8	15.3	7	22.5	29.2	20	23	21
2122014380	Ø 14	G 3/8	23.1	7	24.6	32.1	20	25	23
R412005097	Ø16	G 3/8	24.2	7	24.8	33.3	20	27	24

Series QR2-S-RPN standard

- Straight fitting
- External thread
- G 1/4 G 3/8
- push-in fitting
- Ø 4 Ø 5 Ø 6 Ø 8 Ø 10 Ø 12 Ø 14
- QR2-S-RPN



Working pressure min./max.

-0.95 ... 16 bar

Ambient temperature min./max.

-20 ... 80 °C

Weight per piece

See table below

Technical data

Part No.	Port G	Port D	Delivery unit	Weight per piece	Fig.
1823373045	G 1/4	Ø 4	25 piece	0.012 kg	Fig. 1
1823373046	G 1/4	Ø 5	10 piece	0.013 kg	Fig. 1
1823373047	G 1/4	Ø 6	25 piece	0.015 kg	Fig. 1
1823373048	G 1/4	Ø 8	10 piece	0.016 kg	Fig. 1
1823373049	G 1/4	Ø 10	10 piece	0.026 kg	Fig. 1
1823391809	G 1/4	Ø 12	10 piece	0.031 kg	Fig. 1
R412004708	G 1/4	Ø 12	10 piece	0.022 kg	Fig. 2
1823373050	G 3/8	Ø 8	10 piece	0.021 kg	Fig. 1
1823373051	G 3/8	Ø 10	10 piece	0.028 kg	Fig. 1
1823373052	G 3/8	Ø 12	5 piece	0.038 kg	Fig. 1
1823373053	G 3/8	Ø 14	5 piece	0.059 kg	Fig. 1

Technical information

The series QR1 (plastic) and QR2 (metal) can not be combined
Thread seal with captive O-ring

For further information about assembling and tolerances of adaptable tubing can be found in the "Technical information" document (available in the MediaCentre).

Technical information

Material	
Housing	Brass, nickel-plated
Seal	Acrylonitrile butadiene rubber
Tooth lock washer	Stainless steel
Release ring	Brass, nickel-plated
Thread	Brass, nickel-plated

Dimensions

Fig. 1

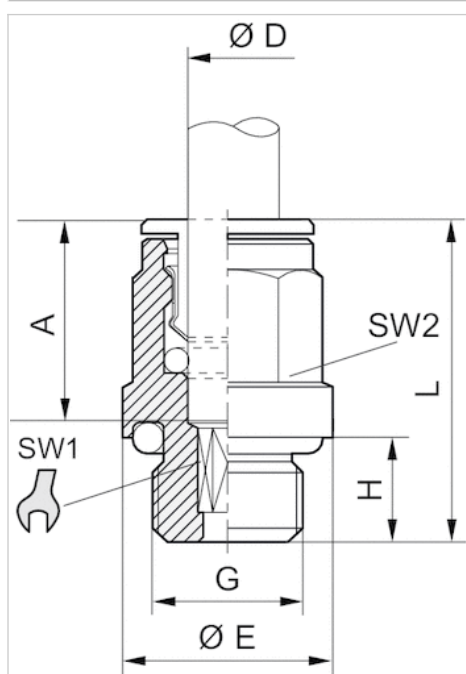
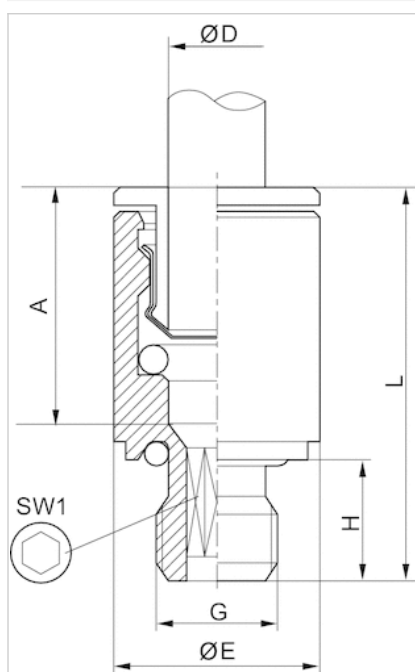

Fig. 2



Dimensions

Part No.	Port D	Port G	Ø E	H	L	A Insertion depth	SW 1	SW 2	Fig.
1823373045	Ø 4	G 1/4	17	8	21	15	2.5	9	Fig. 1
1823373046	Ø 5	G 1/4	17	8	22	16	4	10	Fig. 1
1823373047	Ø 6	G 1/4	17	6.5	22.5	16	4	11	Fig. 1
1823373048	Ø 8	G 1/4	17	8	25	18	6	13	Fig. 1
1823373049	Ø 10	G 1/4	16	8	29.5	19	7	16	Fig. 1
1823391809	Ø 12	G 1/4	16	6.5	30	20	7	18	Fig. 1
R412004708	Ø 12	G 1/4	17	8.3	31	7	-	-	Fig. 2
1823373050	Ø 8	G 3/8	20	9	25	18	6	13	Fig. 1
1823373051	Ø 10	G 3/8	21	9	29.5	19	8	16	Fig. 1
1823373052	Ø 12	G 3/8	21	9	31	20	10	18	Fig. 1
1823373053	Ø 14	G 3/8	21	9	34	22	10	21	Fig. 1

Series QR2-S-RVT standard

- Elbow fitting, rotatable
- External thread
- G 1/4 G 3/8
- push-in fitting
- Ø 4 Ø 6 Ø 8 Ø 10 Ø 12 Ø 14 Ø 16
- QR2-S-RVT



Working pressure min./max.	-0.95 ... 16 bar
Ambient temperature min./max.	-20 ... 80 °C
Weight per piece	See table below

Technical data

Part No.	Port G	Port D	Delivery unit	Weight per piece
1823391713	G 1/4	Ø 4	10 piece	0.024 kg
1823391714	G 1/4	Ø 6	10 piece	0.025 kg
1823391715	G 1/4	Ø 8	10 piece	0.027 kg
1823391718	G 1/4	Ø 10	5 piece	0.031 kg
1823391843	G 1/4	Ø 12	5 piece	0.042 kg
1823391716	G 3/8	Ø 8	5 piece	0.042 kg
1823391717	G 3/8	Ø 10	5 piece	0.042 kg
1823391838	G 3/8	Ø 12	5 piece	0.045 kg
1823391839	G 3/8	Ø 14	5 piece	0.062 kg
R412010182	G 3/8	Ø 16	1 piece	0.072 kg

Technical information

The series QR1 (plastic) and QR2 (metal) can not be combined
Thread seal with captive O-ring

For further information about assembling and tolerances of adaptable tubing can be found in the "Technical information" document (available in the MediaCentre).

Technical information

Material	
Housing	Brass, nickel-plated
Seal	Acrylonitrile butadiene rubber

Material	
Tooth lock washer	Stainless steel
Release ring	Brass, nickel-plated
Thread	Brass, nickel-plated

Dimensions

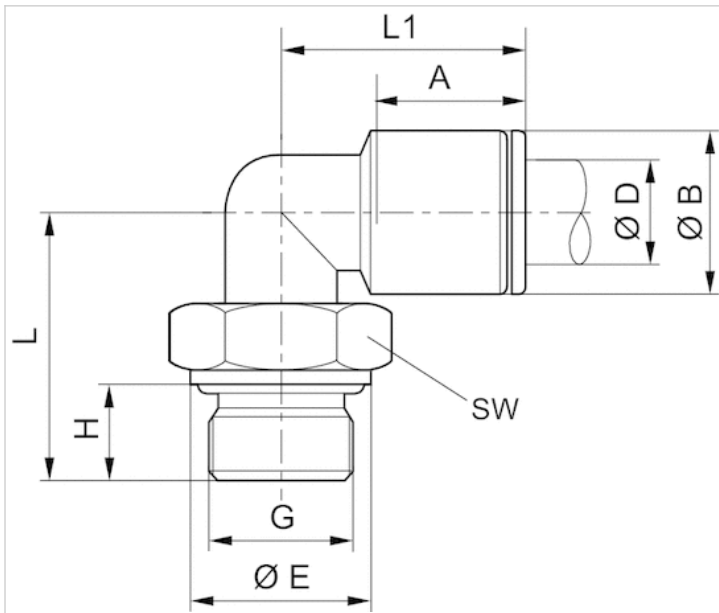

Dimensions

Part No.	Port D	Port G	ØB	ØE	H	L	L1	A Insertion depth	SW
1823391713	Ø 4	G 1/4	9	16	8	24	19	15	13
1823391714	Ø 6	G 1/4	11	16	8	24	21	16	13
1823391715	Ø 8	G 1/4	13	16	8	24	24	18	13
1823391718	Ø 10	G 1/4	15	16	8	24	27	19	16
1823391843	Ø 12	G 1/4	17	16	8	30.5	29	20	16
1823391716	Ø 8	G 3/8	13	20	9	25.5	24	18	13
1823391717	Ø 10	G 3/8	15	20	9	28	27	19	16
1823391838	Ø 12	G 3/8	17	20	9	28.5	28	20	20
1823391839	Ø 14	G 3/8	20	20	9	28.5	31	22	20
R412010182	Ø16	G 3/8	23	20	9	33.5	33	23.5	20

Series NU2

- Swivel banjo connection 1-fold
- External thread
- G 1/4 G 3/8
- plug-in with tube nut
- Ø 6 Ø 8 Ø 9 Ø 13
- NU2-S-RW1



Working pressure min./max.	-0.95 ... 10 bar
Ambient temperature min./max.	-10 ... 60 °C
Weight per piece	See table below

Technical data

Part No.	Port G	Port D	Delivery unit	Weight per piece
1823391294	G 1/4	Ø 6	2 piece	0.034 kg
1823391295	G 1/4	Ø 8	2 piece	0.044 kg
R412010658	G 1/4	Ø 9	2 piece	0.276 kg
1823391296	G 3/8	Ø 8	2 piece	0.056 kg
R412007839	G 3/8	Ø 13	2 piece	0.079 kg

Technical information

For further information about assembling and tolerances of adaptable tubing can be found in the "Technical information" document (available in the MediaCentre).

Technical information

Material	
Housing	Aluminum, anodized
Seal	Polyvinyl chloride

Dimensions

Dimensions

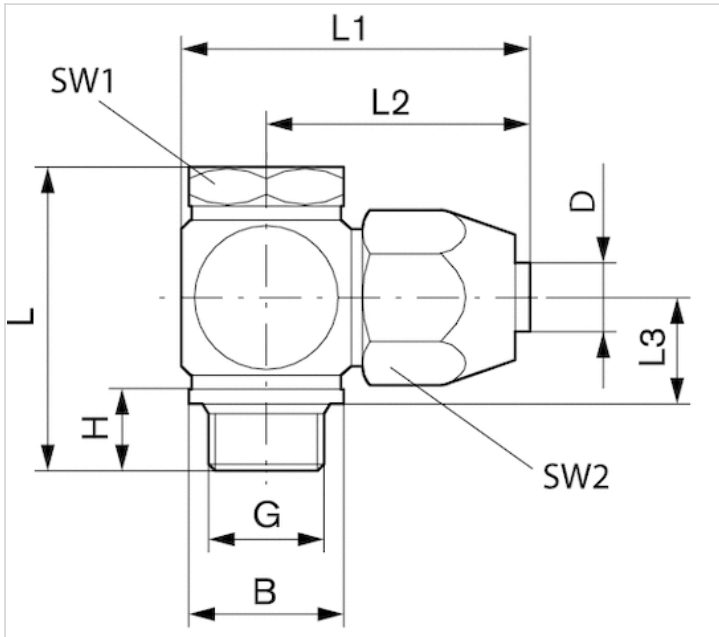

for fabric-reinforced plastic tubing

Dimensions

Part No.	Port D	Port G	B	H	L	L1	L2	L3	SW1	SW2
1823391294	Ø 6	G 1/4	18	12.5	39	39.5	30	14.5	17	19
1823391295	Ø 8	G 1/4	18	12.5	42	42	32.5	16	17	22
R412010658	Ø 9	G 1/4	18.9	7.9	40	42	32.5	15.6	17	24
1823391296	Ø 8	G 3/8	21	12.5	43	47	35	15.5	22	22
R412007839	Ø 13	G 3/8	22.9	12.5	47	49	37	18.5	22	30

Connection D = inside diameter of the tubing to be used

Double nipple, Series PE5

- External thread



Weight per piece

0.04 kg

Technical data

Part No.	Port G	Port D	Delivery unit
R412010015	G 1/4	G 1/8	2 piece
R412010016	G 1/4	G 1/4	2 piece

Dimensions

Dimensions

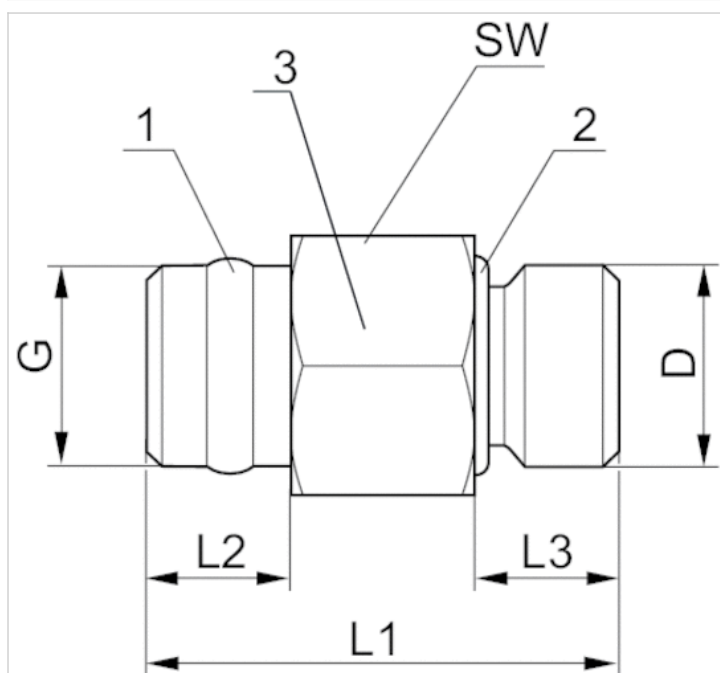

- 1) sealing ring Polytetrafluorethylen
- 2) O-ring - acrylonitrile butadiene rubber
- 3) Housing - brass, nickel-plated

Dimensions

Part No.	Port G	Port D	L1	L2	L3	SW
R412010015	G 1/4	G 1/8	30	10	8.5	17
R412010016	G 1/4	G 1/4	30	10	8.5	17

Blanking screw

- External thread
- G 1/8 G 1/4
- FPT-S-RIO



Working pressure min./max.

0 ... 16 bar

Ambient temperature min./max.

-20 ... 80 °C

Technical data

Part No.	Port G	Delivery unit
1823462004	G 1/8	10 piece
1823462003	G 1/4	10 piece

Technical information

Material

Material	Brass
----------	-------

Dimensions

Dimensions

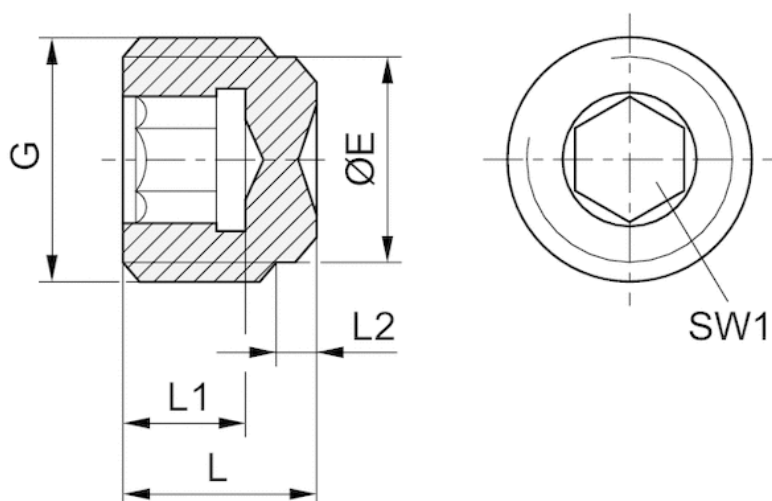

Dimensions in mm

Port G	ØE	L	L1	L2	SW1
G 1/8	8	8	5	2	5
G 1/4	11	11	7	3.5	6

plugs



Technical data

Part No.	Type	Suitable for	Delivery unit
R412010124	plugs	Pressure gauge connection: G 1/4	10 piece

Technical information

Material	
Housing	Polyamide
Seal	Acrylonitrile butadiene rubber

Dimensions

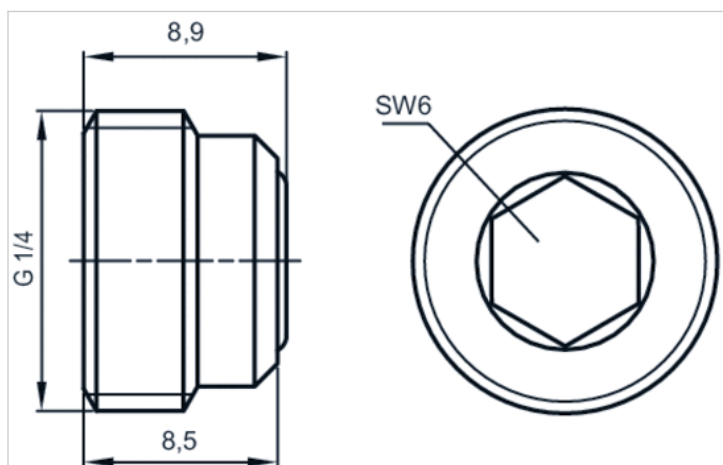

Sealing ring

- Acrylonitrile butadiene styrene



Working pressure min./max.

-0.95 ... 16 bar

Ambient temperature min./max.

-10 ... 60 °C

Technical data

Part No.	Port G	Delivery unit
R412010148	G 3/8	10 piece
R412010149	G 1/2	10 piece
R412010150	G 1	10 piece

For inserting into the O-ring groove when using series QR1 and QR2 fittings.

Technical information

Material	
Material	Acrylonitrile butadiene styrene

Dimensions

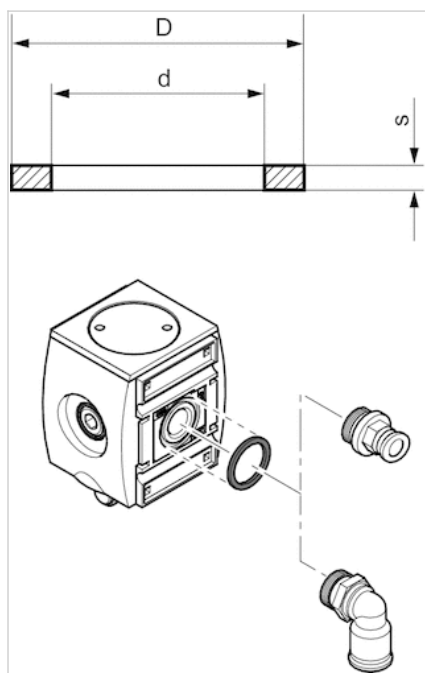

Dimensions

Part No.	usage	Type	d	D	s
R412010148	AS2	For compressed air connection G 3/8	18.5	22.8	2.0
R412010149	AS3	For compressed air connection G 1/2	22.4	26.4	2.0
R412010150	AS5	For compressed air connection G 1	36.9	41.9	2.0

Silencers, series SI1

- G 1/4
- Sintered bronze



Working pressure min./max.	0 ... 10 bar
Ambient temperature min./max.	-25 ... 80 °C
Medium	Compressed air
Sound pressure level	79 dB
Weight	0.02 kg
Comment	Flow characteristic curves can be found under "Diagrams".

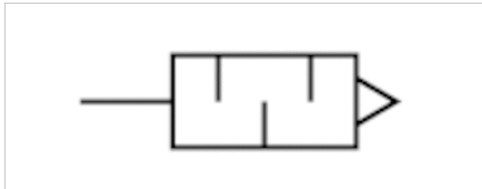

Technical data

Part No.	Compressed air connection	Flow	Delivery unit
		Qn	
1827000001	G 1/4	3390 l/min	10 piece

Weight per piece

Nominal flow Qn at p1 = 6 bar (absolute) freely discharged. Sound pressure level measured at 6 bar against atmosphere at 1 m distance.

Technical information

Material	
Silencer	Sintered bronze
Thread	Brass

Dimensions

Dimensions in mm

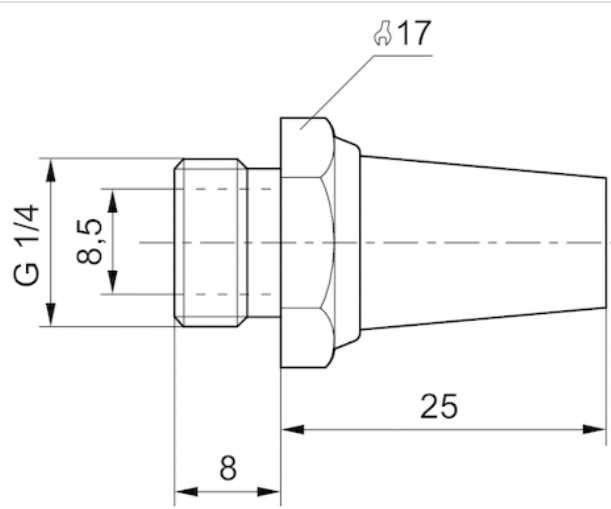

Series RV1

- Qn 1►2 = 676-16037 l/min
- thread-in
- External thread
- G 1/4 G 3/8 G 1/2
- Uncollected



Version
 Certificates
 Working pressure min./max.
 Opening pressure of valve
 Ambient temperature min./max.
 Medium

Poppet valve
 CE declaration of conformity
 0 ... 20 bar
 See table below
 -20 ... 100 °C
 Compressed air

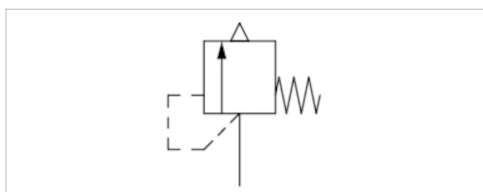

Technical data

Part No.	Port 1	Opening pressure of valve	Flow
			Qn 1►2
R412007521	G 1/4	0.8 bar	676 l/min
R412007522	G 1/4	1.5 bar	996 l/min
R412007523	G 1/4	2 bar	1219 l/min
R412007524	G 1/4	3.5 bar	1872 l/min
R412007525	G 1/4	4 bar	2084 l/min
R412007526	G 1/4	4.8 bar	2424 l/min
R412007527	G 1/4	6 bar	2933 l/min
R412007528	G 1/4	8 bar	3783 l/min
R412007529	G 1/4	10 bar	4632 l/min
R412007530	G 1/4	11 bar	5056 l/min
R412007531	G 1/4	15 bar	6755 l/min
R412007532	G 1/4	16 bar	7179 l/min
R412007533	G 3/8	2 bar	2194 l/min
R412007534	G 3/8	3.7 bar	3567 l/min
R412007535	G 3/8	4 bar	3799 l/min
R412007721	G 3/8	5 bar	4573 l/min
R412007536	G 3/8	6 bar	5347 l/min
R412007537	G 3/8	6.8 bar	5966 l/min
R412007538	G 3/8	8 bar	6895 l/min
R412007539	G 3/8	10 bar	8443 l/min

Part No.	Port 1	Opening pressure of valve	Flow
			Qn 1►2
R412007540	G 3/8	11 bar	9217 l/min
R412007541	G 3/8	16 bar	13087 l/min
R412007542	G 1/2	0.4 bar	1115 l/min
R412007720	G 1/2	2.9 bar	3613 l/min
R412007690	G 1/2	3.5 bar	4182 l/min
R412007691	G 1/2	4 bar	4656 l/min
R412007692	G 1/2	5 bar	5604 l/min
R412007699	G 1/2	5.5 bar	6142 l/min
R412007696	G 1/2	6 bar	6553 l/min
R412007702	G 1/2	6.5 bar	7101 l/min
R412007698	G 1/2	7 bar	7501 l/min
R412007697	G 1/2	8 bar	8449 l/min
R412007693	G 1/2	8.5 bar	9018 l/min
R412007694	G 1/2	9 bar	9398 l/min
R412007700	G 1/2	10 bar	10346 l/min
R412007701	G 1/2	10.5 bar	10934 l/min
R412007695	G 1/2	11 bar	11295 l/min
R412007703	G 1/2	12 bar	12243 l/min
R412007543	G 1/2	16 bar	16037 l/min

Technical information

The specified performance values are achieved at a 10% (PE 1 bar , 0.1 bar) pressure increase, measured with compressed air at 20 °C .

Technical information

Material	
Housing	Brass
Seals	Fluorocaoutchouc

Dimensions

Dimensions

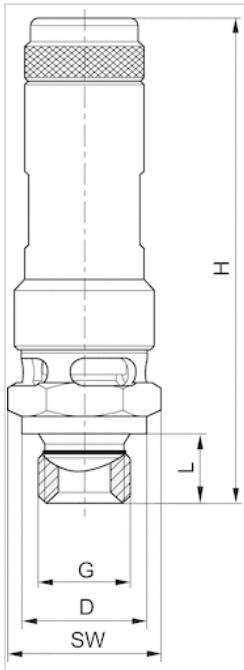

G = connection 1

Dimensions

Part No.	Port G	Ø D	H	L	SW	T [Nm]	NW
R412007521	G 1/4	18	69	10	19	30	8
R412007522	G 1/4	18	69	10	19	30	8
R412007523	G 1/4	18	69	10	19	30	8
R412007524	G 1/4	18	69	10	19	30	8
R412007525	G 1/4	18	69	10	19	30	8
R412007526	G 1/4	18	69	10	19	30	8
R412007527	G 1/4	18	69	10	19	30	8
R412007528	G 1/4	18	69	10	19	30	8
R412007529	G 1/4	18	69	10	19	30	8
R412007530	G 1/4	18	69	10	19	30	8
R412007531	G 1/4	18	69	10	19	30	8
R412007532	G 1/4	18	69	10	19	30	8
R412007533	G 3/8	22	75	10	24	40	10
R412007534	G 3/8	22	75	10	24	40	10
R412007535	G 3/8	22	75	10	24	40	10
R412007721	G 3/8	22	75	10	24	40	10
R412007536	G 3/8	22	75	10	24	40	10
R412007537	G 3/8	22	75	10	24	40	10
R412007538	G 3/8	22	75	10	24	40	10
R412007539	G 3/8	22	88	10	24	40	10
R412007540	G 3/8	22	88	10	24	40	10
R412007541	G 3/8	22	88	10	24	40	10
R412007542	G 1/2	26	78	12	27	50	15

Part No.	Port G	Ø D	H	L	SW	T [Nm]	NW
R412007720	G 1/2	26	78	12	27	50	15
R412007690	G 1/2	26	78	12	27	50	15
R412007691	G 1/2	26	78	12	27	50	15
R412007692	G 1/2	26	78	12	27	50	15
R412007699	G 1/2	26	78	12	27	50	15
R412007696	G 1/2	26	78	12	27	50	15
R412007702	G 1/2	26	78	12	27	50	15
R412007698	G 1/2	26	78	12	27	50	15
R412007697	G 1/2	26	77.5	12	27	50	15
R412007693	G 1/2	26	91	12	27	50	15
R412007694	G 1/2	26	91	12	27	50	15
R412007700	G 1/2	26	91	12	27	50	15
R412007701	G 1/2	26	91	12	27	50	15
R412007695	G 1/2	26	91	12	27	50	15
R412007703	G 1/2	26	91	12	27	50	15
R412007543	G 1/2	26	91	12	27	50	15

T = maximum torque

NW = nominal width

Round plug connector, Series CON-RD

- Socket M12x1 5-pin A-coded angled 90°
- open cable ends
- with cable
- shielded



Ambient temperature min./max.	-25 ... 80 °C
Operational voltage	48 V AC/DC
Protection class	IP67
Wire cross-section	0.34 mm ²
Weight	See table below

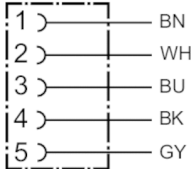

Technical data

Part No.	Max. current	Number of wires	Cable-Ø	Cable length	Weight
R419800109	4 A	5	6 mm	2.5 m	0.145 kg
R419800110	4 A	5	6 mm	5 m	0.27 kg
R419800546	4 A	5	6 mm	10 m	0.514 kg

Technical information

Material	
Housing	Thermoplastic elastomer
Cable sheath	Polyurethane

Dimensions

Dimensions

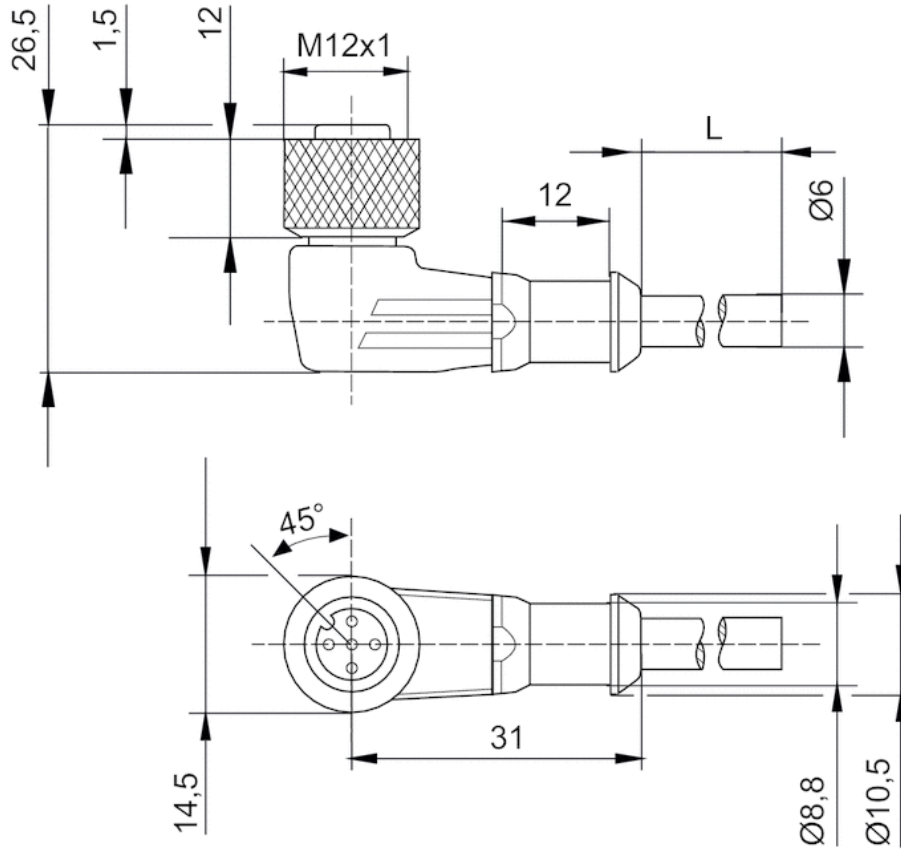

L = length

Pin assignments

Pin assignment, socket

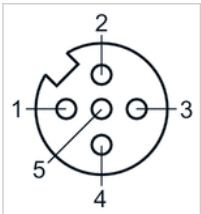

- (1) BN=brown
- (2) WH=white
- (3) BU=blue
- (4) BK=black
- (5) GY=grey

Round plug connectors with cable, Series CON-RD

- Plug M12x1 8-pin X-coded angled 90°
- Plug RJ45 8-pin X-coded straight
- shielded



Ambient temperature min./max.	-25 ... 85 °C
Protection class	IP66K
Wire cross-section	0.14 mm ²

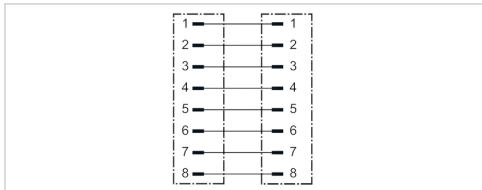

Technical data

Part No.	Max. current	Cable length
R412027647	0.5 A	5 m

Technical information

Material	
Cable sheath	Polyurethane

Dimensions

Dimensions

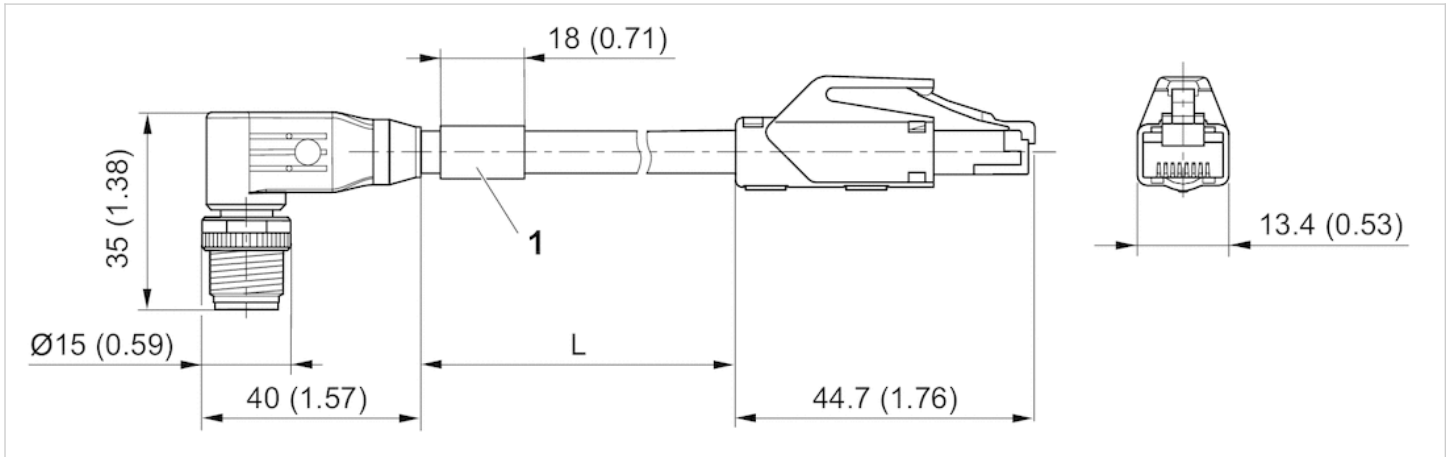

1) Name plate

Pin assignments

Plug pin assignment

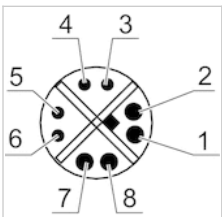

Plug pin assignment

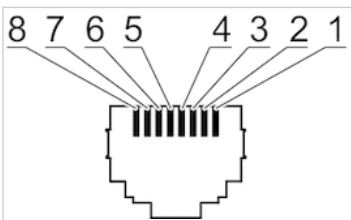

Efficient pneumatic solutions, our program: cylinders and drives, valves and valve systems, air supply management

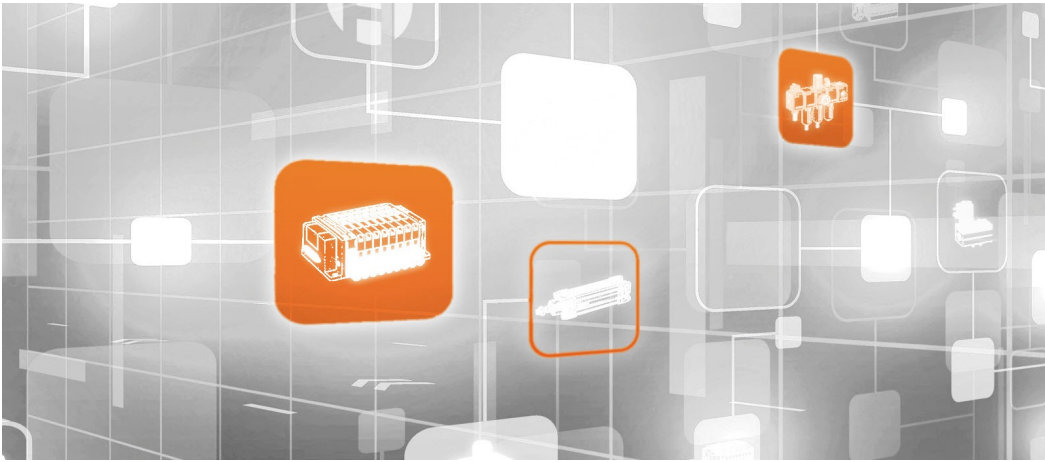

Visit us: [Emerson.com/Aventics](https://www.emerson.com/aventics)

Your local contact: [Emerson.com/contactus](https://www.emerson.com/contactus)



[Emerson.com](https://www.emerson.com)



[Facebook.com/EmersonAutomationSolutions](https://www.facebook.com/EmersonAutomationSolutions)



[LinkedIn.com/company/Emerson-Automation-Solutions](https://www.linkedin.com/company/Emerson-Automation-Solutions)



[Twitter.com/EMR_Automation](https://twitter.com/EMR_Automation)

An example configuration is depicted on the title page. The delivered product may thus vary from that in the illustration. Subject to change. This Document, as well as the data, specifications and other information set forth in it, are the exclusive property of AVENTICS GmbH. It may not be reproduced or given to third parties without its consent. Only use the AVENTICS products shown in industrial applications. Read the product documentation completely and carefully before using the product. Observe the applicable regulations and laws of the respective country. When integrating the product into applications, note the system manufacturer's specifications for safe use of the product. The data specified only serve to describe the product. No statements concerning a certain condition or suitability for a certain application can be derived from our information. The information given does not release the user from the obligation of own judgment and verification. It must be remembered that the products are subject to a natural process of wear and aging.

The Emerson logo is a trademark and service mark of Emerson Electric Co. Brand logotype are registered trademarks of one of the Emerson family of companies. All other marks are the property of their respective owners. © 2017 Emerson Electric Co. All rights reserved.
2019-03



CONSIDER IT SOLVED™