

## Series RDC



AVENTICS™ Series RDC



# Diaphragm and piston actuators, Series RDC

- Ø 52.5-115 mm
- Ports G 1/8 G 3/8 G 1/4
- Single-acting, retracted without pressure
- Piston rod External thread

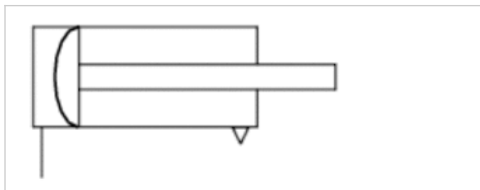

Compressed air connection	Internal thread
Ambient temperature min./max.	-25 ... 80 °C
Medium temperature min./max.	-25 ... 80 °C
Medium	Compressed air
Max. particle size	5 µm
Oil content of compressed air	0 ... 1 mg/m <sup>3</sup>
Pressure for determining piston forces	6.3 bar
Weight	See table below

## Technical data

Piston Ø Piston rod thread Ports Piston rod Ø	52.5 mm M10x1,25 G 1/8 12 mm	75 mm M10x1,25 G 3/8 16 mm	85 mm M16x1,5 G 1/4 20 mm	95 mm M16x1,5 G 3/8 20 mm	115 mm M16x1,5 G 3/8 20 mm
Stroke 40	5218535110	-	-	-	-
60	-	5218555110	-	-	-
70	-	-	5218565110	-	-
75	-	-	-	5218575120	-
95	-	-	-	-	5218585120

## Technical data

Piston Ø	52.5 mm	75 mm	85 mm	95 mm
Extracting piston force	1363 N	2783 N	3575 N	4465 N
Weight 0 mm stroke	1.6 kg	3 kg	3.6 kg	4.1 kg
Working pressure min./max.	0.03 ... 8 bar	0.03 ... 8 bar	0.035 ... 8 bar	0.035 ... 8 bar
Stroke max.	40 mm	60 mm	70 mm	75 mm

Piston Ø	115 mm
Extracting piston force	6543 N

Piston Ø	115 mm
Weight 0 mm stroke	5.8 kg
Working pressure min./max.	0.035 ... 8 bar
Stroke max.	95 mm

## Technical information

The pressure dew point must be at least 15 °C under ambient and medium temperature and may not exceed 3 °C .  
 The oil content of compressed air must remain constant during the life cycle.  
 Use only the approved oils from AVENTICS. Further information can be found in the “Technical information” document (available in the MediaCentre).

## Technical information

Material	
Cylinder tube	Steel
Piston rod	Stainless steel
Piston	Aluminum
Front cover	Aluminum, chrome-plated
End cover	Aluminum, chrome-plated
Seal	Acrylonitrile butadiene rubber
Nut for piston rod	Steel, galvanized

## Dimensions

### Dimensions

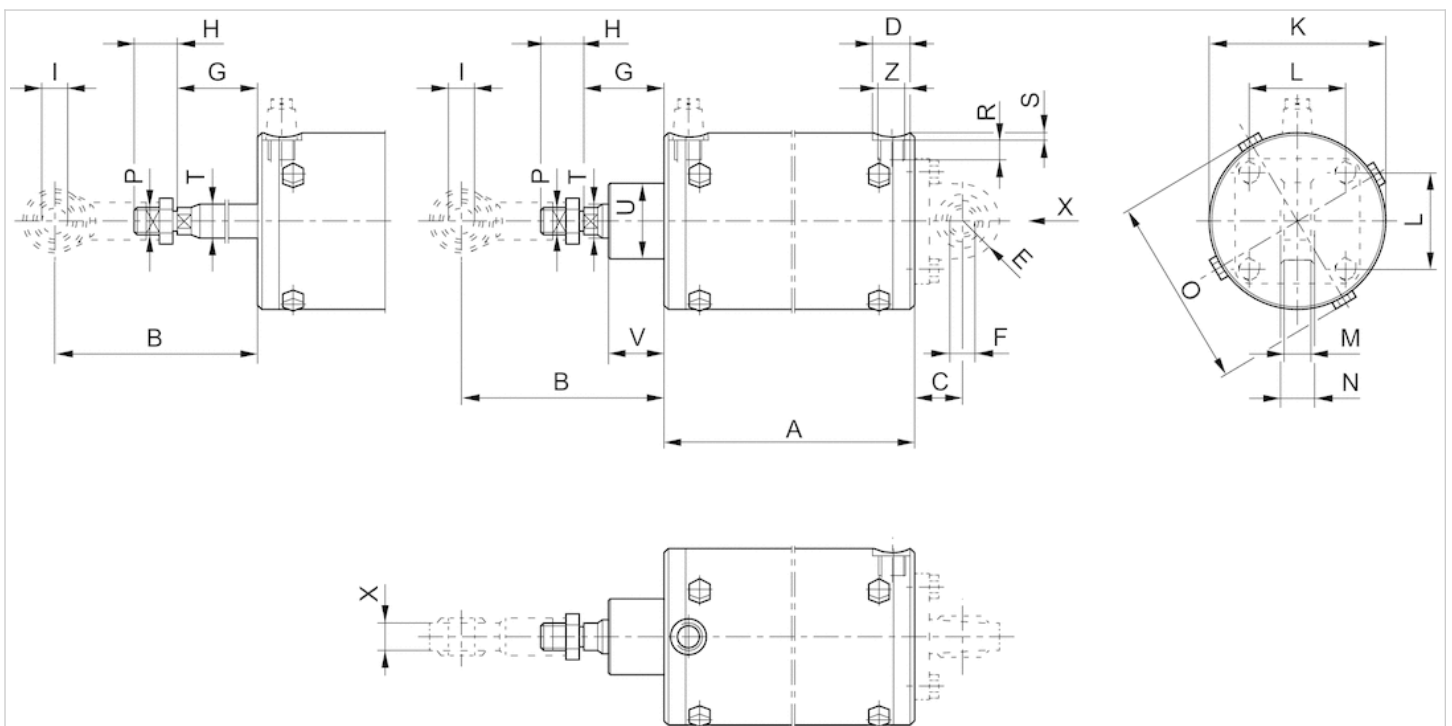

## Dimensions

Piston Ø	A	B	C	D	E	F H7	G	H	I H7	K	L	M	N	O	P	R	S	U	V
52.5 mm	140	67	29	17	15	10	19	26	10	60	33	7-9	14	68	M10x1,25	8	3.1	-	-
75 mm	166	84	26	23	18	12	32	31	10	86	49	9-11	16	92	M10x1,25	12	3.5	-	-
85 mm	202	118	30	22	22	16	43	26	16	97	59	14,5-17,5	21	108	M16x1,5	12	4.5	-	-
95 mm	208	124	30	23	22	16	49	26	16	106	59	14,5-17,5	21	117	M16x1,5	12	3.5	45	34
115 mm	247	120	38	23	25	16	45	26	16	127	75	14-17,5	21	138	M16x1,5	12	3.6	45	33

Piston Ø	T h7	X	Z
52.5 mm	12	14	G 1/8
75 mm	16	14	G 3/8
85 mm	20	21	G 1/4
95 mm	20	21	G 3/8
115 mm	20	21	G 3/8

## Diagrams

### Force-stroke characteristic curve, 0.1 bar

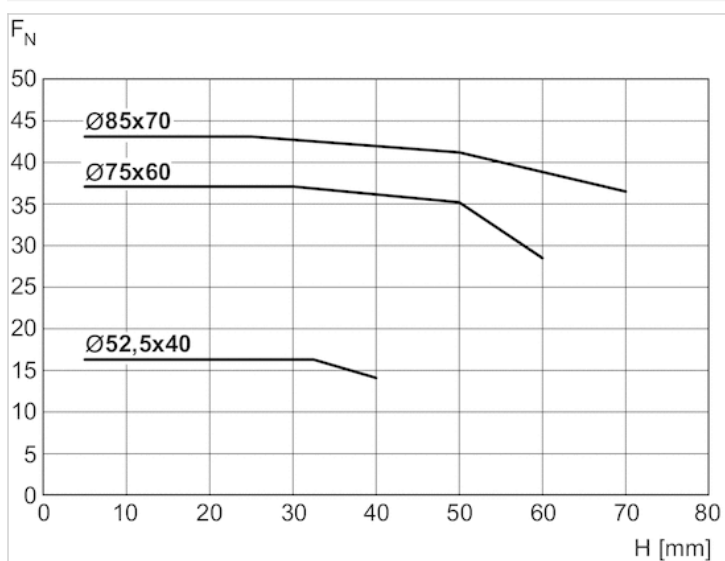

FN= extending piston force

H = stroke

Force-stroke characteristic curve, 0.3 bar

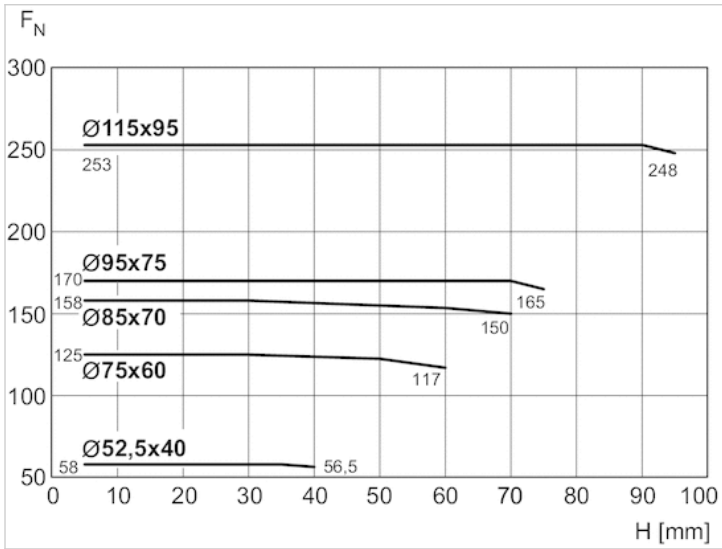

FN= extending piston force

H = stroke

Force-stroke characteristic curve, 0.5 bar

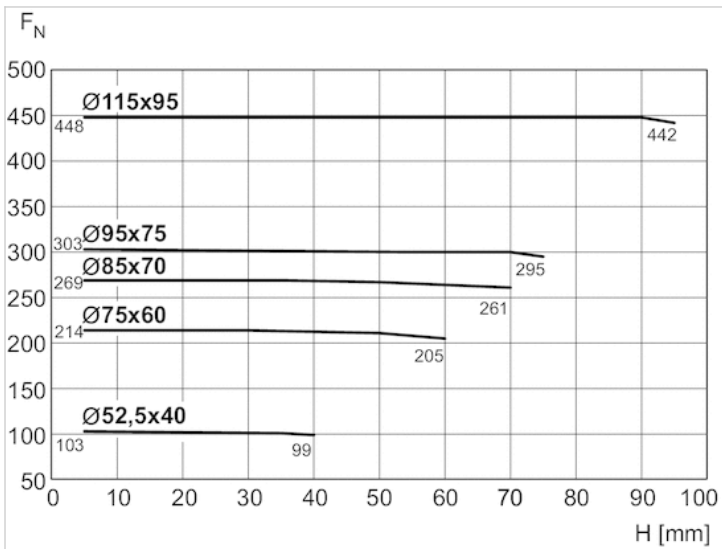

FN= extending piston force

H = stroke

Force-stroke characteristic curve, 4 bar

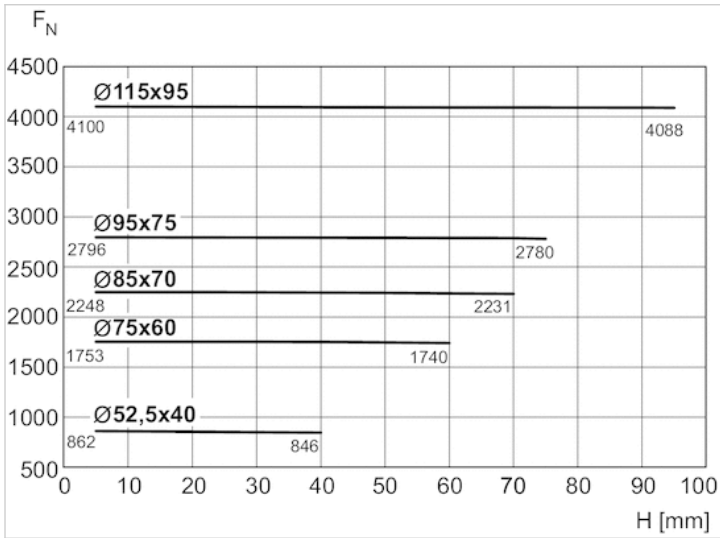

FN= extending piston force  
H = stroke

Force-stroke characteristic curve, 6 bar

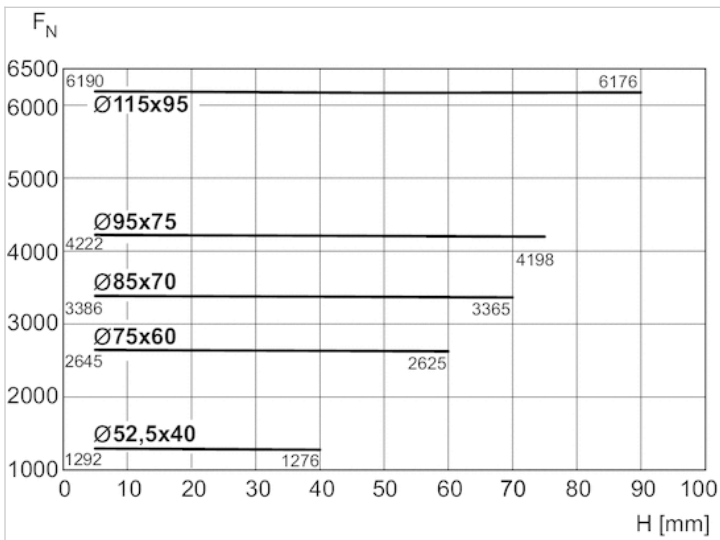

FN= extending piston force  
H = stroke

Force-stroke characteristic curve, 8 bar

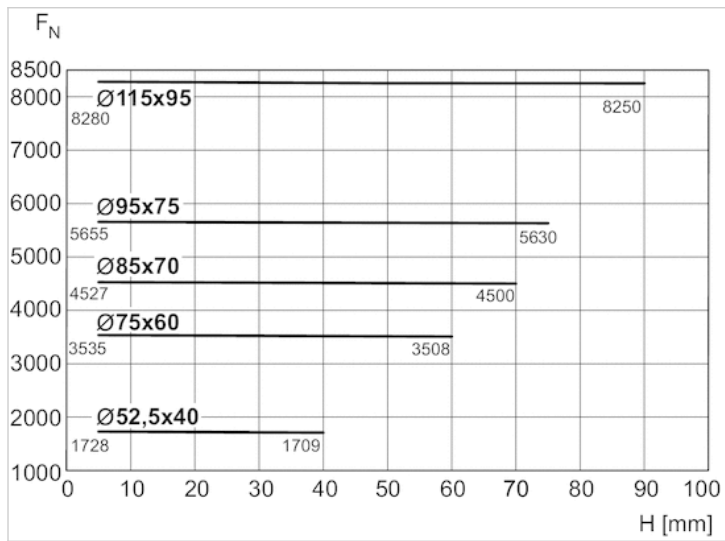

FN= extending piston force  
 H = stroke

# Rear eye MP6, Series CM1

- With ball joint and foot

- Suitable piston Ø 52.5 75 85, 95 115 mm



Weight

See table below

## Technical data

Part No.	Piston Ø	Swivel bearing Ø	Bearing material, inner ring	Bearing material, outer ring	Weight
5220163442	52.5 mm	10 mm	Stainless steel	Brass with PTFE coating	0.2 kg
5220363442	75 mm	12 mm	Stainless steel	Brass with PTFE coating	0.4 kg
5220463442	85, 95 mm	16 mm	Stainless steel	Brass with PTFE coating	0.6 kg
5220563442	115 mm	16 mm	Stainless steel	Brass with PTFE coating	1.1 kg

Scope of delivery: clevis incl. mounting screws

## Technical information

Material	
Material	Aluminum
Screws	galvanized steel



## Dimensions

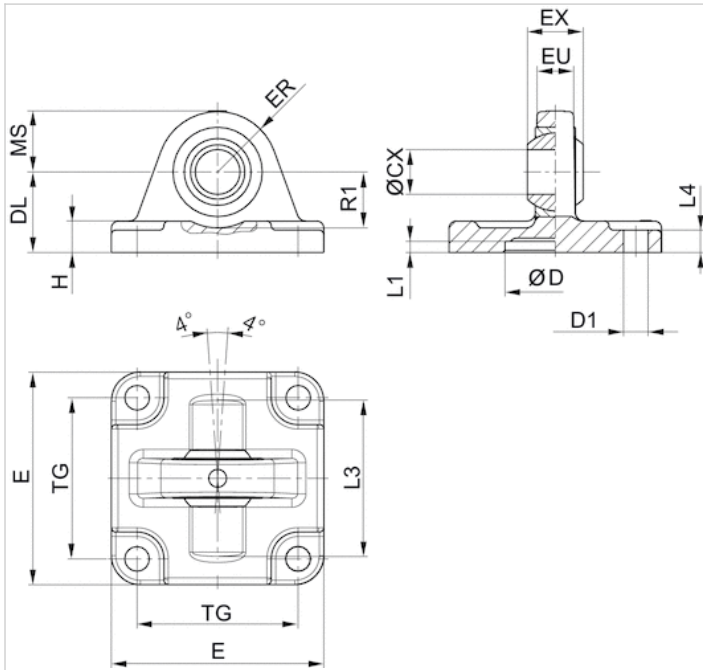

## Dimensions

Part No.	Piston Ø	ØCX H7	ØD H11	ØD1 H13	DL ±0,2	E	EX -0,1	ER	EU	H	L1 min.	L3
5220163442	52.5 mm	10	-	7.5	29	45	14	15	10.5	8	-	-
5220363442	75 mm	12	-	10	26	65	16	18	12	10	-	-
5220463442	85, 95 mm	16	-	10	30	75	21	22	15	10	-	-
5220563442	115 mm	16	-	12	37.5	95	21	25	15	12	-	-

L4	MS -0,5	R1 min.	TG
-	-	-	33
-	-	-	49
-	-	-	59
-	-	-	75

# Piston rod nut MR9



Weight

See table below

## Technical data

Part No.	Suitable piston rod thread	Weight
1823A00020	M10x1,25	0.01 kg
1823300030	M16x1,5	0.017 kg

## Technical information

Material	
	Steel
	galvanized

## Dimensions

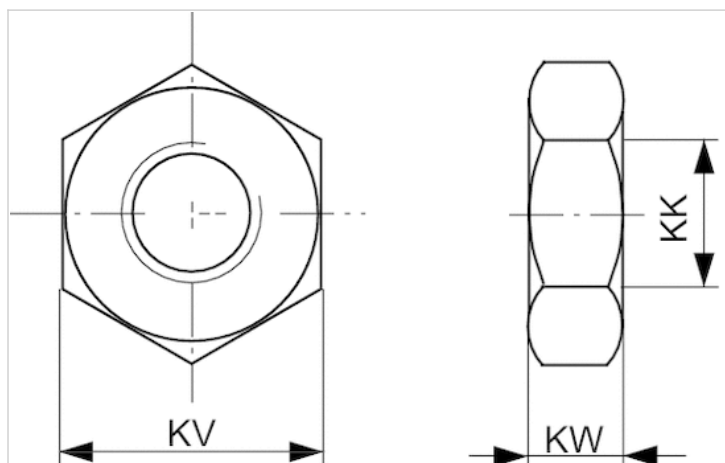

## Dimensions

Part No.	KK	KV	KW
1823300030	M16x1,5	24	8

# Rod clevis AP2, Series CM2

- to mount on cylinder PRA, TRB, CCI, MNI, ICM, KPZ, KHZ, 167, CVI, RPC, RDC, ITS



Weight

See table below

## Technical data

Part No.	Suitable piston rod thread	for	Weight
1822122024	M10x1,25	PRA TRB CCI MNI ICM KPZ 167 CVI RPC RDC	0.1 kg
1822122005	M16x1,5	PRA TRB CCI KPZ 167 CVI RPC RDC 102	0.4 kg

Part No.	Fig.
1822122024	Fig. 1
1822122005	Fig. 1

## Technical information

Material
Steel
galvanized

## Dimensions

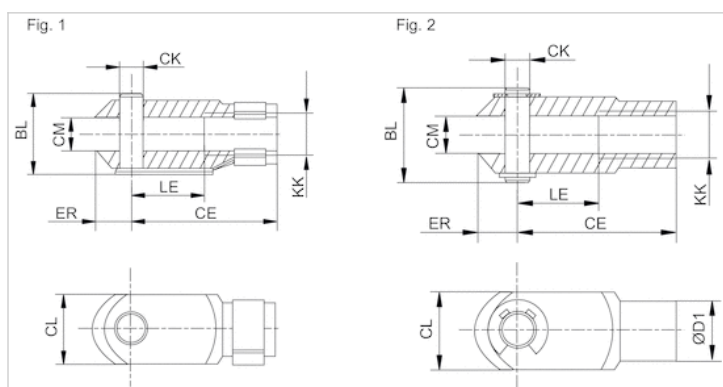

## Dimensions

Part No.	KK	BL	CE	ØCK e11	CL	CM	ØD1	ER	LE	Fig.
1822122024	M10x1,25	26	40	10	20	10	18	12	20	Fig. 1
1822122005	M16x1,5	39	64	16	32	16	26	19	32	Fig. 1

# Rod clevis PM6, Series CM2

- for ball eye rod end AP6



## Technical data

Part No.	for	Swivel bearing Ø
1822122032	AP6	14 mm
1822122034	AP6	21 mm

Scope of delivery incl. bolt

## Technical information

Material	
	Steel
	galvanized

## Dimensions

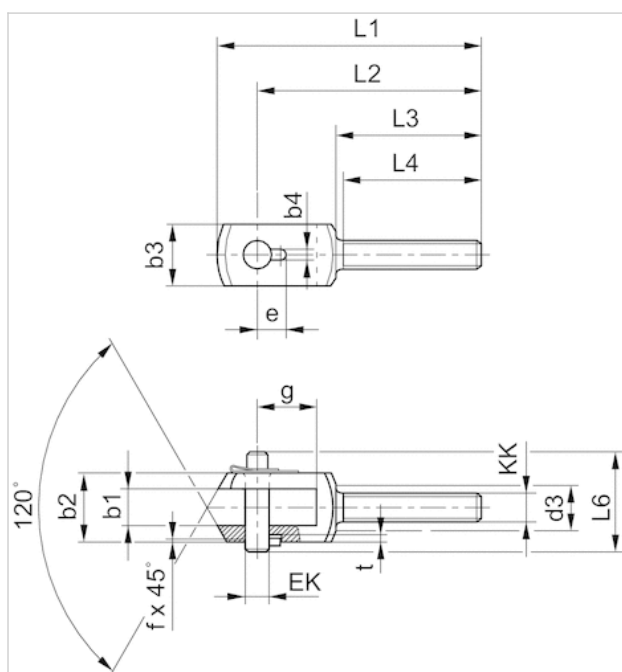

## Dimensions

Part No.	b1 B12	b2 d12	b3	b4 +0,2	d3	e +0,3	EK	f	g	L1	L2	L3	L4 +1	L6	t +0,2
1822122032	14	28	20	3.3	17	11.5	10	0.7	20	90	78	53	50	35	3
1822122034	21	40	35	4.3	24	14	16	1	31	129	108	65	62	50	3

# Ball eye rod end AP6, series CM2

- with flange to mount on cylinder PRA, TRB, CCI, SSI, MNI, RPC, KPZ, 167, CVI, RDC, 102, ITS



Weight

See table below

## Technical data

Part No.	Suitable piston rod thread	for	Swivel bearing Ø
1822124003	M10x1,25	PRA TRB MNI CCI SSI RPC KPZ 167 CVI RDC	254 mm
1822124005	M16x1,5	PRA TRB CCI SSI RPC KPZ 167 CVI RDC 102	406.4 mm

Part No.	Weight
1822124003	0.07 kg
1822124005	0.21 kg

## Technical information

Material	
	Steel
	galvanized



## Dimensions

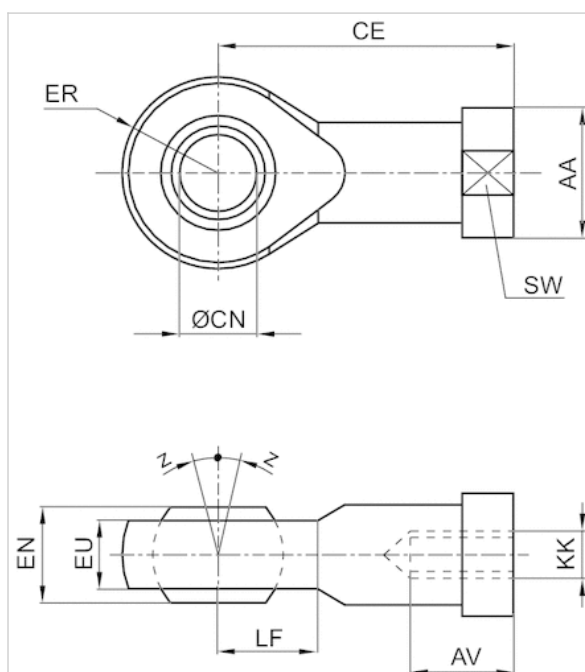

## Dimensions

Part No.	KK	AA	AV min.	CE	Ø CN H7	EN -0,1	ER	EU max.	LF	SW	Z [°] max.
1822124003	M10x1,25	19	15	43	10	14	14	11.5	14	17	4
1822124005	M16x1,5	27	24	64	16	21	21	15.5	21	22	4

# Compensating coupling PM5, series CM2

- to mount on cylinder PRA, TRB, CCL-IS/-IC, CCI, SSI, MNI, KPZ, KHZ, 167, CVI, RPC, RDC, ITS■spherical



Weight

See table below

## Technical data

Part No.	Suitable piston rod thread	for
R412026142	M10x1,25	PRA TRB CCL-IS CCL-IC CCI SSI KPZ 167 CVI RPC
R412026144	M16x1,5	PRA TRB CCI CCL-IS CCL-IC KPZ 167 CVI RPC RDC

Part No.	Weight
R412026142	0.21 kg
R412026144	0.65 kg

## Technical information

Material
Steel
galvanized

## Dimensions

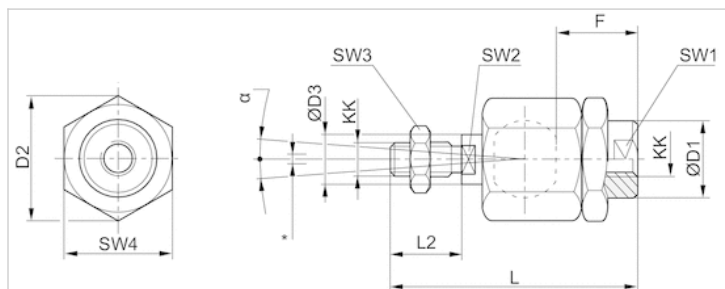

\* Radial joint

## Dimensions

Part No.	KK	$\varnothing D1$	$D2$	$\varnothing D3$	F	$L \pm 2$	L2	SW1	SW2	SW3	SW4	$\alpha$ [°]	1)	2)
R412026142	M10x1,25	22	32	14	23	74.5	23	19	12	17	30	8	0.05-0.5	0-2
R412026144	M16x1,5	32	45	22	30	103	30	30	20	24	41	6	0.05-0.5	0-2

1) Axial play

2) Radial play

# Compensating coupling PM7, series CM2

- to mount on cylinder PRA, TRB, CCL-IS/-IC, CCI, SSI, KPZ, 167, CVI, RPC, ITS with plate



Weight

See table below

## Technical data

Part No.	Suitable piston rod thread	for	Weight
1827001629	M10x1,25	PRA TRB CCL-IS CCL-IC CCI SSI KPZ RPC 167	0.3 kg
1827001631	M16x1,5	PRA TRB CCL-IS CCL-IC CCI SSI KPZ RPC 167	0.9 kg

## Technical information

Material	
	Steel
	galvanized

## Dimensions

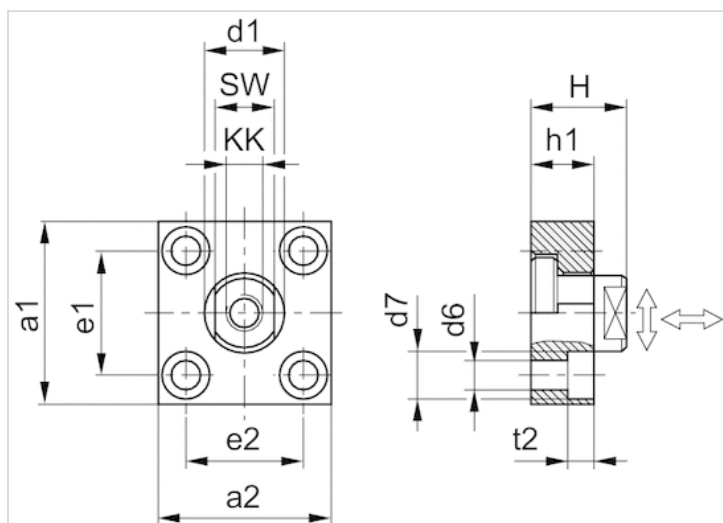

## Dimensions

Part No.	a1	a2	d1 h11	d6 H13	d7 H13	e1 H13	e2	h1	t2	H	SW
1827001629	60	37	20	6.6	11	36 ±0,15	23 ±0,15	15	7	24	17
1827001631	80	80	30	11	18	58 ±0,2	58 ±0,2	20	11	32	24

Tightening torque for the coupling pin $M_a \pm 5\%$	Axial play min./max.	Radial play min./max.
17 Nm	0.4 0.8 mm	1.9 2.3 mm
71 Nm	0.4 0.8 mm	1.9 2.3 mm

# Silencers, series SI1

- G 1/8
- Sintered bronze



Working pressure min./max.	0 ... 10 bar
Ambient temperature min./max.	-25 ... 80 °C
Medium	Compressed air
Sound pressure level	75 dB
Weight	0.01 kg
Comment	Flow characteristic curves can be found under "Diagrams".

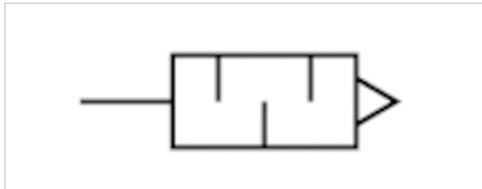

## Technical data

Part No.	Compressed air connection	Flow	Delivery unit
		Qn	
1827000000	G 1/8	1623 l/min	10 piece

Weight per piece

Nominal flow Qn at p1 = 6 bar (absolute) freely discharged. Sound pressure level measured at 6 bar against atmosphere at 1 m distance.

## Technical information

Material	
Silencer	Sintered bronze
Thread	Brass

## Dimensions

### Dimensions in mm

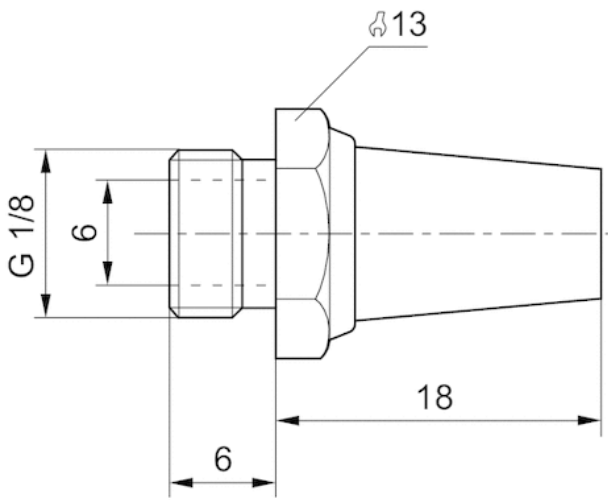

## Diagrams

### Flow diagram, 1827000000

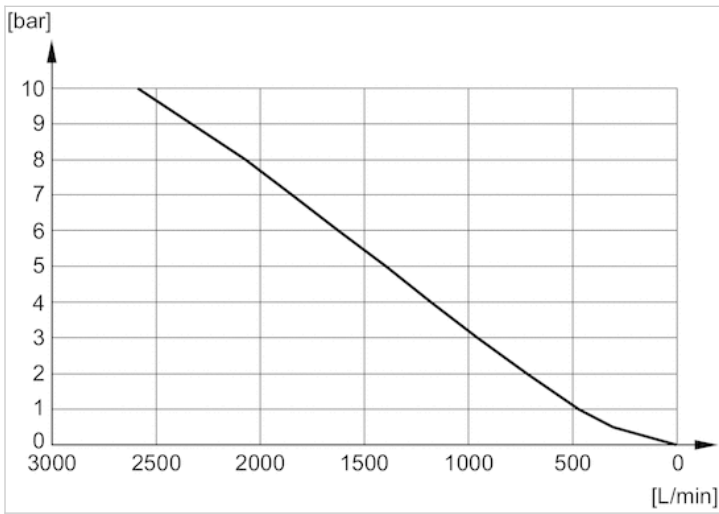

# Silencers, series SI1

- G 1/4
- Sintered bronze



Working pressure min./max.	0 ... 10 bar
Ambient temperature min./max.	-25 ... 80 °C
Medium	Compressed air
Sound pressure level	See table below
Weight	See table below
Comment	Flow characteristic curves can be found under "Diagrams".

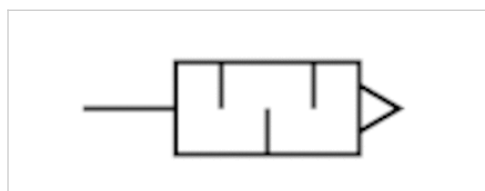

## Technical data

Part No.	Compressed air connection	Sound pressure level	Flow	Delivery unit	Weight
			Qn		
R412004817	G 1/4	-	5950 l/min	10 piece	0.013 kg
1827000001	G 1/4	79 dB	3390 l/min	10 piece	0.02 kg

### Weight per piece

Nominal flow Qn at p1 = 6 bar (absolute) freely discharged. Sound pressure level measured at 6 bar against atmosphere at 1 m distance.

## Technical information

Material	
Silencer	Sintered bronze
Thread	Brass



## Dimensions

### Dimensions in mm

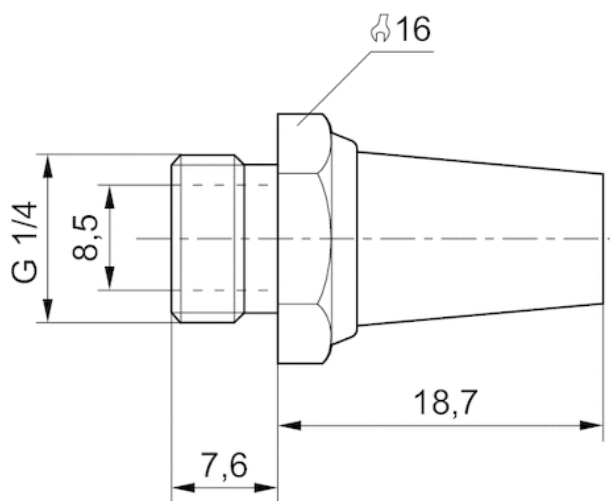

### Dimensions in mm

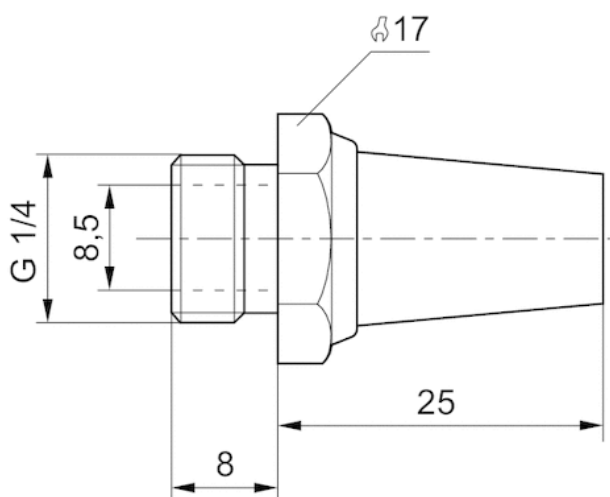

# Silencers, series SI1

- G 3/8
- Sintered bronze



Working pressure min./max.	0 ... 10 bar
Ambient temperature min./max.	-25 ... 80 °C
Medium	Compressed air
Sound pressure level	84 dB
Weight	0.05 kg
Comment	Flow characteristic curves can be found under "Diagrams".

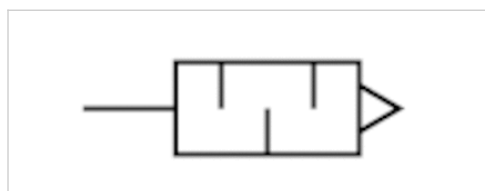

## Technical data

Part No.	Compressed air connection	Flow	Delivery unit
		Qn	
1827000002	G 3/8	6554 l/min	5 piece

Weight per piece

Nominal flow Qn at p1 = 6 bar (absolute) freely discharged. Sound pressure level measured at 6 bar against atmosphere at 1 m distance.

## Technical information

Material	
Silencer	Sintered bronze
Thread	Brass

## Dimensions

### Dimensions in mm

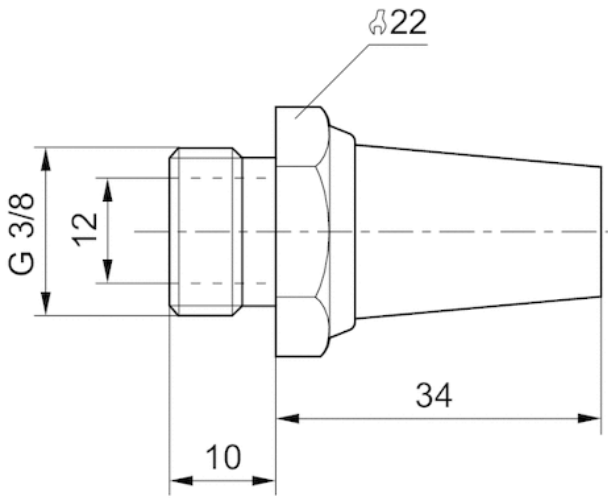

## Diagrams

### Flow diagram, 1827000002

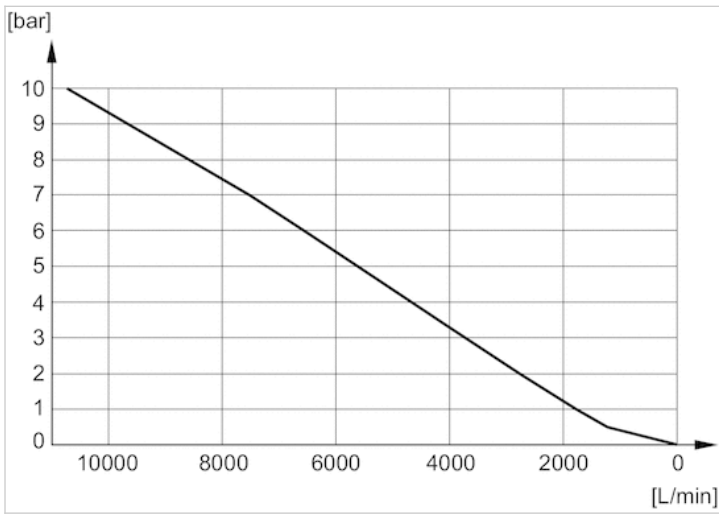

# Efficient pneumatic solutions, our program: cylinders and drives, valves and valve systems, air supply management



Visit us: [Emerson.com/Aventics](https://www.emerson.com/Aventics)

Your local contact: [Emerson.com/contactus](https://www.emerson.com/contactus)



Emerson.com



[Facebook.com/EmersonAutomationSolutions](https://www.facebook.com/EmersonAutomationSolutions)



[LinkedIn.com/company/Emerson-Automation-Solutions](https://www.linkedin.com/company/Emerson-Automation-Solutions)



[Twitter.com/EMR\\_Automation](https://twitter.com/EMR_Automation)

An example configuration is depicted on the title page. The delivered product may thus vary from that in the illustration. Subject to change. This Document, as well as the data, specifications and other information set forth in it, are the exclusive property of AVENTICS GmbH. It may not be reproduced or given to third parties without its consent. Only use the AVENTICS products shown in industrial applications. Read the product documentation completely and carefully before using the product. Observe the applicable regulations and laws of the respective country. When integrating the product into applications, note the system manufacturer's specifications for safe use of the product. The data specified only serve to describe the product. No statements concerning a certain condition or suitability for a certain application can be derived from our information. The information given does not release the user from the obligation of own judgment and verification. It must be remembered that the products are subject to a natural process of wear and aging.

The Emerson logo is a trademark and service mark of Emerson Electric Co. Brand logotype are registered trademarks of one of the Emerson family of companies. All other marks are the property of their respective owners. © 2017 Emerson Electric Co. All rights reserved.  
2019-03



**CONSIDER IT SOLVED™**